This is an electronic reprint of the original article.
This reprint may differ from the original in pagination and typographic detail.

Halme, Aarne; Selkänaho, Jorma; Noponen, Tuula; Kohonen, Axel

An alternative concept for DMFC - Combined electrolyzer and H2 PEMFC

Published in:
International Journal of Hydrogen Energy

DOI:
[10.1016/j.ijhydene.2015.12.007](https://doi.org/10.1016/j.ijhydene.2015.12.007)

Published: 30/01/2016

Document Version
Publisher's PDF, also known as Version of record

Please cite the original version:
Halme, A., Selkänaho, J., Noponen, T., & Kohonen, A. (2016). An alternative concept for DMFC - Combined electrolyzer and H2 PEMFC. International Journal of Hydrogen Energy, 41(4), 2154-2164. DOI: 10.1016/j.ijhydene.2015.12.007

This material is protected by copyright and other intellectual property rights, and duplication or sale of all or part of any of the repository collections is not permitted, except that material may be duplicated by you for your research use or educational purposes in electronic or print form. You must obtain permission for any other use. Electronic or print copies may not be offered, whether for sale or otherwise to anyone who is not an authorised user.

Available online at www.sciencedirect.com

ScienceDirect

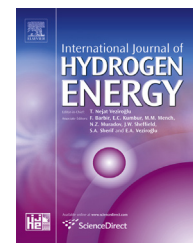
journal homepage: www.elsevier.com/locate/hydro

An alternative concept for DMFC – Combined electrolyzer and H₂ PEMFC

Aarne Halme^{a,*}, Jorma Selkäinen^a, Tuula Noponen^b, Axel Kohonen^a

^a Aalto University, Department of Electrical Engineering and Automation, Finland

^b Aalto University, Department of Energy Technology, Finland

ARTICLE INFO

Article history:

Received 30 May 2015

Received in revised form

24 November 2015

Accepted 4 December 2015

Available online 6 January 2016

Keywords:

Methanol electrolysis

Combined electrolysis and PEM fuel cell

Hydrogen as energy carrier

Portable power sources

ABSTRACT

The article introduces a novel concept that combines a methanol electrolyzer and a H₂-PEMFC to a power source for small scale applications, e.g. portable electronics. Due to the low energy requirements of methanol electrolysis the released hydrogen contains enough energy both to maintain the electrolysis and to provide power to the application device. The concept is comparable to DMFC technology, but offers additional features, which make it interesting when developing the methanol based small scaled power sources further. The article considers those features both theoretically and experimentally by a proof-of-concept approach. Comparison to DMFC is made through a semi-empirical modeling which determines the conditions where the combined system has a better power efficiency. In addition, some interesting properties like tolerance to high methanol concentrations are considered and justified. Finally, a rough comparison of the stack sizes needed by the two concepts is made through an illustrative design example.

Copyright © 2015, The Authors. Published by Elsevier Ltd on behalf of Hydrogen Energy Publications, LLC. This is an open access article under the CC BY-NC-ND license (<http://creativecommons.org/licenses/by-nc-nd/4.0/>).

Introduction

For a long time direct methanol fuel cells (DMFCs) have been the main concept when developing low temperature power sources for portable electronic and other low power devices. Although good progress has been seen during the last years, there still exist problems like relatively low power density compared to H₂ PEMFCs, and catalyst poisoning when using high methanol concentration. Auto-reforming of methanol at high temperatures (200–400 °C) is possible [1–3], but using such technology is not feasible in most of the mentioned applications because of human safety. A recent review of this technology can be found in Ref. [21]. Aqueous methanol can also be reformed at low temperatures of 20–50 °C by

electrolysis [4–12] using a very small amount of energy, in practice 0.7–1.0 Wh/LH₂ only, the theoretical value being even lower. The lower value corresponds to 0.31 V cell voltage and the higher one to 0.45 V cell voltage in a high efficiency electrolyzer, where most of electrons in its current transfer to hydrogen output. In such electrolyzers the hydrogen production and methanol consumption are directly related to the current taken by the device: 0.45 LH₂/Ah and 0.25 mL MeOH/Ah. These values, which are calculated from the electron balance when methanol is spitted to hydrogen and carbon dioxide (here in 293,2 K temperature and 101,3 kPa pressure), are independent on the energy used, so the critical issue for low energy production of hydrogen is to make the electrolysis cell voltage low. As will be seen later on, low enough cell voltages can be obtained in certain conditions. This opens up

* Corresponding author. Tel.: +358 50 5553390.

E-mail address: aarne.halme@aalto.fi (A. Halme).

<http://dx.doi.org/10.1016/j.ijhydene.2015.12.007>

0360-3199/Copyright © 2015, The Authors. Published by Elsevier Ltd on behalf of Hydrogen Energy Publications, LLC. This is an open access article under the CC BY-NC-ND license (<http://creativecommons.org/licenses/by-nc-nd/4.0/>).

interesting possibilities to develop low temperature applications for methanol auto-reforming in connection with fuel cells. Because the combination then serves about the same purpose as the Direct Methanol Fuel Cell (DMFC), it is natural to ask its relation to this technology.

Here and in what follows electrolysis means Pt catalyzed electrolysis, which uses a PEM membrane between the electrodes and standard type grooved flow fields. Recent studies indicate that the energy efficiency of such electrolyzers can be further improved by improving the mass transfer properties at cathode using porous metal flow fields [19]. The same technology can be also used to improve a PEM fuel cell performance [20]. There are also studies of electrolysis with alkaline membrane cells [13], but they have not shown good enough performance so far and are not considered here further. Incorporation of a reformer unit and a fuel cell is a well-known process, for example a high temperature internal reforming alcohol fuel cell has been studied in Ref. [14], but there are no studies where a low temperature methanol electrolysis unit is incorporated into hydrogen fuel cell system. Because the calorific value of hydrogen (HHV) is around 3.5 Wh/LH₂ and a PEMFC can convert around 50% of it to electrical energy, a few interesting questions emerge. Is it possible to utilize an electrolyzer as the reformer in such a way that the energy required by the electrolyzer is provided by the PEMFC, which converts the hydrogen to electricity, so that there still is net energy left for the application device? If so, what is the performance of this concept compared to the one of DMFCs? What advantages does it possibly give? This paper shows that the concept is possible and answers the questions by a theoretical and experimental basis.

The concept

Electrolyzer combined with a fuel cell

The concept discussed further in this article is illustrated in Fig. 1. MeOH-water solution is circulated between the storage tank and the anode of the electrolyzer (EL), where hydrogen is formed in its cathode. The electrolyzer has a DMFC type MEA. Only methanol is decomposed because a low voltage of 350–450 mV is applied to the electrodes. The voltage and current are taken through a controllable DC/DC converter from the

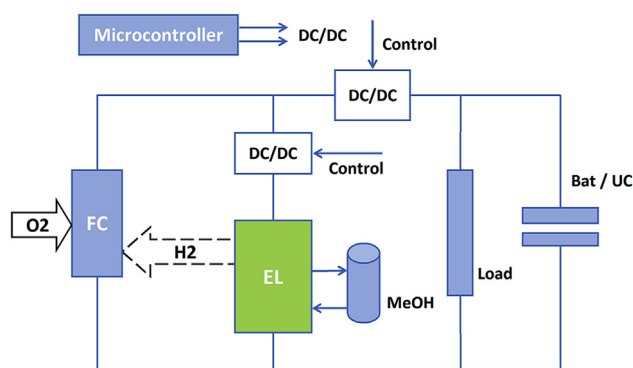

Fig. 1 – Operating principle of the electrolyzer-fuel cell system.

PEM fuel cell to which hydrogen is fed from the electrolyzer. The role of the controllable DC/DC- converter is to provide a suitable voltage level for the electrolyzer and maintain the current needed for hydrogen production in different operation conditions. The electrical load is connected parallel to the electrolyzer through a (optional) DC/DC-converter. The system needs also an electrical intermediate storage (an ultra-capacitor or battery) for starting the operation and to smooth out power variations from the load. In addition, the system needs a relatively simple controller (not considered further in this article) to maintain the optimum balance between the hydrogen production and the load demand in such a way that maximum load efficiency can be obtained.

The system in Fig. 1 operates autonomously and it has an efficiency of converting methanol to electricity, which - as will be seen later on - depends on its operating point. A rough idea how the system works can be demonstrated as follows. Supposing that the fuel cell, working with 50% efficiency, produces 1.7 Wh/LH₂ electrical energy, of which at least 0.7 Wh/LH₂ is left for the load providing that the electrolyzer consumes not more than 1 Wh/LH₂. This is possible because of the very low standard electrolysis voltage of methanol (only 0.016 V). In electrical engineering terms, supposing further that all hydrogen electrons are transformed to current and the fuel cell loaded voltage is about 0.7 V and a mean value of 0.4 V for the electrolyzer cell providing the hydrogen, the voltage reserve is still around 0.3 V, which can be used for the active load. In such circumstances the fuel cell power and the current are divided about equally between the electrolyzer and the active load meaning that about 50% of the fuel cell electric power is used for the active load. Supposing 50% efficiency of the fuel cell from hydrogen to electricity, the total methanol utilization efficiency is then around 25%. The same analysis holds if cell stacks with a proper voltage ratio are used in the electrolyzer and the fuel cell. In a practical assembly, like in Fig. 1, the electrolyzer and the active load are assembled in parallel rather than in series using controllable DC/DC converters. The current and power of the fuel cell is then divided according to the parallel resistance law allowing independent control of the electrolyzer current. The DC/DC converters and other plant devices needed for practical operation may increase the own energy losses and decrease the total efficiency. As shown in the experimental part later on, we can come relatively close or even exceed the above estimated total efficiency value, which is typical for DMFC today.

Because no oxygen is present at the electrolyzer cathode and the cathode is at a low potential, CO is not produced from permeated methanol like it may happen in DMFC. Thus poisoning of the Pt catalyst in the electrolyzer is not a serious concern. In fact, according to our experimental results the methanol concentration in MeOH-water solution can easily be increased to 30–40 vol-% (7.4–9.9 M), or even higher, without a noticeable poisoning effect. However, as can be seen later on in Fig. 5, increasing the methanol concentration is not beneficial without increasing the current density at the same time. This is due to the fact that the same power consumption (current × voltage) is obtained in a certain low methanol concentration using a low current density and in a higher concentration using a higher current density. The later combination is more beneficial because more hydrogen is

produced with the same energy. Increasing the temperature to 40–50 °C from normal room temperature also radically decreases the energy needed for electrolysis and is thus an important part of the practical realization of the concept. The needed heat power can be obtained from the heat loss of the electrolyzer and the fuel cell. Some methanol and carbon dioxide leaks to the cathode side like in DMFCs, which may cause problems in hydrogen purity if the product gas is not cleaned. The methanol concentration in the permeated aqueous methanol solution on the cathode side is the same as on the anode side, which allows recycling of the permeated liquid directly from the cathode to the anode. On the other hand, according to [5], methanol in the permeated solution does not transfer to the gas, but the gas contains as impurity only some 3–4% carbon dioxide, which usually does not restrict its use in a PEMFC. This can be ensured by streaming the gas through a water bed.

Operation of the system

A control system is needed to allow autonomous operation of the system, i.e. starting, running, and stopping the system. It is not just enough to connect the electrolyzer and PEMFC in a loop, because such a loop is not stable but slides gradually towards the zero power operation point. Furthermore, by active control the system can be kept at the optimal efficiency operating point in which the methanol consumption for a given power output (Wh) is minimized. The needed electronic control system is not considered in detail here, but it is a relatively simple and straightforward to realize using a microcontroller and controllable DC/DC converters as shown in Fig. 1.

Controlling the hydrogen production in an electrolyzer is straightforward by controlling its current. Provided that the electrolyzer does not leak it is also a very effective current to hydrogen converter, where almost all of the electrons released in methanol decomposition are transferred to the hydrogen output. Supposing that the fuel cell utilizes all the produced hydrogen its total current at the output is thus approximately

the same as the electrolysis current when summing up the cell currents in stacked constructions. Supposing this is valid, the current I_{el} needed at the electrolyzer to maintain a certain current I_{load} at the load can be calculated (see Fig. 1) from the current balance at the output of the fuel cell as in Equation (1)

$$I_{el} = k/(k - 1) * I_{load} \quad (1)$$

where k is the voltage down-scaling of the DC/DC converter. Here I_{load} denotes the load current before the DC/DC converter (see Fig. 1). From Equation (1) it is seen that the DC/DC-voltage ratio k has a strong non-linear relationship to the electrolyzer current. The nominal voltages of the electrolyzer and the fuel cell should be chosen so that $k > 2$ to ensure a sufficient control margin. Additionally, the non-linearity is smoother when $k \gg 1$. On the other hand the energy efficiency of DC/DC converters varies with k , typically between 95 and 90%, and have usually the best value (smallest losses) when $k < 10$. Therefore it is advisable to design the system for $2 < k < 10$. If stacking of cells is used the ratio of the nominal operation voltages of the fuel cell and electrolyzer stacks should satisfy this requirement.

The net power W_{net} obtained from the system (without DC/DC and other losses) can be calculated approximately from Equation (2)

$$W_{net} = (V_{fc} - V_{el}) * I_{el} \quad (2)$$

where V_{el} is the electrolyzer and V_{fc} the fuel cell voltage respectively. Since the voltages depend on the internal resistance of the electrolyzer and the operational point of the fuel cell, W_{net} has a maximum, which can be obtained by choosing the operational point properly.

Thermodynamic basis of the electrolyzer-fuel cell concept

In a system where methanol electrolyzer and hydrogen fuel cell are combined two electrochemical reactions take place

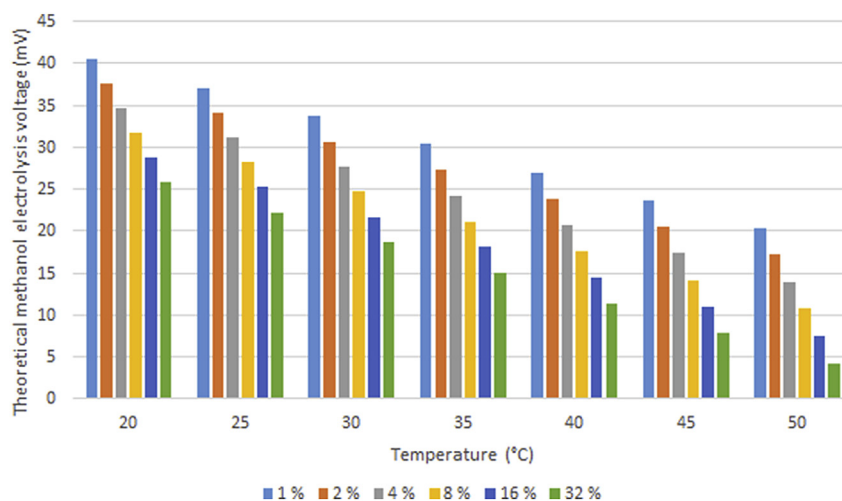
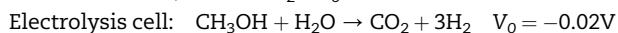
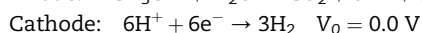

Fig. 2 – Simulation results showing theoretical electrolysis voltage as a function of temperature (°C) and methanol concentration (vol-%). Note that the current density does not affect the electrolysis voltage (see Equation (3)).

simultaneously. In an electrolyzer unit methanol is split to carbon dioxide and hydrogen, which is further oxidized to water in a fuel cell unit. All together the net reaction in the system is the same as in a direct methanol fuel cell. The basic reactions when aqueous methanol electrolysis is concerned are:

Electrolysis of methanol:



Hydrogen fuel cell

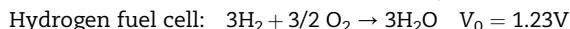
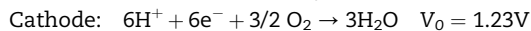
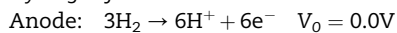

Combined electrolyzer-fuel cell:

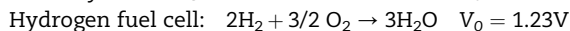
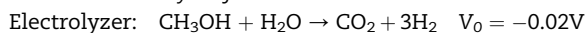

System: $\text{CH}_3\text{OH} + 3/2\text{O}_2 \rightarrow \text{CO}_2 + 2\text{H}_2\text{O}$ $V_0 = 1.21\text{V}$ where V_0 is the standard voltage of the reaction.

The theoretical electrolysis voltage (V), needed for the electrical reformation of methanol, can be calculated from the Nernst equation in Equation (3)

$$V = V_0 - \frac{RT}{n_e F} \ln \frac{a_{\text{CO}_2}}{a_{\text{CH}_3\text{OH}}} \quad (3)$$

where V_0 is the standard electrolysis voltage, R the universal gas constant, T the temperature, n_e the amount of transferred electrons and F Faraday's constant. Activities of carbon dioxide and methanol are a_{CO_2} and $a_{\text{CH}_3\text{OH}}$, respectively, and activities of water and hydrogen are set to 1. This means, in practice, that on the cathode side pure hydrogen gas at the pressure of 1 bar is expected. When the concept of ideal solution is used for methanol-water mixture the activity of methanol can be expressed with concentration. The activity of carbon dioxide in methanol water solution is defined from the phase equilibrium of gaseous carbon dioxide in ambient air with the amount dissolved into water solution as described in Equation (4)

$$\mu_{\text{CO}_2(\text{g})} = \mu_{\text{CO}_2(\text{a})} \quad (4)$$

where $\mu_{\text{CO}_2(\text{g})}$ is a chemical potential of carbon dioxide in gas phase and $\mu_{\text{CO}_2(\text{a})}$ a chemical potential of dissolved carbon dioxide. The activities are defined using ideal gas mixture and ideal solution assumptions for the phases leading to use of Henry's law in equilibrium of dissolved carbon dioxide and carbon dioxide gas. Because the methanol–water reservoir is open to air (ventilated) and the fuel mixture is circulated between the electrolyzer and the reservoir, it can be assumed that carbon dioxide gas produced in the electrolyte is the only gas present on the anode side. Assuming constant pressure the amount of dissolved carbon dioxide is also constant in a given temperature and methanol concentration. In the following calculations the pure carbon dioxide atmosphere of 1 bar is used. Using these assumptions and above equations the theoretical electrolysis voltage of methanol can be calculated as a function of temperature and methanol concentration. The activity of dissolved carbon dioxide is

estimated by the aid of Henry's law of solubility in pure water. The solubility of carbon dioxide gas in water as a function of temperature has been calculated by HSC Chemistry Software (version 6.1). The results are presented in the third column of Table 1. The corresponding Henry's constants and activities of dissolved carbon dioxide were calculated from these solubility values and are presented in the second and fourth columns in Table 1, respectively. The activities were then used to calculate theoretical electrolysis voltages (V), which are depicted in Fig. 2. This calculation doesn't take into account the influence of methanol on the solubility of carbon dioxide. To find out the influence, the solubility values calculated by the HSC software were compared to a corresponding measured data found in literature [22] (column 5 in Table 1). The values are in good agreement in pure water indicating that the experimental data could be used to estimate carbon dioxide solubility in methanol-water solvent, too. The difference and a correction factor between the solubility of carbon dioxide in methanol-water mixture and in pure water can be estimated by linear interpolation from temperatures and methanol concentrations based on the results in Ref. [22]. The correction multiplication factors have been calculated by way of illustration for solutions 1 v-% and 16 v-% of methanol and are presented in Table 1 in columns 6 and 7, respectively.

As can be seen in Table 1 the carbon dioxide solubility in methanol-water mixture of 16 v-% is about 1,6 times the solubility in pure water. This means that the activities of dissolved carbon dioxide gas in high methanol concentrations in Fig. 2 maybe somewhat underestimated and hence the theoretical electrolysis voltages somewhat overestimated.

It's worthwhile to note that the theoretical minimum electrolysis voltage is low, less than 50 mV depending on the temperature and methanol concentration. The experimental voltages presented in Figs. 4 and 5 later on are much higher including resistive losses in the MEA, current collectors and wire connections as well as activation and concentration losses. In practice it is not possible to reach the theoretical values, but the interesting question is how close to them it is possible to get.

Experimental

In what follows verification of the electrolyzer-PEMFC system is made experimentally by the aid of two small scale systems. The first one is the simplest case, where one single cell electrolyzer is connected to a single cell fuel cell with the same membrane size. The second case is a more practical one, where a 11 cell stacked electrolyzer is connected to a 18 cell stacked fuel cell. In this case the membrane size of the fuel cell is smaller than in the electrolyzer, but the maximum power is high enough to convert all the hydrogen from the electrolyzer to electricity obtained at reasonable current densities.

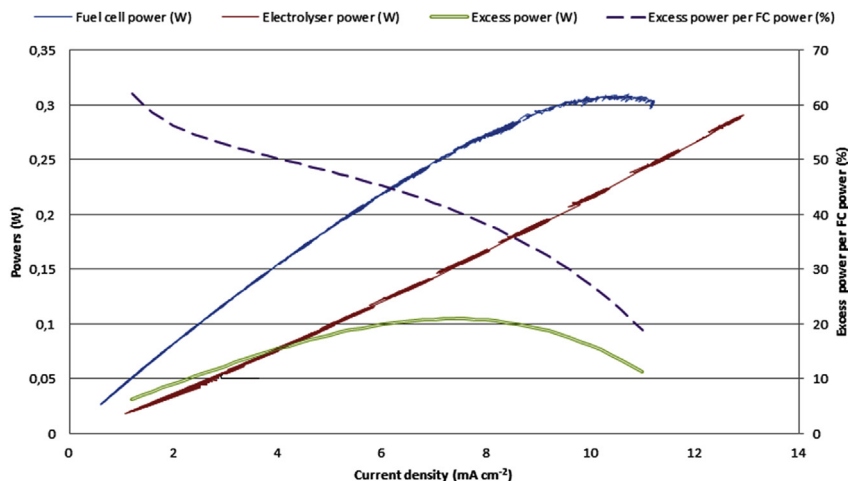

Fig. 3 – The power generated by the single cell fuel cell, blue line, and the power consumed by the single cell electrolyzer, red line, as the function of the current density. The lines are drawn by the aid of an interpolation function fitted to the measurement data. The net power is shown as green line and its percentage of the fuel cell power as the dotted line. (For interpretation of the references to colour in this figure legend, the reader is referred to the web version of this article.)

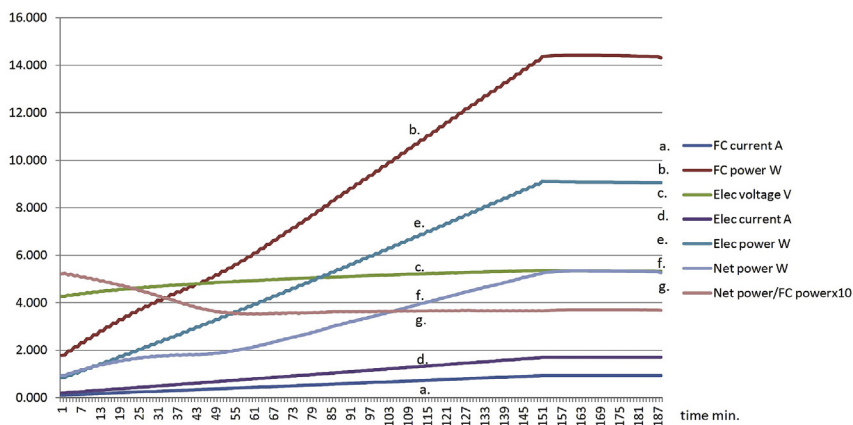

Fig. 4 – An experiment with 11 cells electrolyzer connected to 18 cells fuel cell. The horizontal axis represents time in minutes. The vertical axis represents in the same scale the currents, powers and power ratio shown in the right side of the picture. The fuel cell power demand is increased gradually and the electrolyzer current controlled accordingly. At the end of the experiment the fuel cell power demand is stabilized by setting the electrolyzer current to a constant value. The time scale is in minutes. Variables have been recorded in 2 min steps.

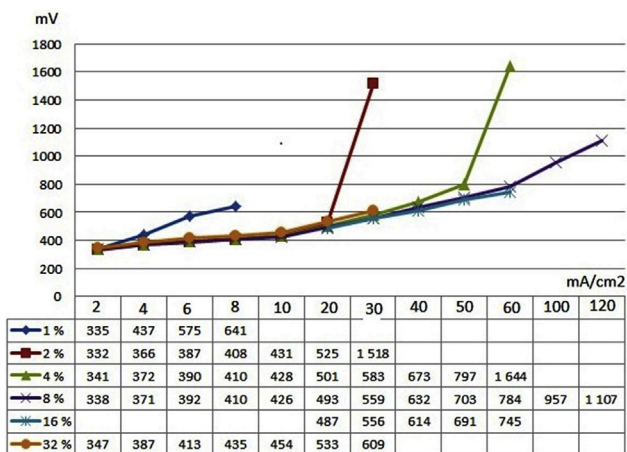

Fig. 5 – Electrolysis voltage (mV) vs. current density (mA/cm²) at different methanol concentrations (vol-%) at 20 °C.

Materials and methods

The experiments were performed using electrolyzer cells made from machined graphite bipolar plates and commercial DMFC membrane electrode assemblies (MEAs) having 50 cm² (single cell assembly) and 100 cm² (stacked assembly) active areas respectively. The 5-layer MEAs were made from a Nafion 117 membrane, catalyst layers and gas diffusion layers (GDLs). The catalyst loading was 4 mg cm⁻² Pt Ru Black at the anode, and 4 mg cm⁻² Pt Black at the cathode. The anode GDL was made of carbon cloth and the cathode GDL of ETEK ELAT. The gas and liquid channels of the bipolar plates were 2 mm wide and 1.5 mm deep, and the rib width was 2 mm. Gaskets were made of 0.32 mm thick silicone. Vertical direct channels were used in the bipolar plates in order to allow carbon dioxide to escape.

For the experiments with the single cell electrolyzer a single cell fuel cell was assembled of graphite bipolar plates, silicone gaskets and a 50 cm² MEA. The catalyst loading for the MEA was 0.5 mg cm⁻² Pt on both sides of the Nafion 117 membrane. The thickness of the silicone gaskets was 0.38 mm, and direct channels 2 mm wide and 1.5 mm deep were machined into the graphite. Steel endplates were used as current collectors both in the electrolyzer and in the fuel cell. The cells were assembled using M6 screws tightened to 6 Nm. For the experiments with the stacked electrolyzer a commercial 18 cells stacked DMFC was used (in this case with hydrogen fuel). The membrane area is about 36 cm² (estimate without opening the stack).

Methanol was circulated along the electrolyzer anode channels in order to get the produced CO₂ out from the cell and to renew the methanol concentration in it. Methanol-water solution was fed from a reservoir into the lower connector of the electrolyzer using a micro pump (Xavitech V200). It came out from the upper connector and was led back to the reservoir where the carbon dioxide and the methanol solution were separated. The H₂ gas from the cathode was fed to the fuel cell anode through a water trap and a silica dryer. The fuel cell was operated open ended with a micro-pump (Xavitech V200) pumping air to the cathode.

In both experimental systems the energy needed for air feed, fuel circulation and electrolyzer current were taken from outside sources to make the measurement results more accurate and independent from extra losses caused by plant devices like pumps, DC/DC converters and the micro controller. Loading was made using a variable resistor in the case of the single cell system and a constant current controller in the case of the stacked system. A full system built around the stacked electrolyzer and fuel cell was built and tested to verify its functionality.

Net power

Single cell system

Fig. 3 depicts measurement data from the single cell experimental system. The hydrogen produced in the electrolysis cell with a set current is fed to the fuel cell. The fuel cell is operating in open ended mode at about 20 °C. The methanol concentration of the fuel solution in the electrolyzer is 16 vol-% (3.95 M). At each set current the electric load of the fuel cell is changed to

stabilize the system to maximum power output at that load. The power curves of the fuel cell (blue) and the electrolyzer (red), have been plotted in the same figure as functions of the current density in the electrolyzer (same in the fuel cell). The net power to the load, the green curve, is the difference between the blue and the red curves. The percentage of the net power from the total fuel cell power is depicted with broken line. The point where the net power is maximized is around 7 mA cm⁻² the optimum being quite flat. The maximum net power is 100 mW, which is about 40% of the fuel cell power at this operating point. At this operational point the conversion efficiency from methanol to electricity (at the load) is not any more maximum, which can be seen when lowering the operational point to 3 mA cm⁻². At this point the excess power is about 50% of the fuel cell power. The conversion efficiency measured as the ratio of the net power to the fuel cell power is increasing accordingly when the net power is decreasing down from the maximum point. Above the maximum point both the net power and the conversion efficiency are gradually decreasing when the current density is increasing. The overall calculated efficiency from methanol to net power also varies. At the 7 mA cm⁻² maximum power point it is 1.26 Wh/mL MeOH, whereas at the 3 mA cm⁻² low power point it is 1.39 Wh/mL MeOH. Note that in this experiment the current densities are same in both cells, which is not an optimal design because a hydrogen fuel cell can operate at much higher current densities than an electrolyzer. The equal sizes were chosen to simplify the illustration of the behavior of the coupled system. The test was done in open air room environment in the ambient temperature to eliminate the effect of an extra heat either from outside or generated by the reactions inside. Because of a small power used (max. 300 mW) the heat generated by the chemical reactions is minimal in such circumstances and is transferred to the environment letting the both devices about the same ambient temperature.

Stacked cells system

In the experiment depicted in Fig. 4 the 11 cells stacked electrolyzer is connected to the 18 cells stacked fuel cell. In this case the anode output is controlled by a purge valve. Fig. 4 depicts the behavior of the combination when the current of the fuel cell is gradually increased from 0.11A to 0.94 A (power from 1.8 W to 14.1 W) using 2 min time steps. The electrolyzer current is controlled accordingly to supply the sufficient amount

Table 1 – Activities of dissolved carbon dioxide.

Temperature (°C)	Henry's constant (MPa) ^a	Solubility of CO ₂ in water ^b	Activity of dissolved CO ₂ (mol/l) ^a	Solubility of CO ₂ in water ^c	Correction factor, 1 v-% MeOH ^d	Correction factor, 16 v-% MeOH ^d
20	115	0,0008725	0,04847			
25	132	0,0007568	0,04204	0,000756		
30	151	0,0006628	0,03682	0,000713	1,2	1,6
35	171	0,0005861	0,03256	0,000608	1,1	1,6
40	191	0,0005228	0,02904	0,000531	0,97	1,6
45	213	0,0004700	0,02611	0,000470	0,83	1,6
50	235	0,0004257	0,02365	0,000399	0,66	1,5

^a Calculated from solubility of CO₂ data estimated by HSC Chemistry Software.

^b Estimated by HSC Chemistry Software.

^c Data from Schüler et al. [22].

^d Interpolated data from Schüler et al. [22]

of hydrogen. The current at each set point correspond the hydrogen consumption calculated from the fuel cell load current. Unlike in Fig. 3 the responses are drawn now on the time scale to demonstrate the dynamic and control behavior of the system. During the experiment the temperature in the electrolyzer rises from 23.3 °C to 28 °C. As can be seen the dynamics is fast and the system is in steady state almost immediately after each change of the set point. Behavior during the 3 h experiment is similar to the steady state behavior in Fig. 3 when the current density is below the maximum net power point. The maximum net power 5.35 W (486 mW/cell) in the experiment is obtained at 26 mA/cm² (fuel cell) instead of 7 mA/cm² in the single cell experiment. The system was stabilized to this level at the end of the experiment to see how well a constant electrolyzer current keeps the system stable. The electrical efficiency at this point (net power/FCpower) is 37% instead of 40% in the single cell experiment. The cell voltages at the maximum points are 484 mV in the stacked electrolyzer and 410 mV in the single cell electrolyzer case respectively. The overall calculated efficiency from methanol to electricity is in this experiment 1.09 Wh/mL MeOH when calculated over the whole experiment. Note that this is lower than in the single cell experiment. This is probably due to dynamic nature of the experiment and higher flow resistances in the system being more close to a practical application. As a reference, the manufacturer of a commercial DMFC announces 1.1 Wh/mL MeOH for their product (EFOY by SFC Energy). Note that these figures means about 30% overall energy conversion.

In spite of different electrolyzers and fuel cells used to build up the combined systems, they behave generally very similarly. Note that capability to produce net power cannot be compared directly, but one can make a scale-up calculation by multiplying by $2 \times 11 = 22$ the single fuel cell net power to estimate the net power of an assembly which correspond the stacked assembly. This gives about 2.2 W for the maximum net power at 40% efficiency. At the same efficiency the current density in the stacked system is about the same as in the single cell system. The net power is about 1.8 W, which is quite close to the above value.

Effect of methanol concentration

As mentioned earlier, the electrolysis of methanol can be done without noticeable catalyst poisoning problems when using high methanol concentrations. Additionally, an interesting observation is that higher current densities can be applied at higher concentrations without increasing the electrolysis voltage above an unacceptable level, i.e. the internal resistance of the electrolyzer decreases when the methanol concentration increases. Fig. 5 depicts the results from experiments done with 1–32 vol-% (0,25–7,90 M) solutions in the single electrolysis cell. As can be seen the electrolysis voltage at a certain current density first decreases when the concentration increases and then again increases when the concentration reach the highest value. The theoretical model in Section 3 indicates only degreasing tendency, which is stronger than in the experiment. The reason is that the theoretical model doesn't take into account the complex mass transfer phenomena which happen on the anode electrode. Additional transfer resistance causing by these phenomena

is dependent on the methanol concentration and is not behaving linearly when the concentration changes. The behavior is real and cannot be explained by measurement uncertainty because the voltage and current measurements are very accurate with less than 0.5% error and the test solutions were prepared with a good laboratory practice with error less than 1% in concentration.

An interesting practical thing to note is that at a certain methanol concentration there is an upper limit beyond which the electrolysis current cannot be increased since the voltage increases then rapidly and radically. This is probably also a mass transfer effect due to lack of methanol molecules near the anode observed also by Take et al. [5]. This phenomenon promotes the use of high concentrations in the electrolyzer. Note, however, that a high methanol concentration, although it makes the energy content of the fuel high, is not the only criteria, which should be taken into account when optimizing the whole system. The water balance, for example, is important as well as the temperature of the electrolyzer. Water is consumed when methanol is split down in the electrolyzer. The highest methanol concentration in the fuel is about 67% after which extra water is needed to maintain the reaction. This extra water may be taken from the fuel cell cathode when hydrogen is oxidized. In high methanol concentrations the risk of CO forming in the anode of the electrolyzer increases, which in turn increases the risk of poisoning the catalyst, although observation is that an electrolyzer can tolerate much higher methanol concentrations than a DMFC. The effect of temperature is considered in more detail in the next chapter.

Effect of temperature

Increasing the temperature of the fuel solution can be expected to lower the power needed for the electrolysis as was shown earlier by the theoretical analysis (Fig. 2.). This can also be observed experimentally. Fig. 6 depicts the electrolysis voltage vs. temperature in 16 vol-% (3,95 M) solution at three different current densities. As can be clearly seen the electrolysis voltage decreases at all current densities when increasing the temperature. A temperature around 50 °C is still quite moderate and can be obtained in practice by

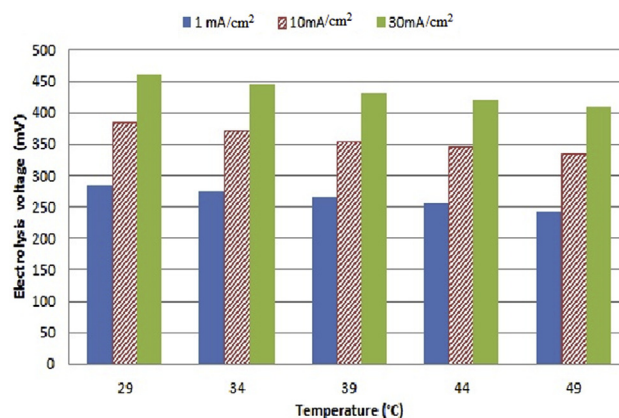

Fig. 6 – Electrolysis voltage (mV) vs. temperature (°C). Using a 16 vol-% aqueous methanol solution.

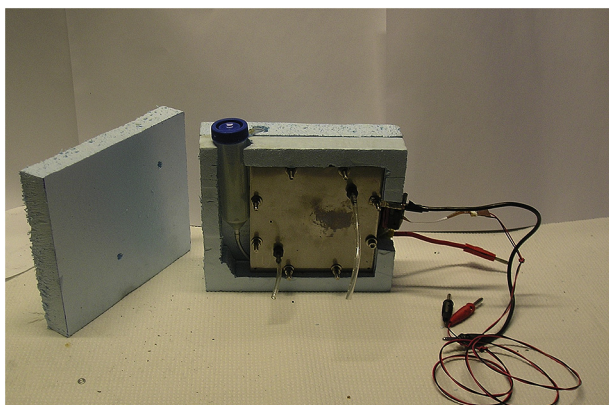

Fig. 7 – An experimental electrolyzer cell and a methanol container covered by heat insulation.

utilizing the waste heat produced by the electrolyzer using heat insulation as shown in Fig. 7.

Comparison to DMFC - what can be gained?

It is obviously interesting to compare the presented concept to the standard DMFC. Both use quite the same technical components and perform the same basic function, i.e. convert methanol to electricity. A comparison can be done in several ways from several points of view.

Comparison through modeling the performances

Because the net electrochemical reaction is the same in both systems it is not rational to compare the efficiencies of the two

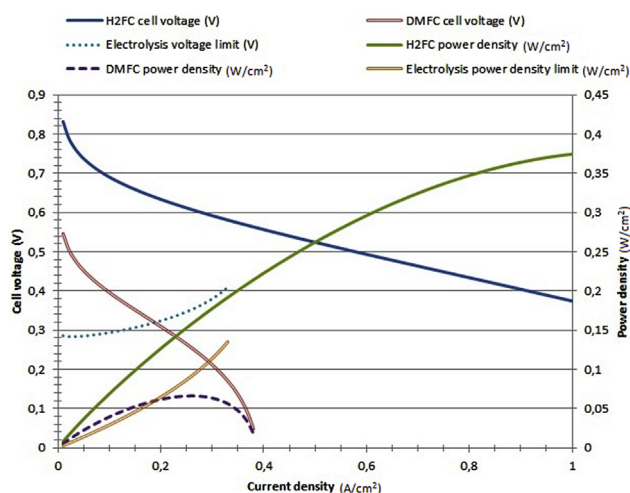

Fig. 8 – Comparing the DMFC and PEMFC voltage and power outputs as functions the current density on the membrane. The combined electrolyzer-PEMFC produces an equal amount of power as a DMFC when the electrolyzer voltage is on the “Electrolysis voltage limit” curve shown in the figure. Below the curve the net power produced by the combined system is larger than the DMFC power and above the curve it is smaller.

concepts using the reaction equations. Neither it is not rational to compare them in an experimental setup, because so many different experimental setups can be made. A more realistic and generic comparison can be done using reliable generally accepted experimental data and models from literature for DMFCs and PEMFCs. Fig. 8 depicts DMFC and PEMFC cell voltages in the same plot as the functions of the current density in both fuel cells. The same current density means that the fuel is oxidized at the same rate in both cases. In the case of DMFC the fuel is aqueous methanol and in the case of PEMFC it is hydrogen produced by the electrolyzer. Supposing that all electrolysis current is converter to hydrogen electrons and hydrogen is used 100% in the fuel cell, the electrolyzer current is about the same as the fuel cell current (the density depends on the membrane size) and the methanol consumption rate is the same as in the DMFC at the same current (crossover losses not included). The presented performance or polarization curves have been calculated using common semi-empirical models in literature both for DMFCs and PEMFCs. For the DMFC the following equation has been used (Equation (5)) [15]:

$$V_{\text{cell}} = V_o - b_{\text{cell}} \log i - R_e i + C_1 \ln(1 - C_2 i) \quad (5)$$

where

$$b_{\text{cell}} = \frac{2.303RT}{F} \left(\frac{1}{\alpha_A} + \frac{1}{\alpha_C} \right), C_1 = \frac{NRT}{\alpha_A F}, C_2 = \frac{1}{n_e F k_{\text{eff}} C_{\text{ME}}}$$

$$V_o = V_{\text{ocell}} - \frac{RT}{\alpha_C F} \ln \left(\frac{p_O^{\text{ref}}}{i_{\text{OC}} (p_O)^{N_O}} \right) - \frac{RT}{\alpha_A F} \ln \frac{C_{\text{ME}}^{\text{ref}}}{i_o C_{\text{ME}}^N}$$

Here V_{cell} is the cell voltage, i current density, R gas constant, T temperature of the cell, F Faraday's constant, α_A and α_C the transfer coefficients for the oxidation of methanol and oxygen, respectively, R_e the internal cell resistance, N a reaction order for methanol oxidation, n_e the number of transferring electrons, k_{eff} an effective mass transport coefficient for the anode side of the cell, C_{ME} the methanol concentration, V_{ocell} the standard potential for DMFC overall reaction, i_{OC} the cathodic exchange current density at the reference oxygen pressure p_O^{ref} , p_O the oxygen pressure, N_O the reaction order for oxygen reduction and i_o the anodic exchange current density at reference concentration $C_{\text{ME}}^{\text{ref}}$.

For the PEMFC the semi-empirical model [16,17] is used (Equation (6)):

$$V_{\text{cell}} = 1.229 - 0.85 \times 10^{-3} (T - 298.15) + 4.3085 \times 10^{-5} T (\ln p_{\text{H}_2} + 0.5 \ln p_{\text{O}_2}) - \left(\frac{\lambda_A - \lambda_C}{\lambda_A \lambda_C} \right) \frac{RT}{n_e F} \ln \frac{i}{i_o} - i \left(\beta_1 \frac{i}{i_m} \right)^{\beta_2} - i R_e \quad (6)$$

where T is the cell temperature, p_{H_2} and p_{O_2} hydrogen and oxygen partial pressures, λ_A and λ_C anode and cathode transfer coefficients, respectively, i_o exchange current density, R_e internal cell resistance, i current density, i_m limiting current density and β_1 and β_2 constants of concentration overpotential.

The parameters used in the calculations are listed in Table 2. The parameters for the DMFC have been taken from Ref. [15]. They have been fitted into the measurement data of a DMFC with air fed cathodes at ambient pressure and with a methanol concentration of 1 M. The cell temperature is 60 °C. The performance of the PEMFC has been calculated with cell

Table 2 – Parameters used to calculate the performance characteristics for a DMFC (Eq. (5)) and a PEMFC, (Eq. (6)) [15,17].

Parameters for methanol fuel cell (Eq. (5))		Parameters for hydrogen fuel cell (Eq. (6))	
T (°C)	60	T (°C)	25
Oxygen pressure (bar)	0.21	p _{H2} (bar)	1.0
V _O (V)	0.33	p _{O2} (bar)	0.21
b (V dec ⁻¹)	0.11	λ _A	0.5
R _e (Ω cm ²)	0.192	λ _C	1.0
C ₁ (V)	0.085	i _m (A cm ⁻²)	2.2
C ₂ (cm ² A ⁻¹)	2.5	β ₁	0.3
		β ₂	2
		i ₀ (A m ⁻²)	0.00001
		R _e (Ω cm ²)	0.192
		n _e	2
		F (C mol ⁻¹)	96,485
		R (J mol ⁻¹ K ⁻¹)	8.314

temperature of 298.15 K, hydrogen pressure of 1 bar and with ambient air at the cathode. For the exchange current density a value of 1×10^{-5} A m⁻² has been used. All the other parameters have been taken from Ref. [17].

The difference in the cell voltages at a same current density in Fig. 8 indicates the amount of power available for electrolysis to produce the hydrogen needed in the PEMFC and still produce the same net power than the DMFC. If this power is higher than the electrolysis needs then the net power from the combined system is higher than the power from a DMFC at the same current density. In the case the power is smaller the situation is vice versa. This critical power curve is called *electrolysis power density limit* in Fig. 8. Knowing the critical power it is straightforward to draw a curve showing the maximum electrolysis voltage at each current density below which the combination produces more net power than the DMFC and above which the situation is vice versa (note that the current density at x-axis refers to the fuel cell current density NOT to the electrolyzer current density which can be different). This curve is called *electrolysis voltage limit-curve* in Fig. 8. If the electrolysis voltage is kept under this curve also the utilization of methanol is more effective in the combination system, because its consumption is directly related to the current in both cases by the same factor (losses through crossover of methanol not included). Because electrolysis voltages on the curve are well above the theoretical Gibbs energy of the electrolysis, one can regard them practically attainable. The values on y-axis concerns one single cell. The actual values in a stacked system have to be calculated by multiplying the values by the number of cells in the stack. Because the DMFC models and data typically are limited under 0,5 A/cm² but those of PEMFC under 1 A/cm², the picture has been drawn to indicate the electrolyzer – PEMFC combination could work in this higher current scale, too. In this scale comparison cannot be made any more, but one can estimate the maximum electrolyzer power available for a given net power and the electrolysis voltage calculated accordingly.

Both the single cell and stacked cell experiments in Section 4.2.1 and 4.2.2 respectively are easy to position into the very low part of x-axis. In both cases the electrolysis voltage is over 400 mV and thus over the electrolysis voltage limit, which is

about 280 mV in this range of x-axis (see Fig. 8). This indicates that the DMFC would be more effective than the combination in both of cases. Could the situation be changed by changing some parameters of the systems? In the single cell case, because the structure is fixed not too much can be done, but in the stacked cell case that can be done by enlarging the total membrane area of the electrolyzer. Increasing temperature at the same time less enlargement is needed. In practical applications in higher fuel cell current densities, say 250–300 mA/cm², where a DMFC attains the maximum power, the electrolysis voltage limit is around 400 mV. This could be well obtained with the stacked electrolyzer by increasing only the temperature about 10 °C (see Fig. 6).

Comparison by estimating the physical volumes

Another interesting way to compare the two concepts is the physical size. This is complicated without making a careful mechanical design. However, something can be said by estimating the stack sizes needed in both cases. Taking into account the experimental data above one can conclude that in an optimal electrolyzer – PEMFC system the fuel cell membrane size can be made much smaller than the one of the electrolyzer due to the high current density of the hydrogen fuel cell. This means that in practice the volume taken by the electrolyzer dominates the total volume. Note that the experimental data above have been recorded with rather low current densities because the electrolysis voltage in the used equipment have tendency to increase with the increasing current density. This indicates that a great part of the voltage is due to the electrical losses in the mechanical construction of the electrolyzer. With a careful design and assembly these losses can be minimized. From Fig. 8 one can conclude that the stack sizes of a DMFC and PEMFC producing a same electrical power is roughly in relation 2.5:1. However, when combined with the electrolyzer the PEMFC has to produce in addition to the actual load power also the electrolyzer power, which means that its maximum electrical power has to be doubled. Probably, however, we would end up somewhat smaller size PEMFC stack than in the case of DMFC. The following design example illustrates the situation.

Supposing we use MEAs with 100 cm² active area and stack 11 cells having 50 mA cm⁻² current density in the electrolyzer. Thus we get a hydrogen output, which corresponds to a hydrogen production of 55 A. This is around 22.9 LH₂/h. The total voltage of the electrolyzer stack is around 4.5 V (cell voltage 409 mV) at 35–40 °C. A commercial small scaled fuel cell (e.g. H-30, Horizon fuel cell technologies) using this hydrogen produces around 30 W with a rated performance of 8.4 V at 3.6 A. It has a membrane size of about 7 cm² stacked in 14 cells. The current density of the fuel cell is approximately 500 mA cm⁻² at this operating point with cell voltages of around 0.6 V. Supposing that the net power for the load is 40% of the fuel cell power, then the output of the combined system is around 10 W. Note that we are above the common current density range of the hydrogen fuel cell and DMFC in Fig. 8, but we can compare this calculation with a virtual DMFC using 100 cm² MEAs having the same nominal power and the current density of 50 mA cm⁻² than the electrolyzer. From the load curve in Fig. 8 it can be concluded that the voltage of a

single cell would be around 0.4 V and we would need 5–6 cells to obtain a 2 V output voltage, which together with 5 A current would give the same output power. The number of cells are thus about half of those in the electrolyzer. The number or the size of cells could be even smaller if the DMFC is operating in its maximum power point (250 mA cm^{-2}). The number of cells needed in an electrolyzer stack for a certain hydrogen production depends on the maximum current density that can be used while keeping the power consumption small enough. Here we have used 50 mA cm^{-2} , because this value seems realistic according to the experiments presented previously. In the combined system the electrolyzer and the fuel cell can be stacked in the same stack to save volume and weight. This simplifies further the technical construction and also makes it easier to utilize the waste heat produced by the fuel cell to heat up the whole system. As a result of the stacking, the stack size of the combined system is approximately the size of the electrolyzer stack plus the volume of the fuel cell stack. It can be estimated to be roughly double of the size of DMFC producing the same power.

As a summary, the above analysis is of course only one way to compare the two concepts, but it shows that combining electrolysis and PEMFC can compete with DMFC provided that the electrolysis voltage can be made small enough. In addition, it can operate in higher methanol concentration and has a better overall power efficiency (Wh per ml MeOH) under certain conditions. The physical volume of the components needed for both concepts are more difficult to compare, but it seems that the stack size of the combined system becomes inevitably larger than a DMFC having the same power output. How much depends on how well the electrolyzer is designed to minimize the electrical resistance between the electrodes.

Summary and discussion

We have presented a novel idea for making electricity from methanol by using a combination of a PEM electrolyzer and a PEM fuel cell. The system can be made autonomous when the components are designed properly and the control system needed to maintain the balance in the system is included. Compared to the systems, where reforming of methanol is made at high temperatures, this concept provides a solution at low temperatures and for such applications where this is fundamental, e.g. in portable devices handled by humans. The concept also has interesting features compared to DMFCs. In certain conditions the efficiency in producing electricity from methanol could be somewhat higher. This is due to the fact that production of hydrogen can be done using very low electrolysis energy on the one hand, and on the other hand a PEM H_2 fuel cell is more efficient than a DMFC. Raising the temperature from the ambient temperature up to 50–60 °C still decreases the energy needed for electrolysis. As a consequence, conversion of methanol to hydrogen as an intermediate stage is rational. In an electrolyzer the cathode electrode is in a lower potential and no air is involved, which seems prevent effectively forming of CO from the crossover methanol. At anode forming of CO can in principle happen, but because of large presence of OH ions due to the dissociation effect of electrolysis potential it is oxidized effectively to

CO_2 [18,19]. Ru doping can be still used at anode to protect it like in DMFC. According to our experience the methanol concentration at the electrolyzer anode can be increased without the risk of poisoning the Pt catalyst to much higher concentrations than in DMFC. From a practical point of view the possibility to operate the system using higher methanol concentrations without water dilution is an important feature, because it simplifies the technical construction. If compared to DMFC the total stack size seems to become 2–3 times as large. How much larger in practice is a question mark still because no relevant comparison in practice has been done this far. The overall energy efficiency from methanol to electrical energy obtained in the experiments varies from 1.09 to 1.39 Wh/mLMeOH the lower value being a more realistic one. This may be compared to a value of a commercial DMFC (EFOY, SFC Energy) 1.1 Wh/mL MeOH.

The current densities used in electrolysis experiments have been relatively low, which means large cell and stack volumes. Minimizing all transfer resistances and lifting the temperature to 50–60 °C allows the power density values to be increased and still keeping the electrolysis voltage small enough. This means that the power density values per weight and volume of the whole system can probably be increased. At the moment it is not yet clear to the authors how high the power densities can be in practice.

The engineering work is continuing to make the system usable. Such questions like increasing cost and possible higher failure rate caused by the increased number of components should be considered and solved properly. An interesting question is also whether we can replace methanol with ethanol. Preliminary experiments indicate that electrolysis of aqueous ethanol solution produces hydrogen but most probably also byproducts like acetaldehyde and acetic acid. We do not have enough experimental data at the moment to show how harmful these byproducts are in the process or whether we can obtain low enough energy values for the electrolysis to make the concept work with ethanol.

Acknowledgments

The authors are grateful for financial support from the Fuel Cell and Hydrogen Joint Undertaken FCH-JU (Contract No 254294) and from Aalto University MIDE program (IPPES Project Grant).

REFERENCES

- [1] Agrell J, Birgersson H, Boutonnet M, Melián-Cabrera I, Navarro RM, Fierro JLG. Production of hydrogen from methanol over Cu/ZnO catalysts promoted by ZrO_2 and Al_2O_3 . *J Catal* 2003;219:389–403.
- [2] Morse JD, Upadhye RS, Graff RT, Spadaccini C, Park HG, Hart EK. A MEMS-based reformed methanol fuel for portable power. *J Micromech Microeng* 2007;17:S237–42.
- [3] Chan SH, Wang HM. Thermodynamic and kinetic modelling of an autothermal methanol reformer. *J Power Sources* 2004;126:8–15.

- [4] Jeffries-Nakamura B, Narayanan SR, Valdez TI, Chun W. Making hydrogen by electrolysis of methanol. *NASA Tech Brief* 2002:26.
- [5] Take T, Tsuratani K, Umeda M. Hydrogen production by methanol-water solution electrolysis. *J Power Sources* 2007;164:9–16.
- [6] Sasikumar G, Muthumeenal A, Pethaiaha SS, Nachiappan N, Balaji R. Aqueous methanol eletrolysis using proton conducting membrane for hydrogen production. *Int J Hydrogen Energy* 2008;33:5905–10.
- [7] Hu Z, Wu M, Wei Z, Song S, Shen PK. Pt-WC/C as a cathode electrocatalyst for hydrogen production by methanol electrolysis. *J Power Sources* 2007;166:458–61.
- [8] Campanari S, Macchi E, Manzolini G. Innovative membrane reformer for hydrogen production applied to PEM micro-cogeneration: simulation model and thermodynamic analysis. *Int J Hydrogen Energy* 2008;33:1361–73.
- [9] Cloutier CR, Wilkinson DP. Electrolytic production of hydrogen from aqueous acidic methanol solutions. *Int J Hydrogen Energy* 2010;35:3967–84.
- [10] Uhm S, Jeon H, Kim TJ, Lee J. Clean hydrogen production from methanol-water solutions via power-saved electrolytic reforming process. *J Power Sources* 2010;198:218–22.
- [11] Pham AT, Baba T, Sugiyama T, Shudo T. Efficient hydrogen production from aqueous methanol in a PEM electrolyzer with porous metal flow field: influence of PTFE treatment of the anode gas diffusion layer. *Int J Hydrogen Energy* 2013;38:73–81.
- [12] Pham AT, Baba T, Shudo T. Efficient hydrogen production from aqueous methanol in a PEM electrolyzer with porous metal flow field: influence of change in grain diameter and material of porous metal flow field. *Int J Hydrogen Energy* 2013;38:9945–53.
- [13] Tuomi S, Santasalo-Aarnio A, Kanninen P, Kallio T. Hydrogen production by methanol-water electrolysis with an alkaline membrane cell. *J Power Sources* 2013;229:32–5.
- [14] Avgouropoulos G, Ioannides T, Kallitsis JK, Neophytides S. Development of an internal reforming alcohol fuel cell: concept, challenges and opportunities. *Chem Eng J* 2011;176–177:95–101.
- [15] Scott K, Jackson C, Argyropoulos P. A semi empirical model of the direct methanol fuel cell. Part II. Parametric analysis. *J Power Sources* 2006;161:888–92.
- [16] Mann RF, Amphlett JC, Hooper MAI, Jensen HM, Peppley BA, Roberg PR. Development and application of a generalized steady-state electrochemical model for a PEM fuel cell. *J Power Sources* 2000;86:173–80.
- [17] Zhang X, Guo J, Chen J. The parametric optimum analysis of a proton exchange membrane (PEM) fuel cell and its load matching. *Energy* 2010;35:5294–9.
- [18] Gong XQ, Hu P. The catalytic role of water in CO oxidation. *J Chem Phys* 2003;119(12):6324–34.
- [19] Pham AT, Shudo T. Efficient hydrogen production from aqueous methanol in a proton exchange membrane electrolyzer with porous metal flow fields. *Int J Automot Eng* 2012;3:125–30.
- [20] Kariya T, Hirono T, Funakubo H, Shudo T. Effects of the porous structures in the porous flow field type separators on fuel cell performance. *Int J Hydrogen Energy* 2014;39:15072–80.
- [21] Iulianelli A, Ribeirinha P, Mendes A, Basile A. Methanol steam reforming for hydrogen generation via conventional and membrane reactors: a review. *Renew Sustain Energy Rev* 2014;29:355–68.
- [22] Schüler N, Hecht K, Kraut M, Dittmeyer R. On the solubility of carbon dioxide in binary water- methanol mixtures. *J Chem Eng Data* 2012:57.