

# Antenna tuning for WCDMA RF front end

Reema Sidhwani

**School of Electrical Engineering**

Thesis submitted for examination for the degree of Master of  
Science in Technology.

Espoo 20.11.2012

**Thesis supervisor:**

Prof. Olav Tirkkonen

**Thesis instructor:**

MSc. Janne Peltonen

Author: Reema Sidhwani

Title: Antenna tuning for WCDMA RF front end

Date: 20.11.2012

Language: English

Number of pages:6+64

Department of Radio Communications

Professorship: Communication Theory

Code: S-72

Supervisor: Prof. Olav Tirkkonen

Instructor: MSc. Janne Peltonen

Modern mobile handsets or so called Smart-phones are not just capable of communicating over a wide range of radio frequencies and of supporting various wireless technologies. They also include a range of peripheral devices like camera, keyboard, larger display, flashlight etc. The provision to support such a large feature set in a limited size, constraints the designers of RF front ends to make compromises in the design and placement of the antenna which deteriorates its performance. The surroundings of the antenna especially when it comes in contact with human body, adds to the degradation in its performance. The main reason for the degraded performance is the mismatch of impedance between the antenna and the radio transceiver which causes part of the transmitted power to be reflected back. The loss of power reduces the power amplifier efficiency and leads to shorter battery life. Moreover the reflected power increases the noise floor of the receiver and reduces its sensitivity. Hence the over performance of the radio module in terms of Total Radiated Power and Total Isotropic Sensitivity, gets substantially degraded in the face of these losses.

This thesis attempts to solve the issue of impedance mismatch in RF front-ends by introducing an adaptive antenna tuning system between the radio module and the antenna. Using tunable reactive components and by intelligently controlling them through a tuning algorithm, this system is able to compensate the impedance mismatch to a large extent. The improvement in the output power and the reduction in the Return Loss observed in the measurements carried out for WCDMA, as part of this thesis work, confirm this. However, the antenna tuner introduces an insertion loss and hence degrades the performance in perfect match conditions. The overall conclusion is that the adaptive antenna tuner system improves the performance much more than it degrades it. Hence it is an attractive solution to be included in mobile terminals on a commercial scale.

Keywords: front end, impedance mismatch, antenna tuner, measurement receiver, adaptive tuning, reflection coefficient

## Preface

Now that the daunting task of developing an antenna tuner system in ST-Ericsson has come to a conclusive point, I can't help but wonder how I would have managed to come this far without the help, encouragement and guidance of my colleagues in Turku, Lund and Nuremberg offices. Most of all I would like to thank my instructor Janne Peltonen for his useful insights and for sharing his knowledge with me. Also, my sincere thanks to Jean-Louis Mendes, Michael Hirschmann, Joerg Meissner, Christina Grapsa, Bjorn Gustavsson and Jari Horkko. Next, I would like to thank my supervisor Prof. Olav Tirkkonen. His suggestions and corrections made a tremendous difference to the shape this thesis has taken.

I would like to express my heart felt gratitude to my friends in Finland, not just for their friendship but also for encouraging me to explore the unknown. Without you I would not have made it. Thanks for making my life here filled with fun and happiness.

Last but not the least, I want to thank my family for their love and trust and for constantly supporting me in all my decisions.

Otaniemi, 20.11.2012

Reema Sidhwani

# Contents

<b>Abstract</b>	<b>ii</b>
<b>Preface</b>	<b>iii</b>
<b>Contents</b>	<b>iv</b>
<b>Abbreviations</b>	<b>vi</b>
<b>1 Introduction</b>	<b>1</b>
1.1 Motivation for the research . . . . .	1
1.1.1 Impedance mismatch . . . . .	1
1.1.2 Antenna tuning . . . . .	3
1.1.3 Impedance Tuner . . . . .	5
1.2 Objective and goals . . . . .	5
1.3 Outline . . . . .	6
<b>2 Background</b>	<b>8</b>
2.1 Theory . . . . .	8
2.1.1 Impedance matching . . . . .	8
2.1.2 LC Impedance Matching Networks . . . . .	9
2.1.3 Binary capacitance array . . . . .	12
2.1.4 Measuring parameters . . . . .	13
2.2 Antenna Fundamentals . . . . .	15
2.2.1 Antenna Characteristics . . . . .	16
2.2.2 Antenna types . . . . .	17
2.2.3 Design issues . . . . .	18
2.3 Building Blocks . . . . .	18
2.3.1 Adaptive Antenna Tuner . . . . .	19
2.3.2 Bidirectional Coupler . . . . .	19
2.3.3 Measurement Receiver . . . . .	21
2.3.4 MIPI RFFE interface . . . . .	21
2.3.5 Processors . . . . .	22
2.3.6 Software . . . . .	22
<b>3 Design and implementation concept</b>	<b>24</b>
3.1 Reflection coefficient tracking . . . . .	24
3.1.1 Coexistence with other control algorithms . . . . .	26
3.2 Impedance calculation . . . . .	28
3.2.1 Equation based algorithm . . . . .	28
3.2.2 Gradient Search algorithm . . . . .	31
3.2.3 Hill Climbing algorithm . . . . .	33
3.3 Common algorithm control . . . . .	35
3.3.1 Operating modes . . . . .	35
3.3.2 Antenna tuner state machine . . . . .	36

3.4	Timing considerations . . . . .	41
3.4.1	RAT specific timings . . . . .	42
3.4.2	MIPI RFFE timings . . . . .	44
3.5	Performance degradation considerations . . . . .	45
3.5.1	Error Vector Magnitude . . . . .	45
3.5.2	Linearity . . . . .	45
3.5.3	Insertion loss . . . . .	46
3.5.4	Reflection coefficient accuracy . . . . .	46
<b>4</b>	<b>Performance and measurements</b>	<b>48</b>
4.1	Implementation and measurement set-up . . . . .	48
4.1.1	Chosen control algorithm . . . . .	48
4.1.2	Chosen antenna parameters . . . . .	49
4.1.3	Chosen frequencies . . . . .	49
4.2	Lab set-up . . . . .	50
4.2.1	Radio module and antenna tuner . . . . .	50
4.2.2	Load-pull tuner . . . . .	50
4.2.3	Network Analyzer . . . . .	51
4.2.4	Radio Tester . . . . .	51
4.3	Measurement results . . . . .	51
4.3.1	VSWR and S11 . . . . .	51
4.3.2	Output power . . . . .	52
4.3.3	EVM and ACLR . . . . .	52
4.4	Analysis . . . . .	53
<b>5</b>	<b>Conclusion</b>	<b>57</b>
5.1	Summary . . . . .	57
5.2	Discussion . . . . .	60
5.3	Future Work . . . . .	60
	<b>References</b>	<b>62</b>

## Abbreviations

RF	Radio Frequency
RAT	Radio Access Technology
MIPI	Mobile Industry Processor Interface
GSM	Global System for Mobile Communications
WCDMA	Wideband Code Division Multiple Access
LTE	Long Term Evolution
FDD	Frequency Division Duplexing
TDD	Time Division Duplexing
SMA	SubMiniature version A
LO	Local Oscillator
PA	Power Amplifier
LB	Low Band
HB	High Band
BB	Baseband
ADC	Analog to Digital Converter
3GPP	Third Generation Partnership Project

# 1 Introduction

The fastest growing segment in consumer electronics is that of Smart-phones and Tablet PCs. Key features of these devices are ubiquitous communication, continuous access and small size without compromising on the battery life. Consumers demand faster and uninterrupted internet connection as the need to be connected anytime and anywhere continues unabated. While the thirst of higher transmission rates driven by the high resolution images, videos and sound data remains unquenchable, another trend that has been growing at equal pace in the telecom industry is to include more and more functionality in the mobile handsets. Today's wireless handsets are not just expected to communicate over a wide range of frequencies and modulation schemes with high data rates but also support non-cellular services such as mobile television, Bluetooth, wireless-local-area-network (WLAN), and Global Positioning System (GPS). Though these applications need peripheral devices like a camera, a keyboard and a large display to be incorporated in the handset design, the size and power consumption is required to remain optimal. This leaves little space for RF front end components [1], especially the antenna, which is often wrapped and re-routed around the peripheral functions. Thinner form-factors and shrinking foot-prints are forcing designers to constrain antenna design to a historically small area. These constraints, along with the susceptibility to detuning environmental effects, cause a rapid variation in the input impedance of the antenna. When the input impedance changes, a mismatch occurs between the radio module and the antenna. The primary effect of such an impedance mismatch is on the efficiency of the power module since optimal energy transfer is jeopardized but there is also an impact on the modulation quality of the transmission and on the receiver sensitivity. These losses can dramatically deteriorate the performance of an otherwise well designed radio module. This thesis work addresses the problem of antenna impedance mismatch and presents a solution in the form of an adaptive impedance matching system.

## 1.1 Motivation for the research

### 1.1.1 Impedance mismatch

A radio front end consists of an antenna and components like power amplifiers, switches, filters etc. In addition, the connecting tracks between these components and the RF processing chain of the radio, are also included in the front end. When tested in isolation or in simulations, these components show accurate results in compliance with their datasheets. On the other hand, when testing is done in real life situations where the front end modules are tightly integrated with the device and the environmental effects are constantly changing, the specifications of these components can turn out to be grossly inaccurate. Impedance mismatch between the components, improper termination and losses in the cables and interconnects, are some of the reasons behind this inconsistent behavior of the front end modules.

One of the key radio performance indicators for mobile phone devices is Over The Air (OTA) performance. OTA is quantified in terms of Total Radiated Power (TRP)

and Total Isotropic Sensitivity (TIS). Both parameters are mainly determined by the performance of the antennas. Hence antennas are one of the key components of the front end and even the whole radio system and its design and characterization is crucial for the performance of the entire device. Antenna is an electrical device that converts the electric energy from an RF transmitter into an electromagnetic wave propagating in free space and vice versa. For maximum power transfer between the antenna and transmitter/receiver (transceiver), the input impedance at the antenna terminals must be the same as that at the output of the transmitter power amplifier or the receiver low noise amplifier. When a mismatch occurs in the impedance between the antenna and that of the radio transceiver, degradation happens in the antenna performance. Various factors are responsible for this mismatch. Most often the antenna design compromises the desirable impedance in favor of radiation pattern, efficiency and the size and shape of the mobile phone. Another factor is the number of bands and the frequency range that the antenna is expected to support. A pure resistive load is not frequency dependent but when the impedance of the antenna starts to have a reactive element, it also becomes dependent on the operational frequency. Figure 1 shows the variation of impedance of an example antenna in a frequency range of 600 MHz and 3 GHz. The nearby electromagnetic environment of mobile phone such as contact with human body, hand and head or presence of conductive material like metal plates, also de-tune the impedance at the antenna feeding point. The effect on detuning on the impedance of the same example antenna is shown in Figure 2.

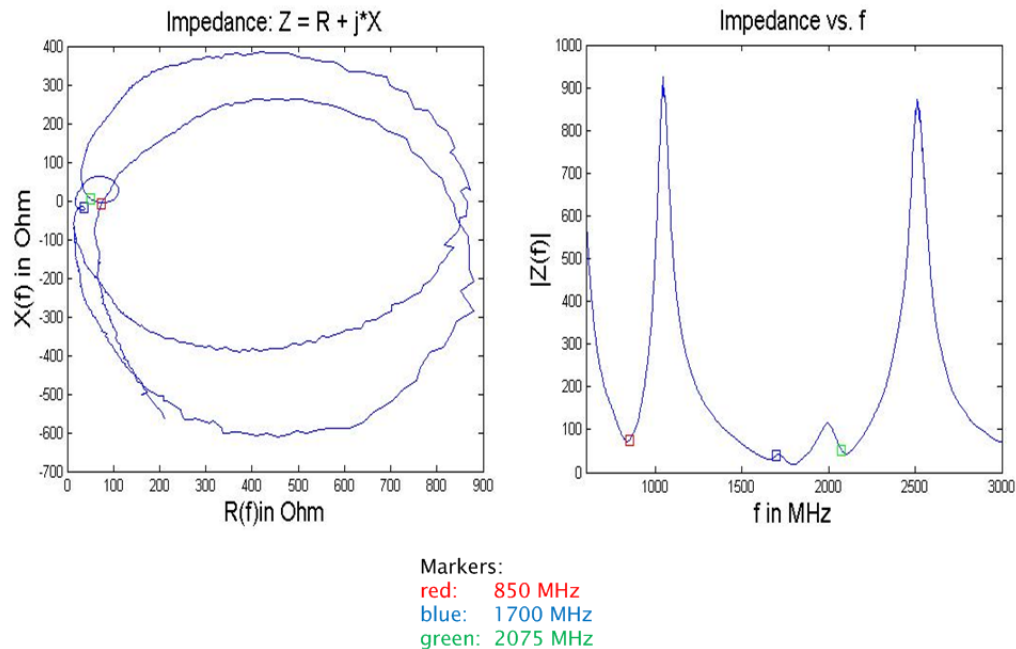

Figure 1: Impedance variation of an example antenna with frequency

The worse the mismatch the less energy will propagate from the RF engine to the antenna. This loss of power will in most cases be compensated by the power amplifier if a closed loop power control has been implemented in the mobile phone.

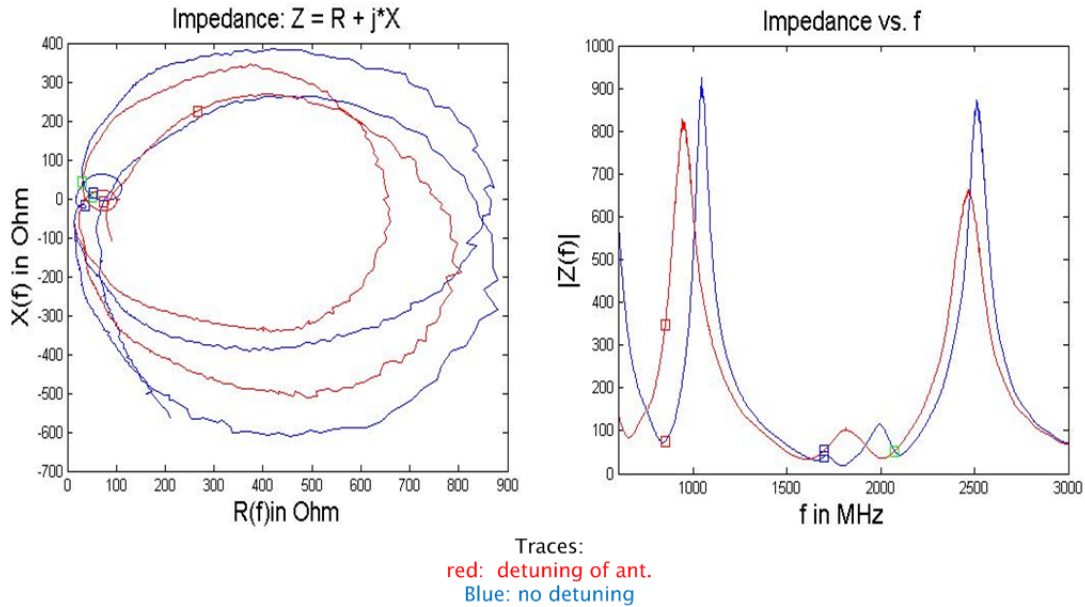

Figure 2: Impedance variation of an example antenna by detuning

But this compromises the power efficiency of the power amplifier which increases its current consumption and reduces the talk time. The mismatch also has an adverse effect on the linearity of the power amplifier causing adjacent channel leakages and spurious emissions [2]. In addition the power that is not propagated gets reflected from the antenna. This reflected power creates standing waves on the transmission line between the RF module and the antenna. Depending on the phase of the forwarded and reflected power, the voltages can either add up or subtract leading to the formation of maximum and minimum voltage points on the line. If a maximum voltage point happens to be close to the radio module, it can damage the radio parts. Moreover, this reflected power significantly raises the noise floor of the receiver, thereby degrading the receiver sensitivity [3, p. 241]. To mitigate some of the given harmful effects of impedance mismatch, an isolator is often applied between the power amplifier and the antenna to absorb the reflected signal. This isolator is a bulky and expensive component and its integration in the front end module is not straight-forward. So usage of an isolator in mobile handsets is not an attractive solution. Besides, it does not help in preserving the power efficiency and the receiver sensitivity.

### 1.1.2 Antenna tuning

The RF transceiver module in a wireless handset is designed to have an impedance of 50 ohms. Ideally, for the radio to deliver power to the antenna, the impedance of the transceiver and transmission line should be matched to that of the antenna across all frequency bands. This rarely happens because of the antenna design, the bandwidth limitations and the environment factors. One solution to improve the impedance match between a load and a source is to insert a matching network in between. By

cleverly manipulating the configuration of this matching network, it is possible to make the load impedance almost equal to the source impedance. When used in the context of antennas with dynamic adjustment of impedance, this mechanism is referred to as antenna tuning. Antenna tuning system can be Open or Closed Loop. In Open Loop antenna tuning shown in Figure 3, the matching network element is fine-tuned to optimize the antenna performance at different frequencies, modulation schemes and modes of operation (hands-free, slide open, closed etc.). This configuration is stored in a look-up table in the non-volatile memory of the handset at the time of production. Based on the information provided by the higher layer software, the tuning algorithm selects the appropriate setting for the matching network. However, this mechanism is not able to adapt according to the changing environment conditions since it does not make any real time measurement. The usage of a mobile device has a constantly changing environment as the user walks, drives, moves his or her fingers (commonly referred to as head or hand effect). So the open loop approach is not as effective in restoring the losses caused by impedance mismatch.

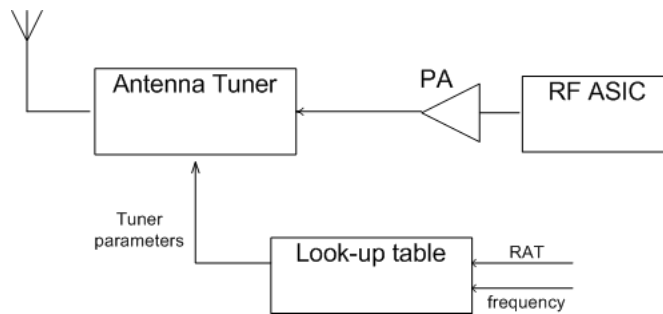

Figure 3: Block diagram of Open Loop antenna tuning

The Closed Loop or adaptive antenna tuning method [4] on the other hand consists of three primary components as shown in Figure 4.

- An adjustable matching network called antenna tuner that can produce the required impedance.
- A mismatch sensor or detector [5] and an analysis unit. The detector is usually realized by a bidirectional coupler. The analysis unit is a module that measures in real time the forward and reflected wave and provides the reflection coefficient.
- A tuning algorithm that executes in the micro-controller and compares the actual value with the desired set point and computes the new settings for configuring the matching network.

Thus this mechanism acts as a feedback system by configuring the components of the matching network in order to achieve the optimum impedance match hence adaptively forcing the antenna impedance to appear 50 ohms in spite of the environmental effects. Although the antenna tuner introduces some insertion loss in the setup, the overall improvement in performance, offsets this loss.

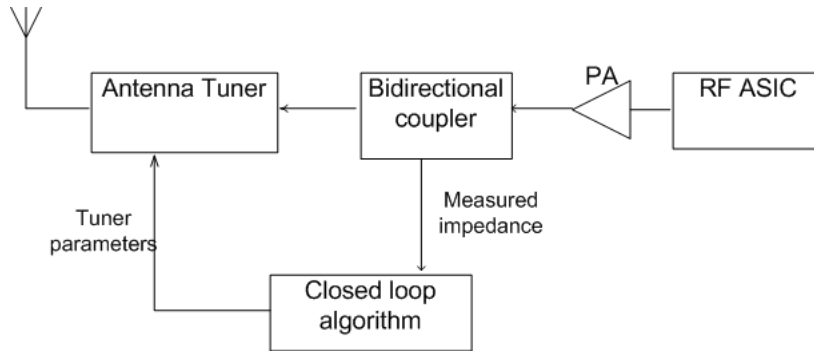

Figure 4: Block diagram of Closed Loop antenna tuning

### 1.1.3 Impedance Tuner

The impedance matching or antenna tuning network usually comprises of passive components like capacitors and inductors connected in serial or parallel topology. Antenna impedance tuner technology has not yet been introduced commercially on a large scale in cellular terminals. One of the major reasons behind this has been the absence of electronically tunable reactive components that are able to deliver high performance in terms of low insertion loss, power handling range, linearity and wide tuning ratio. Advances in the microwave and millimeter wave technologies in the last two decades have enabled the fabrication of passive components monolithically or on a system-on-chip, delivering high performance and low cost systems. However, creating adjustable or tunable matching networks that have a low insertion loss, and can support a wide range of power and frequency, still continues to be a subject of research. Some of available technologies available for developing the tunable matching networks are as follows:

- MEMS (Micro-electro-mechanical systems) [6] [7]: Using MEMS technology, a capacitor can be tuned by changing the separation space between its two metallic plates. One of the plates is fixed while the position of the other plate is adjusted to achieve the required value of capacitance.
- BST (Barium Strontium Titanate) [8]: BST technology uses thin-film ferroelectric materials whose dielectric constant can be changed by applying high voltage DC-bias thus changing the capacitance.
- DTC (Digitally Tunable Capacitors) [9]: This technology uses variable capacitors where circuit design is determined by digital control signals.

## 1.2 Objective and goals

This thesis aims at designing and developing an antenna impedance tuner system that can be introduced at commercial scale in cellular terminals. The broad level goals are as follows:

- The antenna tuner shall improve over the air performance (total radiated power/total isotropic sensitivity).
- The antenna tuner shall decrease the VSWR seen by the power amplifier output while improving the efficiency and the overall current consumption.
- The antenna tuner shall not influence the complex baseband signal in a way that the signal processing algorithms are disturbed significantly.
- The antenna impedance tuner algorithm shall prioritize closed loop, and shall transfer to open loop when closed loop is not feasible. The algorithm shall adapt to the transmitted power and the interference power level.

Besides the above goals, the intention is to keep the system as flexible as possible so that there is minimum dependence on the topology and technology used in the antenna tuner and adaptation to a different tuner can be easily done. This is required because the supplier of antenna tuner hardware is not the same as that of RF transceiver hence the choice is most probably made by the mobile handset manufacturer.

In order to achieve the goals set for the performance and design of antenna tuner system, this thesis aims to implement the following modules:

- Reflection coefficient tracking module that characterizes the measurement receiver and sets it up with correct parameters so that the magnitude and phase of forward and reflected power can be measured.
- Tuning algorithm that determines the extent of impedance mismatch and calculates the new settings of antenna tuner to mitigate the mismatch.
- Antenna tuner control module that programs the MIPI RF front end bus to make appropriate settings to the antenna tuner hardware
- Common control module that controls the state machine of the antenna tuning system on the basis of the power level, measurement results of the measurement receiver and various other factors.

Thereafter measurements will be done in the laboratory where the mismatch conditions of the antenna will be simulated with lab equipment and the performance of the tuner system, with respect to the RF parameters will be observed and recorded.

### 1.3 Outline

The rest of the thesis is organized as follows. Chapter 2 presents the basic theoretical concepts of impedance matching in generic electrical circuits and the measurement parameters that are used in this subject. The building blocks, both hardware and software, of a generic antenna impedance tuner are also described in this chapter. Chapter 3 gives a detailed design of the various modules of the antenna tuner system that are developed as part of this thesis work including a few algorithms for

impedance tuning that were designed and evaluated during the course of the project. The timing considerations involved in implementation of antenna tuning system for different RATs are also treated here. Also the performance parameters that play a key role in evaluating the performance of a tuning system are mentioned in this chapter. Chapter 4 describes the test and measurement system used in the laboratory and presents the measurement results. Thereafter the results are analyzed to check whether and how an antenna tuning system can be a viable solution for a commercial handset. Chapter 5 concludes with a summary and recommendations for future research work.

## 2 Background

The concept of antenna impedance tuning is not new in the wireless communications world [10]. The traditional approach followed by the antenna designers is to use extensive simulations and fine tune the antenna after spending long hours of measurements in the lab. Needless to say this consumes a lot of time, effort and resources. As the requirement of frequency range to be supported by the antenna grows larger and the design constraints become higher, this approach is becoming untenable. Besides, this methodology gives static results that cannot adapt to the changes in the antenna environment. Hence, the concept of closed loop adaptive antenna tuning is gathering momentum and most of the mobile phone manufacturers are exploring the possibility of including some form of antenna tuning in their handsets. Before delving deeper into the design and implementation of such a system, it is important to treat the fundamental concepts behind antenna design and impedance matching.

This chapter presents the theoretical background on the subject as well as an introduction to the building blocks involved in developing a practically realizable antenna tuning system.

### 2.1 Theory

Matching the impedance of the antenna to the ideal impedance of 50 ohms is one of the solutions to avoid the consequences of the mismatch. This section presents the basic theory and mathematical details behind the concept of impedance matching. The parameters which can measure the quality of match, are also listed.

#### 2.1.1 Impedance matching

Impedance matching can be defined as the task of matching the input impedance of one circuit or device (source) to the output impedance of another (load) when both are connected together. The motivation for impedance comes from the fact that maximum power transfer through the two devices can take place when their impedance are matched else a large percentage of input power gets reflected. When both the load and the source are purely resistive then according to the Maximum Power Transfer Theorem, the load resistance must be equal to that of the source for optimal power transfer. In case the circuit consists of reactive elements, a conjugate match between the load and the source is needed for maximum power transfer. In most of the cases, it is not possible to change the configuration and design of either of the two devices in order to improve the impedance match. Hence a common solution is to connect another device in between whose configuration can be controlled or tuned. Such a device is called the impedance matching network. However, it is important that such a network should not introduce a significant insertion loss and must deliver a reasonably good performance over a wide range of frequencies.

The main task of the matching network is to force the load impedance to look like the complex conjugate of the source impedance in order to ensure maximum

transfer of power to the load. For example let us consider a two port network shown in Figure 5 .

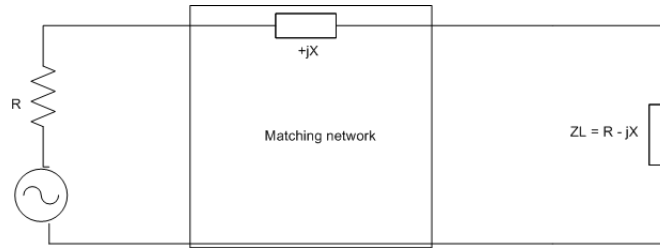

Figure 5: Impedance matching

For maximum power dissipation,  $R_S$  should be equal to  $R_L$  and the net reactance must be zero. This occurs when the load and source are such that they have the same real parts (resistance) and opposite type imaginary parts (reactance). So if the source impedance  $Z_S = R + jX$ , the load impedance in a perfectly matched circuit will be the complex conjugate of  $Z_S$  i.e.  $Z_L = R - jX$ . If the resistive parts are equal and the reactive part of load impedance is series inductance then the reactive part of matching network can be series capacitance and vice versa. There are two issues that make this simple concept rather challenging to implement:

- Perfect conjugate match obtained at one frequency is not good at another frequency due to the variation in reactive values with the frequency.
- The matching process is quite complicated when resistive parts are not equal or when both the source and load have complex impedance.

### 2.1.2 LC Impedance Matching Networks

Using inductors and capacitors in series or parallel in an impedance matching network is quite common primarily because these passive elements do not consume power and do not add any noise to the circuit. Any two resistive terminations can be matched by introducing two reactive components in between them in the form of a matching network [11]. Figure 6, 7, 8 and 9 show four possible single section LC matching networks where (a) and (b) are low pass type while (c) and (d) are high pass type impedance matching networks. Parallel or Shunt reactance is always placed on the side of the higher impedance. Depending on the bandwidth requirements and the size of the load and source impedances, a suitable configuration can be chosen.

The quality of such L-C circuits is quantified in terms of Q (Quality factor). For a single reactive device, Q is defined as the ratio of the stored power to the dissipated power. It is a dimensionless quantity and is expressed as a function of reactance X and resistance R.

$$Q = \frac{X}{R} \quad (1)$$

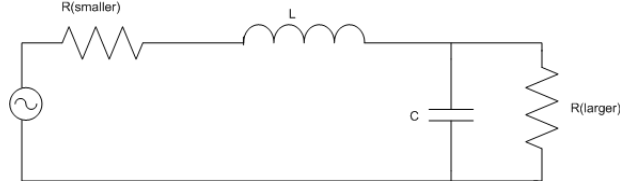

Figure 6: LC circuit (a)

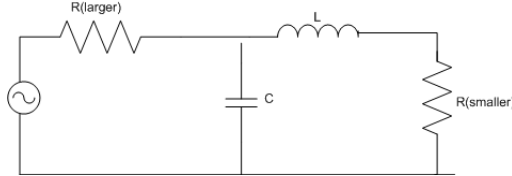

Figure 7: LC circuit (b)

$Q$  has an inverse relationship with the bandwidth or operational range of frequencies for an LC circuit. For a complete L-C circuit with a load  $R_L$  and a source  $R_S$ , quality is quantified in terms of Loaded Quality Factor ( $Q_L$ ).  $Q_L$  is defined as the ratio of magnitude of the total reactance to the total resistance of the circuit.

$$Q_L = \frac{X_1}{R_S} = \frac{R_L}{X_2} \quad (2)$$

$X_1$  stands for series matching reactance while  $X_2$  stands for shunt matching reactance. Both elements can be capacitors or inductors. The following equations show how the values of passive components in the matching network can be chosen provided the source and the load impedances are known.

$$Q_L = \sqrt{\frac{R_L}{R_S} - 1} \quad (3)$$

$$X_1 = Q_L * R_S \quad (4)$$

$$X_2 = \frac{R_L}{Q_L} \quad (5)$$

The problem with the above LC networks is that they can either match a smaller impedance to higher or vice versa. If the load impedance changes such that the earlier assumption about it being lower or higher than the source impedance is not

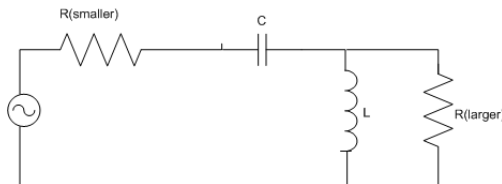

Figure 8: LC circuit (c)

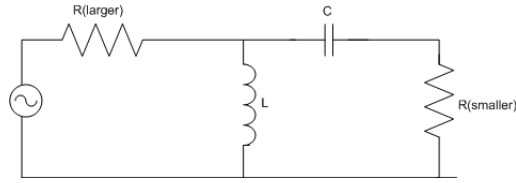

Figure 9: LC circuit (d)

valid anymore, then a match cannot be obtained without changing the topology of the matching circuit. By adding another section to the single section LC network, this problem can be resolved. Two such typically used configurations for LC matching networks are the Pi-network (Figure 10) and the T-network (Figure 11). These configurations allow three degrees of freedom in the form of three tunable reactive components to achieve an impedance match between load and source. The disadvantage of such networks is that the matching algorithm becomes substantially complex.

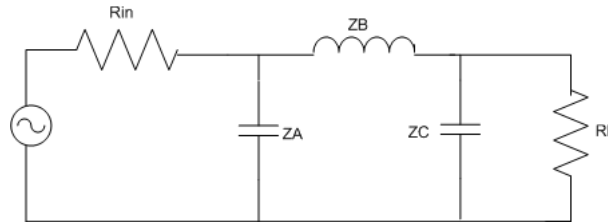

Figure 10: Pi-network

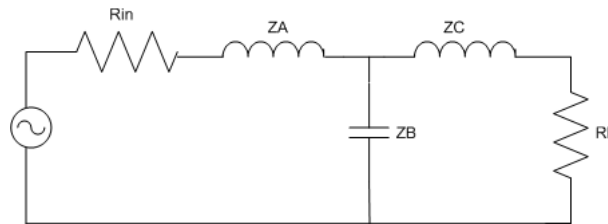

Figure 11: T-network

The following equations and Figure 12 show the arithmetic that needs to be solved for a Pi-network to determine the load impedance assuming that the source impedance and the current values of the three reactive components is known.  $Z_B$  stands for the impedance of the series component while  $Y_A$  and  $Y_C$  stand for admittance of the shunt components.

$$Y_1 = \frac{1}{Z_{in}} - jY_C \quad (6)$$

$$Z_2 = \frac{1}{Y_1} - jZ_B \quad (7)$$

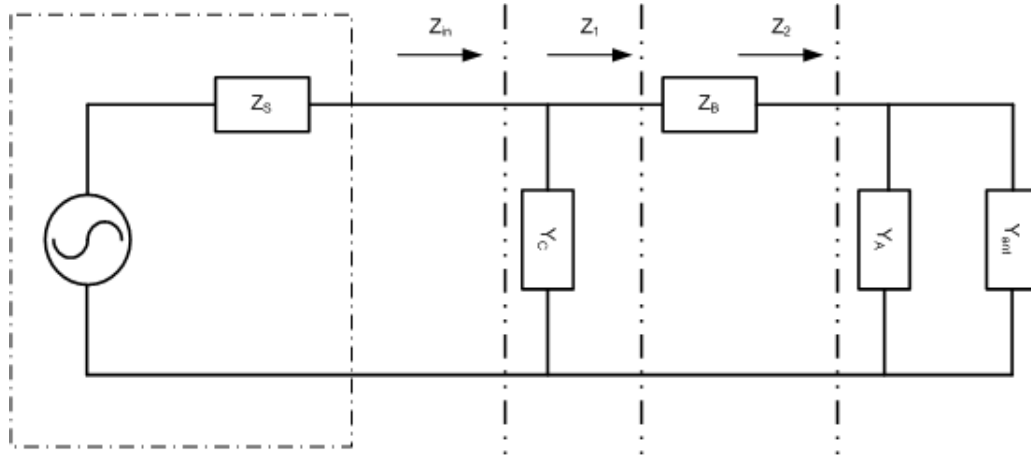

Figure 12: Equivalent diagram of Pi-network

$$Y_{ant} = \frac{1}{Z_2} - jY_A \quad (8)$$

After the load or antenna impedance is calculated using equations 6, 7 and 8, the values of the three tunable reactive components has to be estimated for a perfect match between the source and the load. One approach to simplify the estimation process is to divide the Pi-network into two LC networks and match the load and source impedance to a common intermediate resistance. Such matching networks are not clearly determinable. There is always more than one solution depending on the choice of the intermediate resistance which in turn determines the value of the loaded quality factor and thus the bandwidth of the matching.

### 2.1.3 Binary capacitance array

Implementing variable capacitance and inductance as integrated components is, in practice, not an easy task. Few technologies are available (mentioned in section 1.1.3) but are expensive hence the cost of the component can make the use of antenna tuner less attractive. A cheaper and easy to implement alternative is to use a switched array of fixed value capacitances [12] [13]. The effective capacitance of the circuit comprises of a set of capacitors organized as a set of binary weighted parallel capacitance values, controlled by switches to engage or disengage each capacitor from the reactive element to increase or decrease the resulting capacitance. Figure 13 shows such a circuit. Depending in the number of capacitances used, discrete steps of impedance values can be achieved using this kind of circuit. However, the range of impedance and the accuracy of match is limited. In addition the layout parasitics of the capacitors (depicted by  $C_p$  in the Figure 13) further limit the tuning resolution of the capacitor array. Nevertheless the cost and ease of implementation factors still make this kind of matching network an option to consider.

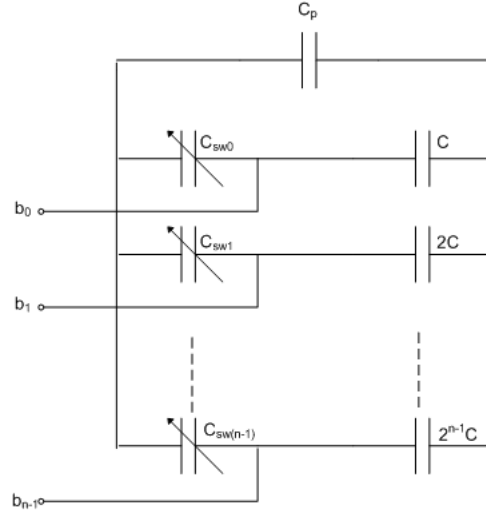

Figure 13: Binary weighted capacitance array

### 2.1.4 Measuring parameters

Quality of impedance match can be characterized in terms of parameters like Reflection Coefficient, Scattering matrix and Voltage Standing Wave Ratio (VSWR). A brief description of each of these parameters is given below.

Scattering matrix: Scattering matrix is a way of describing the behavior of voltage and current travelling through a transmission line when they come across an impedance differing from the line's characteristic impedance. Also known as S-parameters matrix, it is a square matrix of unit-less complex numbers. For the purpose of this thesis work, an S matrix for a 2 port network as shown in Figure 14 is considered.

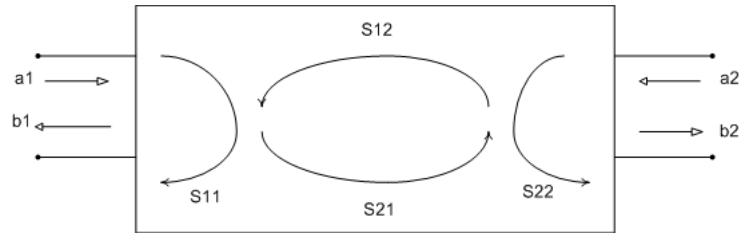

Figure 14: S parameters in a two port network

The variables  $a_1$  and  $a_2$  represent incident voltages while  $b_1$  and  $b_2$  stand for reflected voltages. The S matrix for such a model is given by:

$$\begin{pmatrix} b_1 \\ b_2 \end{pmatrix} = \begin{pmatrix} S_{11} & S_{12} \\ S_{21} & S_{22} \end{pmatrix} \times \begin{pmatrix} a_1 \\ a_2 \end{pmatrix}$$

Each element of the matrix is a ratio between forwarded and reflected voltages at the respective ports as described below.

$$S_{11} = \frac{b_1}{a_1} \Big|_{a_2=0} \quad S_{12} = \frac{b_1}{a_2} \Big|_{a_1=0} \quad S_{21} = \frac{b_2}{a_1} \Big|_{a_2=0} \quad S_{22} = \frac{b_2}{a_2} \Big|_{a_1=0} \quad (9)$$

Hence  $S_{11}$  is defined as ratio of the reflected voltage at port 1 and the input voltage at the same port where the output port is terminated by a matched load i.e.  $a_2$  is equal to 0.  $S_{11}$  is the most important S parameter in our calculations and is also referred to as reflection coefficient.

Reflection coefficient  $\Gamma$ : When applied to a transmission line model, reflection coefficient is expressed in terms of load and source impedance. Value of reflection coefficient ranges from -1 to +1 depending on if the load impedance is 0 (short) or infinity (open) respectively. In a situation of perfect match when load impedance equals source impedance, there is no reflection along the transmission line and reflection coefficient is 0.

$$\Gamma = \frac{Z_L - Z_S}{Z_L + Z_S} \quad (10)$$

VSWR: When an antenna is not matched to the receiver, power is reflected from its terminals. This reflected voltage leads to the creation of a standing voltage wave that has maximas and minimas along the transmission line. VSWR is defined as the ratio of the peak amplitude of this standing wave to the minimum amplitude. Hence VSWR is a measure of how much power supplied to the antenna is reflected back from it. Mathematically, VSWR is expressed in terms of reflection coefficient  $\Gamma$ .

$$\text{VSWR} = \frac{1 + |\Gamma|}{1 - |\Gamma|} \quad (11)$$

VSWR is a unit-less ratio and is always a real and positive number. The smaller the VSWR, the better is the impedance match between the antenna and the radio transceiver and the lesser is the power loss. Ideally the value of VSWR should be 1.0 in a situation where all the power is delivered to the antenna and none is reflected. The wide range of supported bandwidth and the environment conditions make it almost impossible to achieve this ideal scenario hence a somewhat higher value is usually acceptable. However as the VSWR increases, more power is reflected from the antenna. Table 1 shows the physical significance of different values of VSWR in terms of actual reflected power.

Smith chart: The value of reflection coefficient can be expressed graphically in a complex plane such that both the real (resistance) and the imaginary (reactance) values are shown in the form of circles. Such a plot of circles is called the Smith chart as shown in Figure 15. The horizontal axis represents pure resistance with 0 at far left and infinity at far right. The center point is where the reflection coefficient is 0 and hence the impedance is ideal 50 ohms. Circles on the Smith chart represent constant resistance curves, while the arcs radiating out from the right side to the edge of the Smith chart represent reactance curves. The points above the real axis represent inductive circuits while the ones below represent capacitive circuits.

Table 1: VSWR, s11 and reflected power

VSWR	S11	Reflected power(%)	Reflected power(dB)
1.0	0.000	0.00	-Infinity
1.5	0.200	4.0	-14.0
2.0	0.333	11.1	-9.55
2.5	0.429	18.4	-7.36
3.0	0.500	25.0	-6.00
3.5	0.556	30.9	-5.10
4.0	0.600	36.0	-4.44
5.0	0.667	44.0	-4.02
6.0	0.714	51.0	-2.92
7.0	0.750	56.3	-2.50
8.0	0.778	60.5	-2.18
9.0	0.800	64.0	-1.94
10.0	0.818	66.9	-1.74
15.0	0.875	76.6	-1.16
20.0	0.905	81.9	-0.87
50.0	0.961	92.3	-0.35

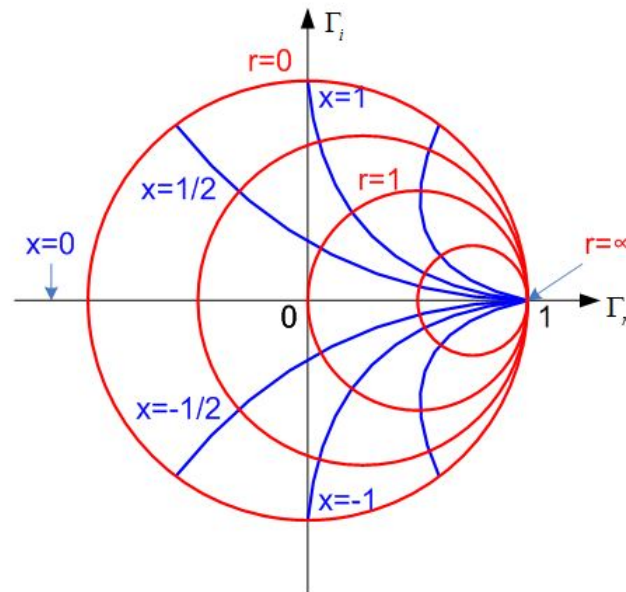

Figure 15: Smith Chart

## 2.2 Antenna Fundamentals

Antenna is the integral and the most essential part of any wireless product. It can be described as a transducer that converts electromagnetic energy to radiating waves in free space and vice versa or as a band pass filter that operates in a defined band of frequencies while rejecting all other frequencies. Performance of a wireless

device depends to a large extent on the robustness and the design of its antenna. An expensive and compact radio module can easily lose its benefits because of bad design or improper integration of the antenna. This section takes a brief look on the fundamental concepts [14] involved in antenna design, various types of antenna and their performance characteristics.

### 2.2.1 Antenna Characteristics

Performance of antennas can be characterized by the following metrics:

- Input Impedance: Input Impedance is the ratio between voltage and current at the antenna port. It is a complex quantity and it changes with frequency. It is expressed in terms of VSWR and return loss and is plotted on a Smith Chart. These parameters measure how much power that is supplied to the antenna reflects back from its terminals. In transmission this power is reflected back to the power amplifier while in reception it is reflected back to the antenna. For an acceptable transmission of power between the antenna and free space, it is essential that the input impedance of the antenna has an acceptable value for a range of frequencies. In cellular terminals a VSWR of 1.5 is considered to be good while a value up to 2.0 is acceptable.
- Efficiency: Efficiency of an antenna is a measure of the percentage of applied power that the antenna is able to radiate. It is defined as the ratio of radiated power to the input power as shown in the following equation.

$$e = \frac{P_r}{P_{in}} \quad (12)$$

The portion of applied power that is not radiated is lost due to different reasons. Part of it can be reflected due to impedance mismatch while part is lost due to absorption by nearby grounded conductors or dielectric materials. The design constraints of modern handsets where antennas are embedded and surrounded in plastic casings, can significantly effect the radiation efficiency of the antenna. On an average the antenna efficiency is between 40 to 75% where more than 75% is difficult to achieve with embedded antennas and less than 40% is rejected during certification.

- Polarization: Polarization of an antenna is the orientation of its electric field with respect to the Earth's surface. It is determined by the physical structure and orientation of the antenna. For two antennas communicating in Line Of Sight, it is extremely important that they are polarized in the same orientation for efficient transfer of energy. However in the real world of mobile communications, the Line of Sight rarely exists. Also the radio wave experiences reflection and scattering from the atmosphere and from the objects in the path which substantially changes its radiation pattern and polarization. In addition the usage of a mobile terminal is such that it is used in varying orientations. Hence any optimization done for antenna polarization in mobile terminal design is not very useful.

- Linearity: In ideal conditions antenna can be considered a passive linear device. But when faced with high input power and multiple frequencies, the metal joints and non-linear materials used in the antenna structure lead to the generation of intermodulation products with frequencies different from that of the input signal [15, Chapter 1]. When these intermodulated signals are reflected back from the antenna, they interfere with the receiver. If the receiver is highly sensitive, these signals can cause substantial interference. In mobile terminals this problem is not that serious since the input power is generally kept low to preserve battery life but in base stations where the input power is high, receiver sensitivity is very low and multiple frequency signals are commonly transmitted from the antenna, it is important to take care that the generated intermodulated signals are kept at a sufficiently low level.

### 2.2.2 Antenna types

Antennas used in wireless devices are either external or embedded inside the device. An external antenna is connected to the device on one end while the other end is in free space generally perpendicular to the device. There are several advantages associated with this kind of construction. The efficiency of such antennas is higher and their distance from the digital noise sources present inside the device, ensures better performance. However their susceptibility to damage and the design constraints of modern wireless products have almost completely eliminated their use. Nowadays most antennas are embedded inside the mobile device. Two commonly used embedded antennas, Inverted-F and Microstrip patch, are discussed here.

- Planar Inverted-F style antenna (PIFA): A basic PIFA antenna is a quarter-wave long conductor in the form of a metal plate, a few millimeters above the ground plane, fed by a 50 ohm feedpoint at one end and grounded by DC shorting plate on the other end. The input impedance of a PIFA antenna is controlled by changing the distance between the shorting plate and the feeding point while the height of the plate above the ground plane is fixed. The range of supported resonant frequencies depends on the dimensions of the PIFA antenna. Due to their low cost, easy fabrication, high bandwidth and efficiency, PIFA antennas are nowadays the most popular antennas used in wireless devices. They are usually omni-directional i.e. they do not radiate in a particular direction.
- Microstrip patch antenna: Microstrip patch antennas are usually in the form of a one half wavelength long rectangular structure, fed by a microstrip transmission line, held over a ground plane made of highly conductive material, separated by a dielectric material of only a few millimeter thickness. The distance between the patch antenna and the ground plane can be much less than that of PIFA antenna. The bandwidth and input impedance of such an antenna depends on the dielectric constant of the substrate and the width of the antenna. The electric field of microstrip patch antenna is linearly polarized and its directivity is usually between 5-7 dB. Due to the directive nature and

surface area requirement, these antennas are not commonly used in mobile devices but they are very useful in fixed or mounted devices that radiate in a particular direction.

### 2.2.3 Design issues

An antenna cannot be characterized in isolation since the complete reference design of the radio module as well as the front end components, determine the input impedance and the efficiency of the antenna. Hence picking up an off the shelf antenna with certain desired characteristics, when used with a pre designed radio system, may not necessarily give the expected results. Some of the design issues encountered when designing the front end of a radio system are presented here in brief.

- Connection with the front end components: The front end of a radio system is comprised of power amplifiers, filters, switches and their connections between the radio module and the antenna. When measured in isolation, each of these components might be well matched to each other and to the antenna termination but when interconnect cables and PCB traces come into play, the impedance matching scenario can change completely. This impedance mismatch detunes the antenna, distorts the filter response and effects the linearity of the power amplifier.
- Self-interference: Improper shielding or the placement of antenna too close to the digital noise source (processors, clocks, memory etc.), leads to various spurious emissions from the device’s own digital circuitry or from the reflected signals to enter the antenna and other front end components, thus raising their noise floor and reducing the sensitivity of the radio module.
- Coexistence with other wireless technologies: Modern wireless handsets provide multiple radio technologies like Wi-Fi, Bluetooth, GPS etc. that have radio transceivers and antennas operating over a varied frequency range. If enough attention is not paid during the design phase, these antennas might be quite close to one another interfering with each other and with the cellular reception. Hence it is important both in the design and the characterization phase, to test the radio system with other radio technologies.

## 2.3 Building Blocks

Nowadays, many players have come up in the market promoting different technologies and solutions for antenna tuning. After considering the pros and cons of different solutions, it was decided in ST-Ericsson to use the antenna tuner part by STM-Paratek, for developing the first phase of this antenna tuning system. However, the system design will be done considering that there will be customer requests for other suppliers in the future so that a suitable robust system structure is chosen. This means that the implementation details of the antenna impedance tuner shall be well separated and easily identifiable in the antenna tuner system.

Many of the hardware components used in developing this system, are already part of the current modem and RF sub-system project under progress in ST-Ericsson. The only missing element that needs to be added in this already existing set-up is antenna impedance tuner. The antenna impedance tuners are controlled via the MIPI RF Front End Interface (MIPI RFFE IF), which is shared with the other front end components in the radio subsystem.

The software with the antenna tuner algorithm is to be executed on the CPU already residing inside the RF sub-system, the STxP70. The drivers for the measurement receiver and the MIPI RFFE IF are also created as part of this thesis work to support the antenna tuner algorithm. The antenna tuner algorithm needs to interact with the transmitter power control algorithm in order to function properly, but the antenna tuner algorithm is besides from that modular and can be removed from the other radio control software.

### 2.3.1 Adaptive Antenna Tuner

The electronic circuit of an impedance tuner is usually in the form of a T-network or Pi-network with tunable capacitances and/or inductors. By varying the value of these tunable components, impedance is changed and hence a near perfect match can be achieved for different frequencies. The number of tunable elements is limited to three in this project. This limit is chosen since the antenna tuner algorithm becomes substantially more difficult if a larger number of tunable components are allowed. The insertion loss of the antenna impedance tuner also scales with the number of tunable components. Figure 16 shows the circuit diagram of the STM-Paratek tuner that is used in this project for adaptive antenna tuning. This tuner consists of a Pi-network of three fixed inductors and three Positive Temperature Coefficient (PTC) tunable capacitors. The electrical characteristics of PTC capacitors is such that there is very little effect of temperature variation on the performance of the circuit.

The STM-Paratek tuner uses the technology of BST capacitors. BST capacitors are based on thin-film ferro-electric materials that are known for providing high Quality factor and low leakage current. On applying high voltage (approximately 20V) DC bias to such materials, their dielectric constants are changed and so does the capacitance. These high voltage settings become the tuning or control signals for the tuner. In STM-Paratek tuner, the high tuning voltage is applied from separate components called HVDACs (High Voltage Digital to Analog Converters). Each capacitor has a separate bias voltage provided by an HVDAC. The DAC setting is 8 bit long and determines the bias voltage level. The HVDACs are controlled by the antenna tuner algorithm via the MIPI RFFE IF from the radio module.

### 2.3.2 Bidirectional Coupler

The antenna tuner system includes a bidirectional coupler[16] to sense the transmitted signal and the signal reflected at the antenna. Directional couplers are RF passive devices that can act as power sensors due to their ability to couple a specific proportion of the power travelling in one transmission line out through another

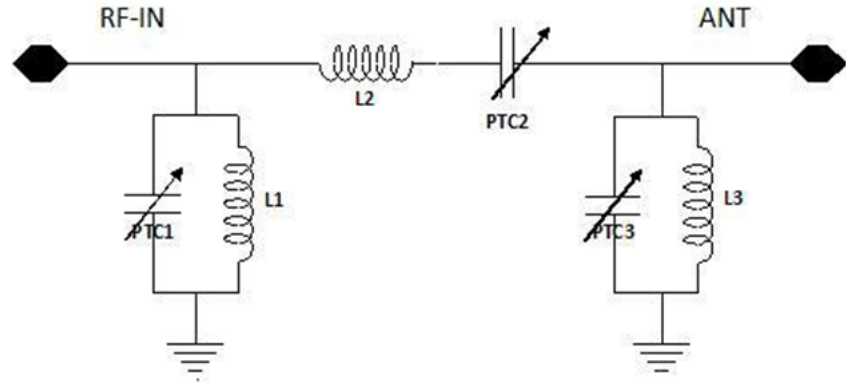

Figure 16: Circuit diagram of STM-Paratek adaptive antenna tuner

connection or port. A directional coupler is typically a four port device as shown in Figure 17. The ports are:

- Port 1 - Input port
- Port 2 - Output or Transmitted port
- Port 3 - Coupled port
- Port 4 - Isolated port

The power supplied to Input port is coupled to the Coupled port and also delivered to the Output port. In an ideal directional coupler, no power is delivered to the Isolated port. Directional couplers are characterized by the following parameters:

- Coupling: This is the amount of incident power that is lost to the Coupled port. It is defined as the ratio between the power at the Input Port to the power at the Coupled port.
- Directivity: This is the difference of power levels between Coupled and Isolated ports. It is the measure of directional coupler's ability to isolate forward and backward waves and is the most important indicator of the accuracy of the measured power levels. High directivity ensures better accuracy.
- Isolation: This is the amount of incident power lost to the Isolated port. Ideally this value should be zero but there is always come power that leaks to the Isolated port due to imperfect isolation.

This coupler is integrated into the front end module of the RF sub-system. A lot of care is needed to ensure proper isolation between forward and reflected signal tracks. Power leakage from the transmitted signal to the reflected signal and vice versa is always a potential source of errors and inaccurate measurement.

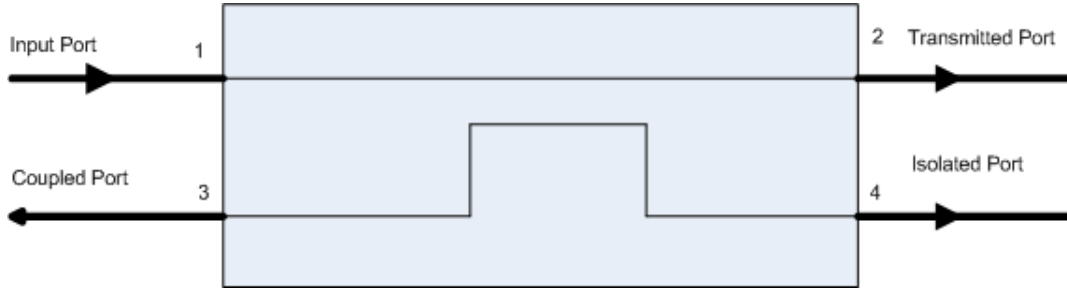

Figure 17: Directional Coupler

### 2.3.3 Measurement Receiver

The measurement receiver is a radio receiver that samples the acquired transmitter signal (from the bidirectional coupler) and compares it with a reference signal. From the comparison, the measurement receiver calculates the phase and the gain of the acquired signal. It is a part of the radio transceiver and is also used in closed loop power control. It has a single-ended RF input which can be switched between two separate input pins, one input for sensing the forward transmitter signal and the other for sensing the reflected transmitter signal. The input signal is then passed through an attenuator that has a 24dB control range with 6dB control steps. It is then down-converted to the baseband and the resulting I and Q signals are passed through a baseband gain block that can also be controlled till 24dB in steps of 6dB. The down-converted baseband signal is passed through a low pass filter to reduce the level of interference. The filter bandwidth is adjustable and it defines the noise bandwidth of the measurement receiver. The filtered signal is then fed to a 10 bit Analog to Digital converter (ADC) and then finally to the digital front end. The digital block has the algorithms to calculate the Root Mean Square (RMS) level and the phase of the detected signal. The block diagram of the measurement receiver given in Figure 18 shows its various components clearly.

### 2.3.4 MIPI RFFE interface

The HVDACs of antenna impedance tuner are fully controlled through the RFFE serial interface (DATA, CLOCK, VIO) which is compliant with the MIPI alliance specification for RF front end control interface[17]. The configuration of MIPI RFFE IF used in this project operates at 26 MHz where the radio transceiver is the master. The slave i.e. Antenna tuner is not capable of making any requests to the master. This interface is shared with the other front end components in the radio subsystem such as power amplifier and antenna switch. The system also has a 2nd MIPI RFFE IF which optionally can be used as a dedicated interface to control the antenna impedance tuners.

In order to meet the precise timing requirements and to avoid RFFE interface traffic congestion at critical moments, a trigger mode is used to control the HVDACs. The trigger mode, enabled by default, works such that the register values, containing the settings for HVDACs are stored temporarily in shadow registers. When the

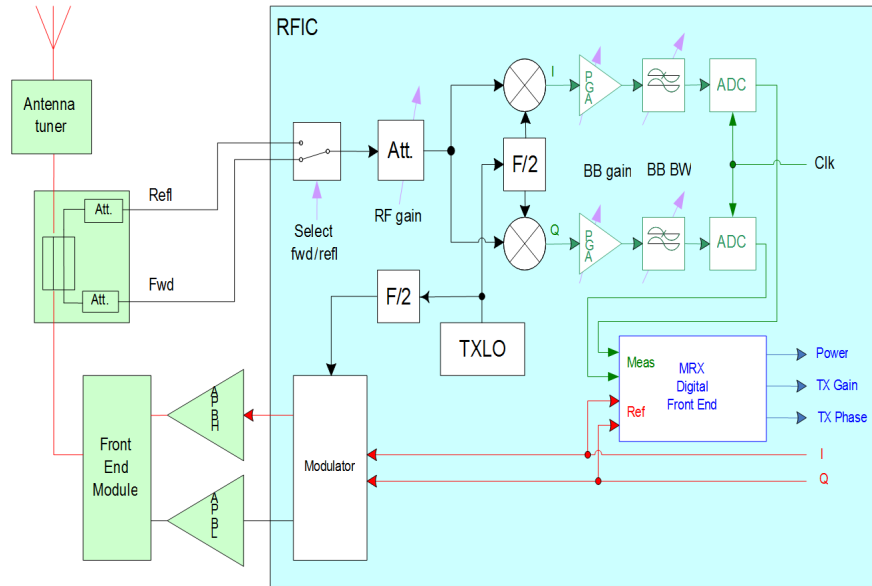

Figure 18: Measurement receiver block diagram

trigger is set, the shadow registers are loaded into destination registers and the new DAC values come into effect.

### 2.3.5 Processors

The radio transceiver used in this thesis work has two processors, an RF sequencer and a STxP70 CPU. The STxP70 is a 32-bit Reduced Instruction Set Computer (RISC) based multi-threaded CPU that has separate bus and memory for data and code. The CPU executes all high level commands and interface control commands that are not handled directly in the hardware. The commands are either executed directly in the CPU or it prepares the RF Sequencer (RFS) for the command execution. The RFS is a simple processor that allows simple programs with sequences and branches. It is able to perform some arithmetic and bit manipulation commands. The RFS provides three independent threads that are processed in a round robin manner. It is mainly used to control all radio sequence activities that are time critical and hence are triggered by specific RF timers. Most of the software modules and algorithms that are developed as part of this project, are loaded and executed in the CPU. However, since the RFS is responsible for the modules that are to be executed at certain time instants in the data and control transmission sequence, the code for measuring forward and reflected power from the measurement receiver is executed in RFS.

### 2.3.6 Software

The antenna tuning software can be divided into four logical parts:

- Reflection coefficient tracking: This part of the software deals with configuring the measurement receiver, reading the values of forward and reflected trans-

mitter powers and then calculating the corresponding reflection coefficient and S11.

- Impedance calculation algorithm: This part uses the S11 and reflection coefficient measurement results to calculate the new impedance values (and HVDAC settings) for a better match as per the antenna impedance tuner topology.
- Common algorithm control: This is the central controlling block of antenna tuning software that determines whether the impedance calculation algorithm works in open or closed loop depending on the antenna condition, accuracy of the reflection coefficient measurements and other settings.
- MIPI RFFE driver: The task of this driver is to control the HVDAC values in the antenna tuner by programming the MIPI RFFE interface.

The implementation details of all the above blocks are explained in the subsequent sections.

### 3 Design and implementation concept

The antenna tuner system is an optional part of the radio sub-system. There is no remaining cost penalty or PCB area penalty if the antenna tuner system is removed. In order to achieve this, the antenna impedance tuners and the associated circuits are situated outside the standardized PCB layout for the radio sub-system. The antenna tuner system needs support also from outside the radio sub-system. Information about antenna conditions comes from outside the modem, i.e. the application part of the mobile phone.

The architecture of antenna tuner system is designed such that there is a central control block that has the intelligence to control all the sub-modules that encapsulate the functionality of dedicated peripheral hardware components. These modules can be easily replaced or modified when the corresponding hardware is changed. Coexistence with other control algorithms that use the same hardware block is also taken care inside the respective sub-module. Figure 19 shows the architecture block diagram of the antenna tuner sub-system. Each element of this architecture is described in detail in this section.

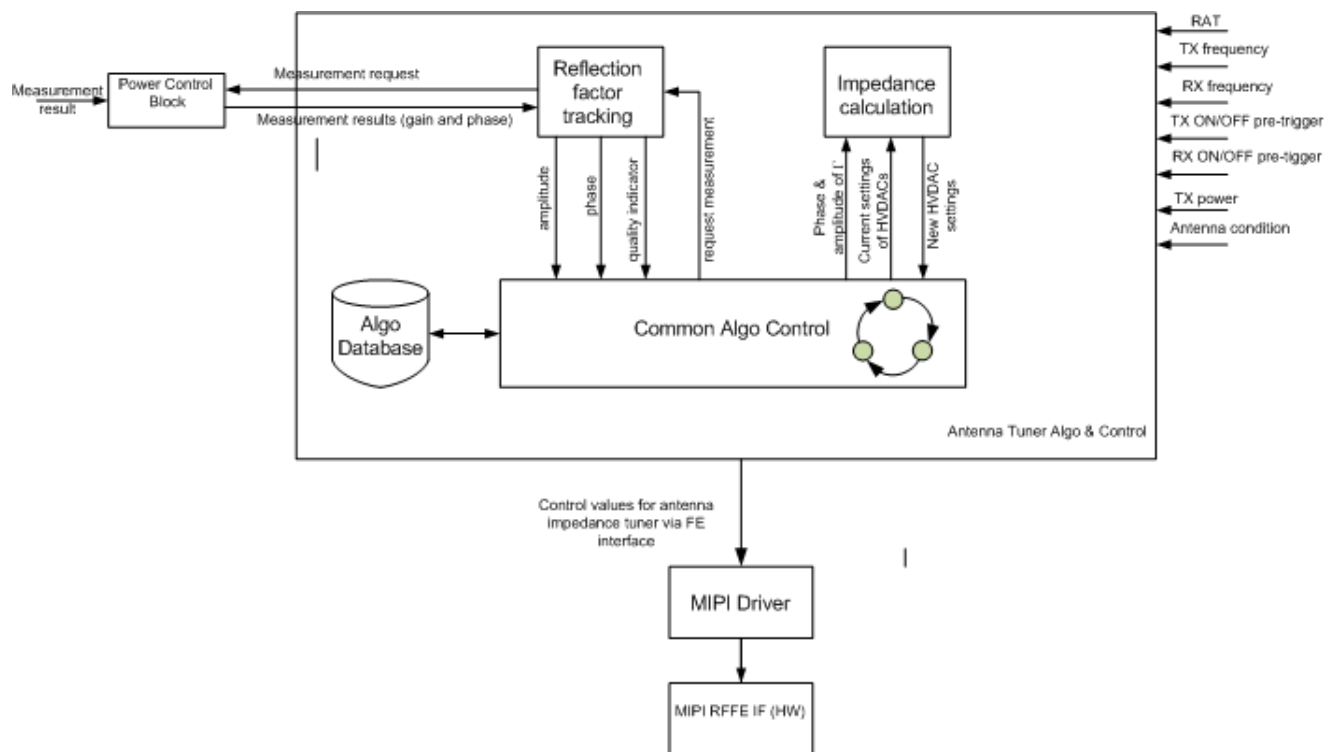

Figure 19: Architecture block diagram

#### 3.1 Reflection coefficient tracking

The task of this module is the detection and analysis of antenna mismatch. A measure of antenna mismatch is the complex reflection coefficient which has an

amplitude and a phase. Hence this tracking module triggers the measurement of reflection coefficient from the measurement receiver. The hardware details of measurement receiver are explained in section 2.3.3. Before the measurement is triggered, a sequence of register writes are done by this module for setting the filter bandwidth, RF, baseband and digital gain blocks, measurement direction and operational frequency band in order to initialize and prepare the different hardware blocks inside the measurement receiver. The measurement receiver in practice does not return the amplitude and phase of the reflection coefficient but the power and phase of the forward and reflected signal. It is the task of this module to calculate the amplitude and phase of reflection coefficient from these parameters. The following equations show how the derivation is done.

$$\text{Amplitude}_R[\text{dB}] = a * (\text{Amplitude}_{\text{rev}}[\text{dBm}] - \text{Amplitude}_{\text{fwd}}[\text{dBm}]) + b \quad (13)$$

$$\text{Phase}_R[\text{degree}] = c * (\text{Phase}_{\text{rev}} - \text{Phase}_{\text{fwd}}) + d \quad (14)$$

The factors  $a$  and  $c$  and the additive components  $b$  and  $d$  have to be determined by measurements in the lab. These factors take into account the phase shift of the trace line between the coupler and the tuner as well as the asymmetry of the bidirectional coupler.

The tracking module also checks if the quality of measurement done is good enough and returns a quality indicator in addition to the reflection coefficient values. Although it is quite difficult to determine the accuracy of measurement receiver, following criteria have been decided after discussion with digital and analog designers to find out if the measured values are reliable enough for taking into use in the antenna tuning algorithm.

- If the amplitude of reflected power is measured to be higher than transmitted power, it is likely that the measurement is erroneous and hence should be ignored.
- If the delta between two consecutive measurements of reflected power amplitude is found to be greater than a defined threshold for the same frequency range and the same antenna conditions, the measurement is probably incorrect.

Reflection coefficient tracking module has interfaces with central control module and with power control module. It receives the request for triggering the reflection coefficient measurement from central control module and it forwards it to the power control module. As a result, it receives the amplitude and phase values of forward and reflected power from the power control module and it sends the resulting complex reflection coefficient values to the central control module.

### 3.1.1 Coexistence with other control algorithms

In order to fulfill the stringent output power requirements of WCDMA/LTE, a power control algorithm is executed on every slot or symbol boundary in the radio subsystem. This algorithm uses the measurement receiver to measure the transmitted power between one to three times on every execution. These measurements need to be done in a very short time period determined by the length of slot/symbol. In contrast, the antenna tuning functionality is not that time critical. It is anticipated that the change in position of antenna which makes it necessary to tune the impedance can occur in a time range of 0.5 seconds up to a few seconds. The time between the start of each execution of power control algorithm, on the other hand, is between 67 and 667 micro-seconds. So to simplify the control scheme and to avoid collisions in the usage of measurement receiver, the power control algorithm is the only one that is allowed to control the measurement receiver and request measurements from it. The flowchart given in Figure 21 shows the additional implementation in power control algorithm before the end of a slot to address this requirement. When the reflection coefficient tracking algorithm requests measurement data from the power control algorithm, the later checks, if it has sufficient time to trigger the measurements from the hardware before the end of the slot. If yes, then it immediately schedules the request to measure the amplitude and phase of reflected power and phase of transmitted power in addition to the regular request to measure the amplitude of transmitted power. If not, it keeps the request active and checks at the end of every power control execution whether time is left to do the additional measurements. When the data is available, it is returned to the reflection coefficient tracking module.

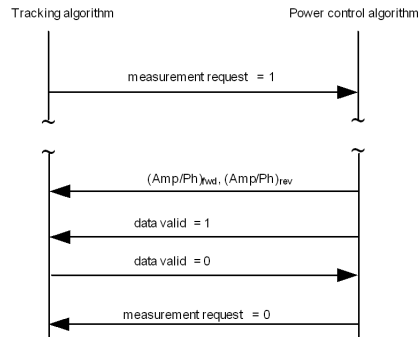

Figure 20: Interaction between tracking and power control algorithms

The interworking of both algorithms in case of a measurement request by the tracking algorithm is depicted in Figure 20. The tracking algorithm requests a measurement by setting  $\langle \text{measurement request} \rangle$  to 1. When available, the power control algorithm provides the data  $(\text{Amp/Ph})_{\text{fwd}}$  and  $(\text{Amp/Ph})_{\text{rev}}$  to the tracking algorithm and confirms the validity by setting  $\langle \text{data valid} \rangle$  to 1. The tracking algorithm confirms the reception by setting  $\langle \text{data valid} \rangle$  back to 0. The power control algorithm now finishes the measurement request by setting  $\langle \text{measurement request} \rangle$  to 0.

Check if time is too short  
to do measurement  
before next execution

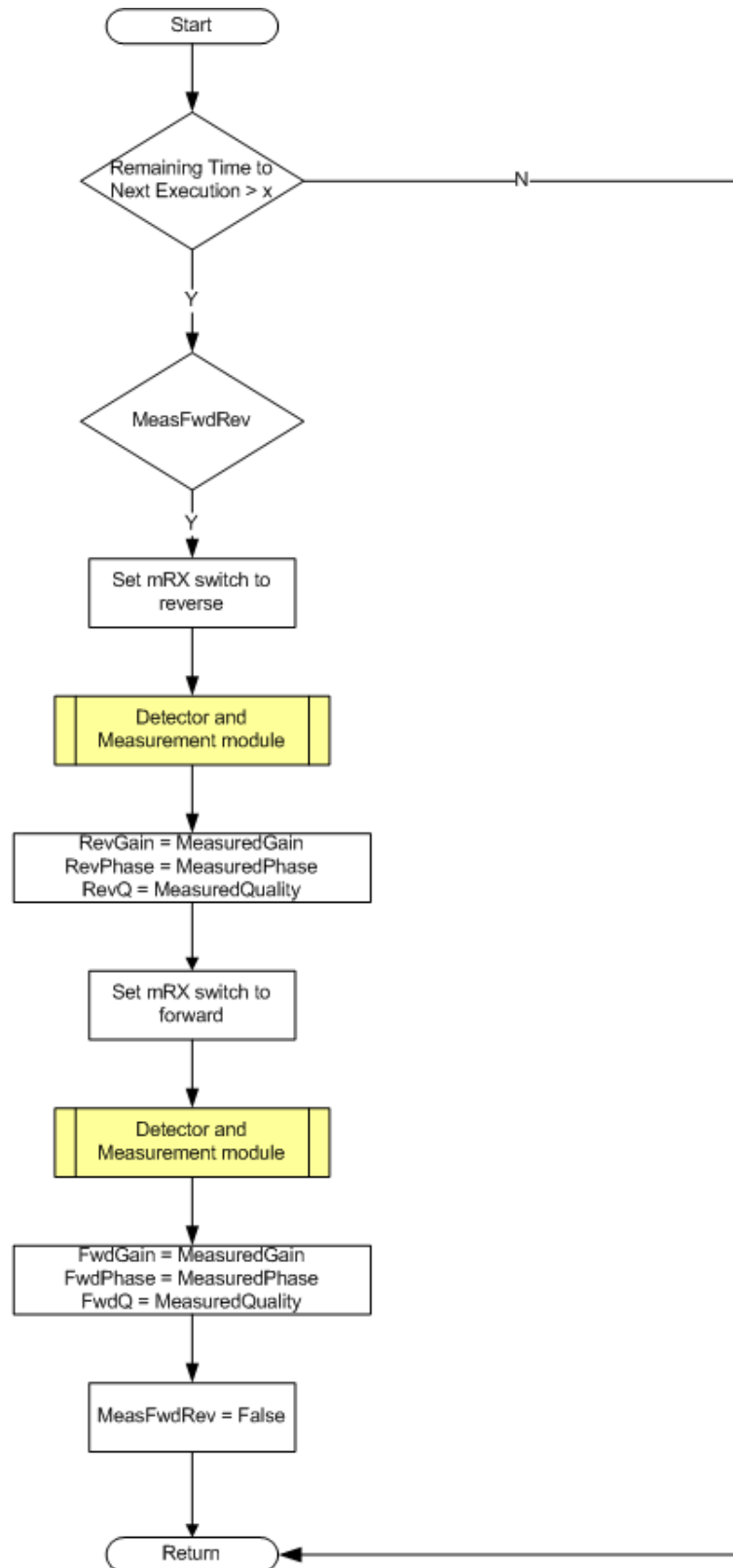

Figure 21: Flowchart for implementation in power control algorithm

## 3.2 Impedance calculation

Impedance calculation module is responsible for calculating the new impedance tuner settings in order to reach the best possible impedance match between the antenna and the radio module based on the result obtained from the reflection coefficient tracking algorithm. This module is also referred to as the antenna tuner control algorithm and is the most complex and critical part of the whole implementation. There can be several approaches to design this algorithm to achieve the following desirable features:

- Response time: The algorithm should converge to the best possible configuration for the impedance match in as few iterations as possible to ensure a fast response time for change in antenna condition.
- Accuracy: The tuned configuration determined by the algorithm should provide an impedance match as close to 50 ohms as possible.
- Flexibility: It is difficult to design a generic algorithm that is totally independent of the topology and technology used in the antenna tuner hardware. However the approach should be to have minimal dependence on the design of a particular tuner so that most of the algorithm can be used across multiple impedance tuner technologies.
- Processing power: The microprocessor in the radio transceiver that executes the tuner algorithm has limited memory and processing power. It does not support floating point numbers and complex arithmetic operations like division, square root etc. Hence the algorithm should use minimal computing resources.

All of the above desired characteristics cannot be achieved at the same time. One algorithm can converge to a perfect match very quickly but will be severely dependent on the knowledge of antenna tuner topology and hence will not work for any other tuner while another algorithm that focuses on accuracy and flexibility will take several iterations to converge. This section presents some algorithms that were written and analyzed during the course of this project.

### 3.2.1 Equation based algorithm

The approach used in this algorithm is based on the impedance matching theory described earlier. Maximum power can be delivered from the radio module to the antenna if the impedance of radio module ( $Z_S$ ) is a complex conjugate of the impedance of the antenna ( $Z_{ant}$ ). The impedance of the tuner ( $Z_{tuner}$ ) can be altered to achieve this match. This concept is depicted in Figure 22.

A similar analytical algorithm, based on the equations of a Pi-Network impedance tuner, is proposed in [18]. The extensive calculation procedures used by the proposed method, make it difficult to implement it in a micro-controller with a limited computation power. The Equation Based Algorithm proposed in this thesis work,

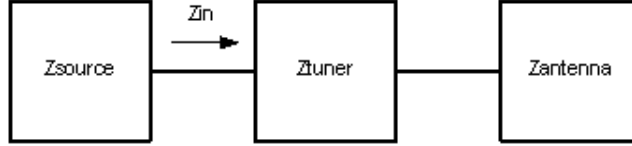

Figure 22: Impedance matching network

attempts to strike a balance between the computational complexity and the tuning time.

To start with, the first objective of this algorithm is to calculate the current antenna impedance in case of a mismatch. Hence once the measured reflection coefficient is available from the reflection coefficient tracking block, the first step is to calculate the input impedance ( $Z_{in}$ ) with the help of the following equation.

$$Z_{in} = Z_S \frac{1 + \Gamma}{1 - \Gamma} \quad (15)$$

The next step is to calculate the impedance of tuning element ( $Z_{tuner}$ ). The tuning circuit of STM-Paratek tuner (shown in Figure 16), used in this project, is that of a Pi-network. Hence the circuit shown in Figure 12 can be used here such that  $Y_A$ ,  $Z_B$  and  $Y_C$  are each composed of an inductor and a capacitor. The following equations depict the resulting impedance and admittances:

$$Y_A = \omega C_A - \frac{1}{\omega L_A} \quad (16)$$

$$Z_B = \omega L_B - \frac{1}{\omega C_B} \quad (17)$$

$$Y_C = \omega C_C - \frac{1}{\omega L_C} \quad (18)$$

Since the current configuration and topology of the antenna tuner is known,  $Y_A$ ,  $Z_B$  and  $Y_C$  can be easily calculated.

The third step is to calculate the antenna impedance. For this the equations derived in section 2.1.2 are used. The following equations reiterate this calculation.

$$Y_1 = \frac{1}{Z_{in}} - jY_C \quad (19)$$

$$Z_2 = \frac{1}{Y_1} - jZ_B \quad (20)$$

$$Y_{ant} = \frac{1}{Z_2} - jY_A \quad (21)$$

Once the antenna impedance is known, the next step is to calculate the values of matching components in order to achieve the target antenna impedance (50 ohms in most cases). As mentioned before, this is not a very straight-forward task in Pi-network and one way to simplify it is to split the Pi-network into two L matching

networks and match the source and antenna impedances to a common intermediate resistance ( $R_i$ ). Figure 23 shows such a split network.

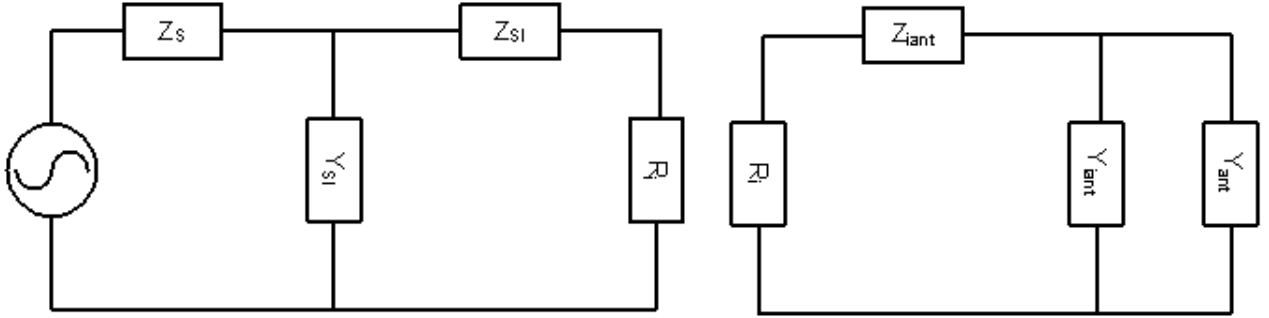

Figure 23: Split of Pi-network into two L matching networks

The split is done on  $Z_B$  such that the following equation holds.

$$Z_B = Z_{Si} + Z_{iant} \quad (22)$$

The choice of  $R_i$  can be determined by trial and error in the algorithm. Alternatively it can also be calculated with some characterization in the lab and then stored in the permanent memory for each sub-band and RAT. The algorithm then progresses as follows:

1. Assume a resistance for  $R_i$  that is smaller than the  $R_{ant}$  and the target (50 ohms).
2. Find impedance values for shunt and series components of both L-sections and combine their series components to calculate  $Z_B$ .
3. Since inductance is fixed, calculate the capacitance value of each of the three components.
4. Check if calculated values can be achieved by antenna tuner. Since the controlling factor in antenna tuner is voltage, it is not necessary that all capacitance values can be achieved.
5. If yes, apply the settings and measure the improvement in S11 if any.
6. If not, go to step 1.

This equation based approach provides a near accurate configuration for the impedance tuner for a perfect match in the least possible number of iterations. However it does not take into account the parasitic effect of the components. Therefore the obtained result will not be that accurate. Also, it is necessary to know the circuit and layout of the impedance tuner prior to designing this kind of algorithm. Hence it is the least flexible of all the algorithms analyzed in this project. Another disadvantage is that the equation based method involves several arithmetic calculations that are neither easy nor efficient to implement in the radio transceiver microprocessor.

### 3.2.2 Gradient Search algorithm

A Gradient Search algorithm is basically a general purpose random search algorithm that is based on the principle that the next possible candidate point is based on the current point and the previous points [19]. A candidate point  $V_{k+1}$  is generated by taking a step  $S_k$  in a vector direction  $D_k$  from the current point  $X_k$ .

$$V_{k+1} = X_k + S_k D_k \quad (23)$$

The vector direction is determined by the information about the gradient which in turn is based upon information of the previous behavior of the vector or in some cases, on the uniform distribution pattern of the available data. The step size is generally determined by the distance from the target condition but can shrink or expand depending on several conditions. As long as the step direction is close to the gradient, this kind of algorithm is guaranteed to converge though there is a risk of running into local minima.

The above approach can be applied to the problem at hand i.e. closed loop antenna tuning [20]. The current point  $X_k$  is the set of capacitor control voltages ( $V_a, V_b, V_c$ ) that determine the antenna tuner settings at any instant of time. The candidate point  $V_{k+1}$  refers to the antenna tuner settings that produce the desired impedance that would match the antenna impedance to that of radio module. Step size  $S_k$  is the distance of the current antenna impedance from the desired one and  $D_k$  is the gradient that needs to be calculated. Two possible methodologies of calculating the gradient are explained here.

- Pre-determined Gradient control: The basic idea in this algorithm is to characterize the antenna tuner for different antenna conditions and operational frequencies and store the results in the permanent memory. In practice, this means that for each capacitor in the antenna tuner configuration, we record the change in effective antenna impedance with the change in capacitor voltage while keeping the other two capacitor voltages constant. The data is then plotted as two separate graphs in the form of real input antenna impedance vs capacitance voltage and imaginary input antenna impedance vs capacitance voltage. Based on the data provided by the antenna tuner manufacturer, we know that the shape of the curve showing the variation of antenna impedance with capacitor voltage is almost the same irrespective of antenna condition even if the absolute values are different. Same is true for similar curves plotted for different values of capacitance voltages for other two capacitors. Hence we can approximate the curve into a polynomial by means of polynomial curve fitting and determine the coefficients that best fit into the measurement data in the least-squares sense. Based on the provided data it seems that a third order polynomial is sufficient to match the curve shapes with sufficient accuracy. The values of coefficients  $x_1, x_2$  and  $x_3$  for real and imaginary antenna impedance for all the three capacitances, are stored in the permanent memory. The effective antenna impedance at any instant for a given input capacitor voltage  $V_A$  is given by the following equation:

$$G_{in} = x_3 * V_A^3 + x_2 * V_A^2 + x_1 * V_A + x_0 \quad (24)$$

Since we need the gradient of the curve for the antenna tuning algorithm, a derivative of the given polynomial is required as shown in the equation below.

$$G_{in} = 3 * x_3 * V_A^2 + 2 * x_2 * V_A + x_1 \quad (25)$$

Once the characterization of the antenna tuner is done, the following steps constitute the antenna tuning algorithm in case of an impedance mismatch:

1. Measure the amplitude and the phase of the reflection coefficient
2. Measure the delta between the measured values and the target values for a perfect match
3. If the delta is above a certain threshold, the gradient (real and imaginary components) needs to be calculated using equation for each of the three capacitor voltages.
4. Compare the calculated gradient with the delta for each capacitance and rate them.
5. Choose the capacitor voltage whose gradient best reduces the distance between the measured and the target values in both real and imaginary planes.
6. Calculate the new HVDAC settings as per the chosen capacitor and its gradient.
7. Go to step 1.

The advantage with this approach is that it is quite generic and can be applied to any antenna tuner irrespective of its configuration and without detailed knowledge of its schematic and layout details. Also its convergence to a tuned impedance is more or less guaranteed. However, the number of steps and hence the time taken to converge, and the accuracy of match, may vary. The main disadvantage of this methodology is that extensive measurements in the laboratory need to be carried out in order to characterize the antenna tuner before it is possible to take this algorithm into use. Accurate characterization of the tuner over all the RATs and the frequency channels is the key to success for this approach so support from automated tools is also required. This makes the setup more cumbersome and time consuming. Also, quite a lot of memory is needed to save the coefficient values for each capacitor and for each RAT and frequency channel.

- Auto-didactic Gradient control: One way to avoid the extensive characterization of antenna tuner is an iterative self-learning approach where the coefficients are not stored in advance, rather the gradient is calculated during the tuning process. In each iteration of the algorithm, a step is taken to increase

one of the capacitor voltages and its impact on the reflection coefficient and distance from the target value is recorded. A gradient is then calculated for the real and imaginary components of the impedance as shown below:

$$\text{slope}_{\text{real}} = \frac{\Delta G}{\Delta V_x} \quad (26)$$

$$\text{slope}_{\text{imag}} = \frac{\Delta B}{\Delta V_x} \quad (27)$$

Once the gradients are calculated for all the three capacitors, they are then compared and rated and finally the best one is chosen in the same way as shown in pre-determined gradient control algorithm. Thereafter, another set of measurement is started and a new set of gradients is calculated with respect to the HVDAC setting selected in the previous step. This process continues until a satisfactory impedance match is obtained.

This algorithm does not need much memory or computational power and its convergence probability is very high. There is also no dependence at all on the antenna tuner topology. The downside is that the settling time for finding an impedance match is longer.

### 3.2.3 Hill Climbing algorithm

In order to make the algorithm completely independent of the antenna tuner topology, as well as to reduce the dependence on the accuracy of the reflection coefficient returned by the measurement receiver, it can be useful to adopt an adaptive random search approach. By definition, the random search samples repeatedly in a feasible range, according to uniform sampling distribution such that each sample is independently and identically distributed. If pure random search or blind search is performed, the algorithm is guaranteed to find a global minima but the very long settling time renders this approach infeasible. Hence an adaptive methodology of local search [21] is required where the next candidate point is found in a strictly improving direction. It can be described as an iterative improvement algorithm that tries to improve the current state by making small changes in each iteration until no further improvement is possible. One such algorithm in the family of iterative local search algorithms is called Hill Climbing [22]. It attempts to minimize or maximize a cost function  $f(x)$  where  $x$  are discrete states.

$$X_{k+1} = \begin{cases} V_{k+1} & \text{if } f(V_{k+1}) < f(X_k) \\ X_k & \text{otherwise.} \end{cases}$$

In some ways, this algorithm is similar to the Gradient Search algorithm described before with the difference that it is not necessary to know the strength or direction of the gradient. Instead, iterative steps of fixed size are made and new ones are adopted if they show better performance. On the other hand, it is possible to sample the performance at all the possible steps from the original solution and

then select the best one. Such an approach is referred to as Steepest Ascent Hill Climbing. Hill climbing suffers from a problem that it can get stuck on a local maxima or minima (illustrated in Figure 24) depending on the starting point but in most cases [23] [24], it gives equally good or better results than more complex algorithms.

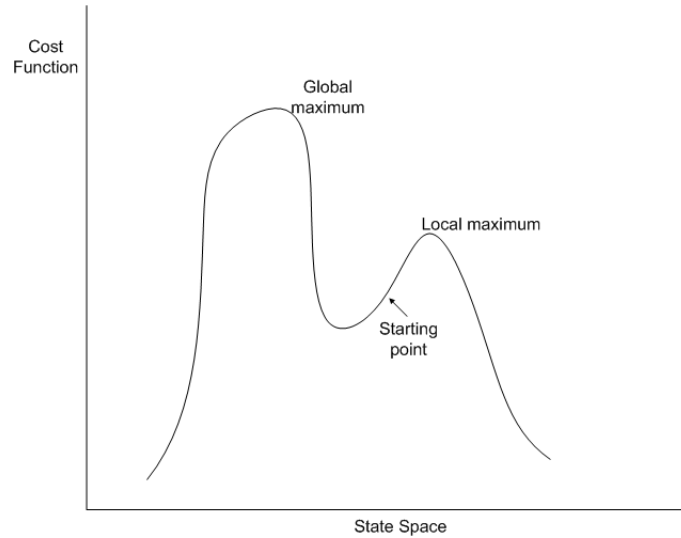

Figure 24: Hill Climbing

The Hill Climbing algorithm is best suited to situations where the heuristic gradually improves as the solution gets closer. The impedance tuning problem falls in this category as the reflection coefficient tends to improve as the antenna tuner configuration approaches the optimum. An antenna tuner system with three variable capacitors can be considered a three dimensional space for a search algorithm. The starting point is either arbitrarily chosen or on the basis of open loop settings. Search for a candidate point is made in six directions, incrementing or decrementing the voltage of each capacitor by a predefined delta while keeping the other two capacitor voltages constant. The resulting reflection coefficients from these six steps are then compared and the one showing best results in terms of minimum distance from the target impedance is chosen. This loop continues till the best possible position in the three dimensional space is reached, such that moving further in any of the six directions would give worse results.

There are some disadvantages in adopting this algorithm. One is that the settling time is quite long. The shorter the step size, the longer is the settling time but on the other hand, choosing a longer step size compromises the accuracy. Hence a compromise has to be made and a trial and error process is required to find an optimum step size i.e. the delta in capacitor voltage. Another problem with this algorithm is that in most cases the tuned antenna configuration would be a local minima since three variable elements make it an over-determined system. Nevertheless the flexibility and the ease of use offered by this algorithm makes it worth considering.

### 3.3 Common algorithm control

Common algorithm control module is the central antenna tuning control block of the RF sub-system. It is in charge of the antenna tuner state machine i.e. the state of antenna tuner in different operating modes and the state transitions. It has interfaces to the reflection coefficient tracking block, the impedance calculation block and to the algorithm database. The following sub-sections describe the tasks of the single states of the antenna tuner state machine as well as the state transitions.

#### 3.3.1 Operating modes

A central control block is commonly used in systems that perform repetitive tracking. A combination of Open and Closed Loop [25] is often used to design this control module such that the Open Loop works on prior knowledge while the Closed Loop uses feedback information to regulate the changes and uncertainties in the system. Since the Open-Plus-Closed-Loop Control combines the advantages of both feedback and non-feedback based approaches, it is widely used in theoretical [26] as well as practical applications [27] [28]. This design methodology also meets the requirements of antenna impedance tuning system and is therefore used in this thesis work.

When the radio sub-system is activated by the baseband from a standby state to perform transmission or reception (Tx On or Rx On), the antenna tuner system also gets activated and enters an initial state of Open Loop. At this stage the antenna condition and its impedance is unknown hence the antenna tuner HVDAC settings are decided on the basis of current frequency band and RAT. These antenna tuner settings for different frequency ranges have been determined in advance during characterization of the hardware in the lab and stored in the permanent memory of the device. These stored settings are referred to as algorithm database. Besides the initial state, the antenna tuner system also remains in the open loop mode if the transmit power level is very low. This is because the dynamic range of measurement receiver is such that it is not possible to detect signal at a power level below a certain threshold. When the transmit power is low, the reflected power is even lower which makes it impossible for the measurement receiver to report sensible data needed for the calculation of the reflection coefficient.

As soon as the output power level is above the threshold, the system is switched to Closed Loop. A request is sent to the tracking algorithm to trigger the measurement of the forward and the reflected signals. The reflection coefficient value returned by the tracking module is then sent to the impedance calculation module to determine the new values of the HVDACs to ensure a better match. The Closed Loop remains operational as long as the resulting VSWR does not reach an acceptable value. The only exception to this is when the measurement receiver accuracy qualifier returned by the tracking module is found to be bad. In the absence of reliable feedback information, the system switches to Broken Loop [29]. Broken Loop means that the last valid impedance tuner settings from Closed Loop mode remain unchanged. If the transmitter is turned off or if the transmitted power level drops below the threshold, the system switches back to Open loop from Closed Loop or Broken Loop. Also, if the antenna condition changes, Open Loop comes into effect immediately.

### 3.3.2 Antenna tuner state machine

- Initial State Transition to Open Loop: When triggered into the initial Open Loop state, the antenna tuner algorithm also gets information about the current RAT, frequency of uplink/downlink and antenna condition. Based on this information, the algorithm looks for valid HVDAC settings from the algorithm database. If there are no valid settings available for the current frequency, the algorithm tries to find the data for corresponding sub-band in the same RAT. Once the settings are available, they are provided to the MIPI RFFE driver and the execution is triggered.
- Open Loop: When in Open Loop state, the algorithm performs the following sequence of tasks also shown in Figure 25:
  1. It checks whether the antenna condition changed since the last time when HVDAC settings were applied. If this is not the case, the applied HVDAC settings are up-to-date and need not to be applied again. Else, it gets the open loop HVDAC settings for the requested sub-band, RAT and antenna condition from the database.
  2. It might be possible that the complete HVDAC settings cannot be applied in a single execution so that no disturbance is caused to the radio module functionality. In this case the common algorithm control block partitions the HVDAC settings into  $n$  steps. It stores the number of remaining steps together with a timestamp indicating when it was used last in the algorithm database and provides the HVDAC settings of one step to the MIPI RFFE driver.
  3. It checks whether all steps to apply the HVDAC settings are done. If not, it provides the HVDAC settings of next step to the MIPI RFFE driver. If the last step is applied, it also stores the now valid HVDAC settings in the algorithm database.
  4. If the transmit power level exceeds the threshold, the state is changed to Closed Loop else the algorithm remains in Open Loop state.

If the antenna condition changes while the above sequence of steps are being executed, the Open Loop sequence is triggered to start from the beginning.

- Closed Loop: When in the Closed Loop state, the antenna tuner state machine triggers measurements of the reflection coefficient, calculates the  $S_{11}$  and the impedances and applies the new HVDAC settings. Closed Loop state can be segmented into three sub-states each of which have a set of input and output parameters and are triggered by specific events. Figure 26 shows the Closed Loop state machine.

The tasks of these sub-states are as follows:

- Set-up state: This is the beginning state of the Closed Loop state machine. It has the following tasks (Figure 27):

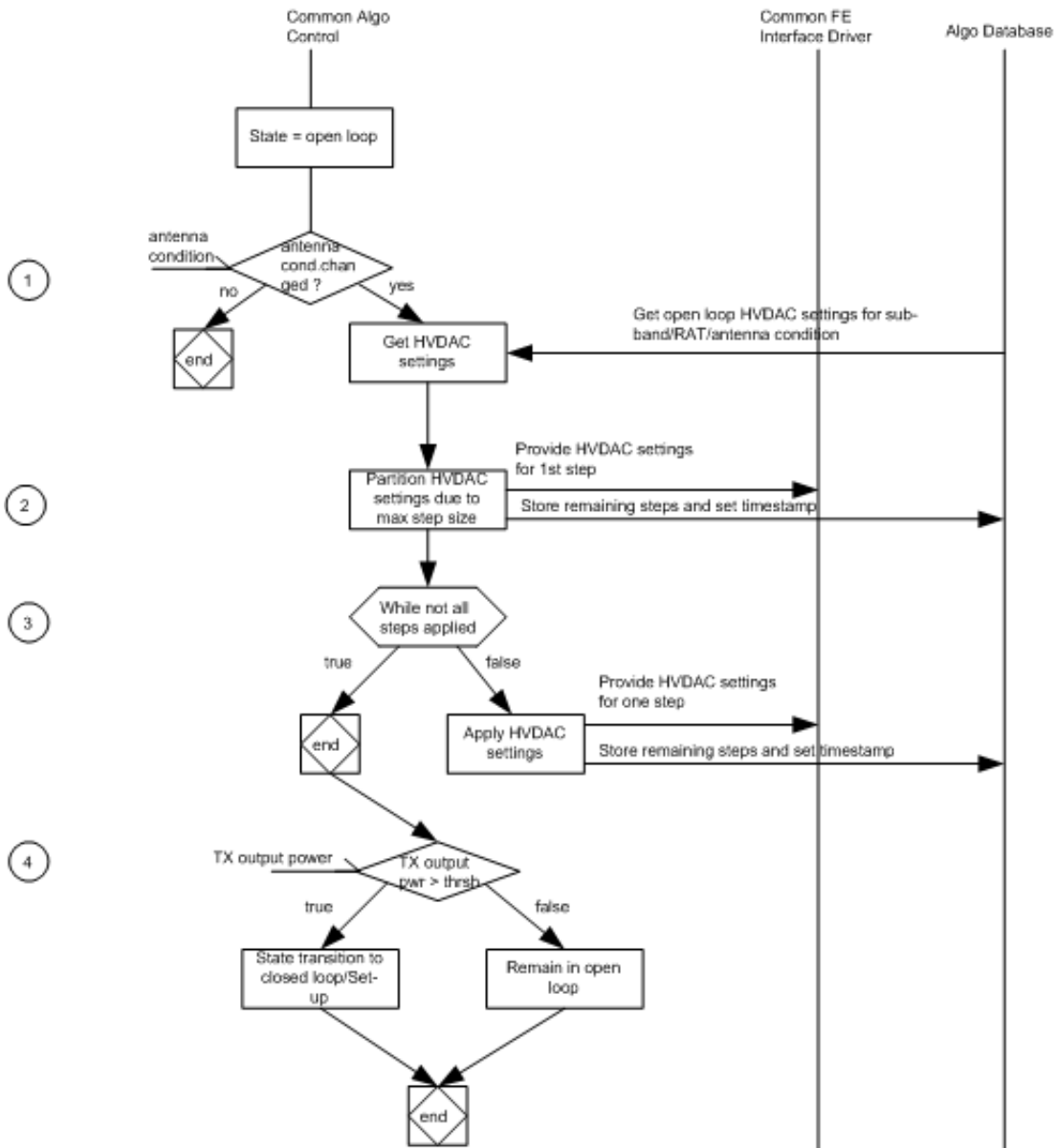

Figure 25: Open Loop mode

1. It checks if the transmit power level is above a given threshold. If not, it switches back to Open Loop.
2. It initializes the measurement receiver and requests the measurement of magnitude and phase of forward and reflected power. The measurement receiver is actually controlled by the power control module and has a higher priority over antenna tuning task. Hence the antenna tuner algorithm in effect sends a measurement request to the power control module and waits till the results are available.
3. It moves to Calculate state once the measurement results are reported by the power control module.

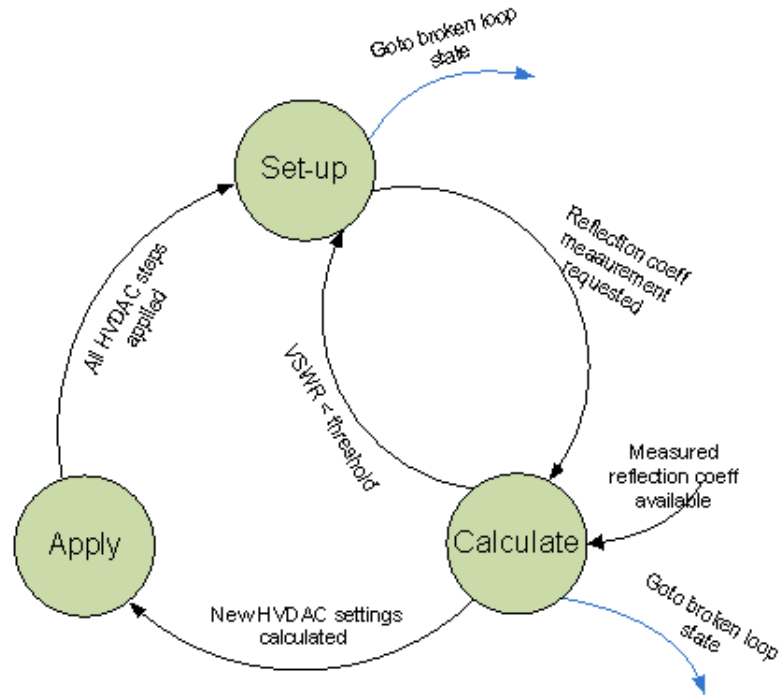

Figure 26: Closed Loop state machine

- Calculate state: This is the most complex state of antenna tuning algorithm where all the impedance calculation logic resides. The tasks performed in this state are as follows (Figure 28):
  1. It checks if the quality of measurement results is good enough. If not, it switches to Broken Loop.
  2. It calculates the value of reflection coefficient and VSWR corresponding to measured values of forward and reflected power with the help of the Impedance Calculation Block.
  3. If the calculated value of VSWR is found close to the ideal value it means that the impedance match is already good making any changes to the tuner will worsen the antenna tuning. In this case, the Closed Loop state machine moves back to Set-up state without moving to Apply state.
  4. If the distance between the measured reflection coefficient and ideal one is found to be large enough, the antenna tuner algorithm retrieves the current open loop settings from the database and triggers the impedance calculation block for a calculation of the new HVDAC settings based on the current HVDAC settings and the measured reflection coefficient.
  5. If the new settings need to be applied in smaller steps, those steps are calculated.
  6. Transition is made to Apply state with the new HVDAC settings as

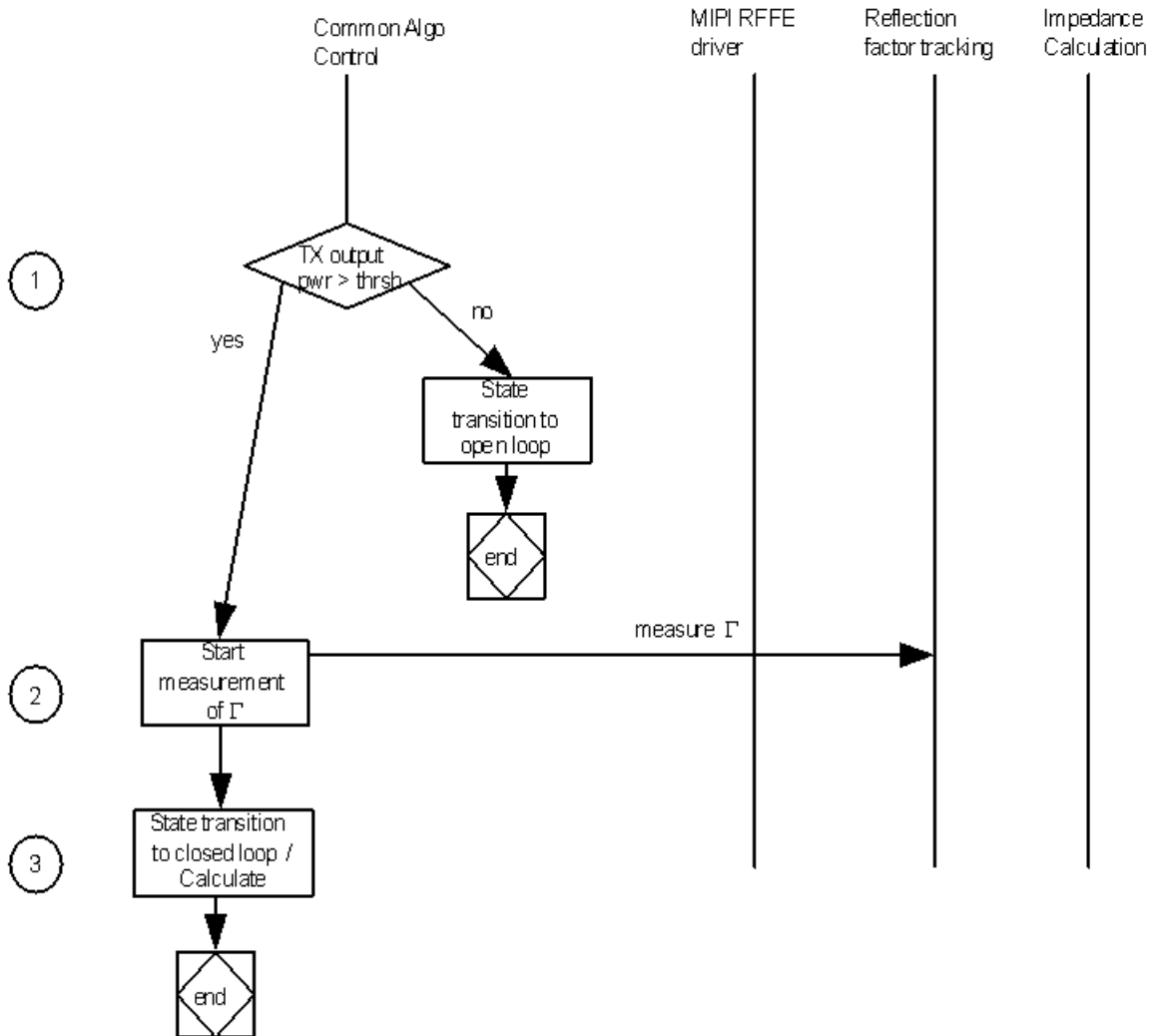

Figure 27: Closed Loop, Set-up state

input.

- Apply state: In this state, the antenna tuner algorithm interacts with the MIPI RFFE driver to apply the new HVDAC settings (Figure 29). It remains in this state till all the settings are applied. Once done, it stores the current applied HVDAC settings into the database and moves back to Set-up state. Depending on the impedance calculation algorithm used, there might be several iterations between the Calculate and Apply state before the correct antenna tuner settings are found.
- Broken Loop: Broken Loop comes into effect if the measurement receiver is not able to measure a valid reflection coefficient. As soon as the quality of measurement is restored, the antenna tuner algorithm switches back to Closed Loop mode. On the other hand, if the measurement continues to be invalid for a defined period of time, the state machine moves to Open Loop mode. While

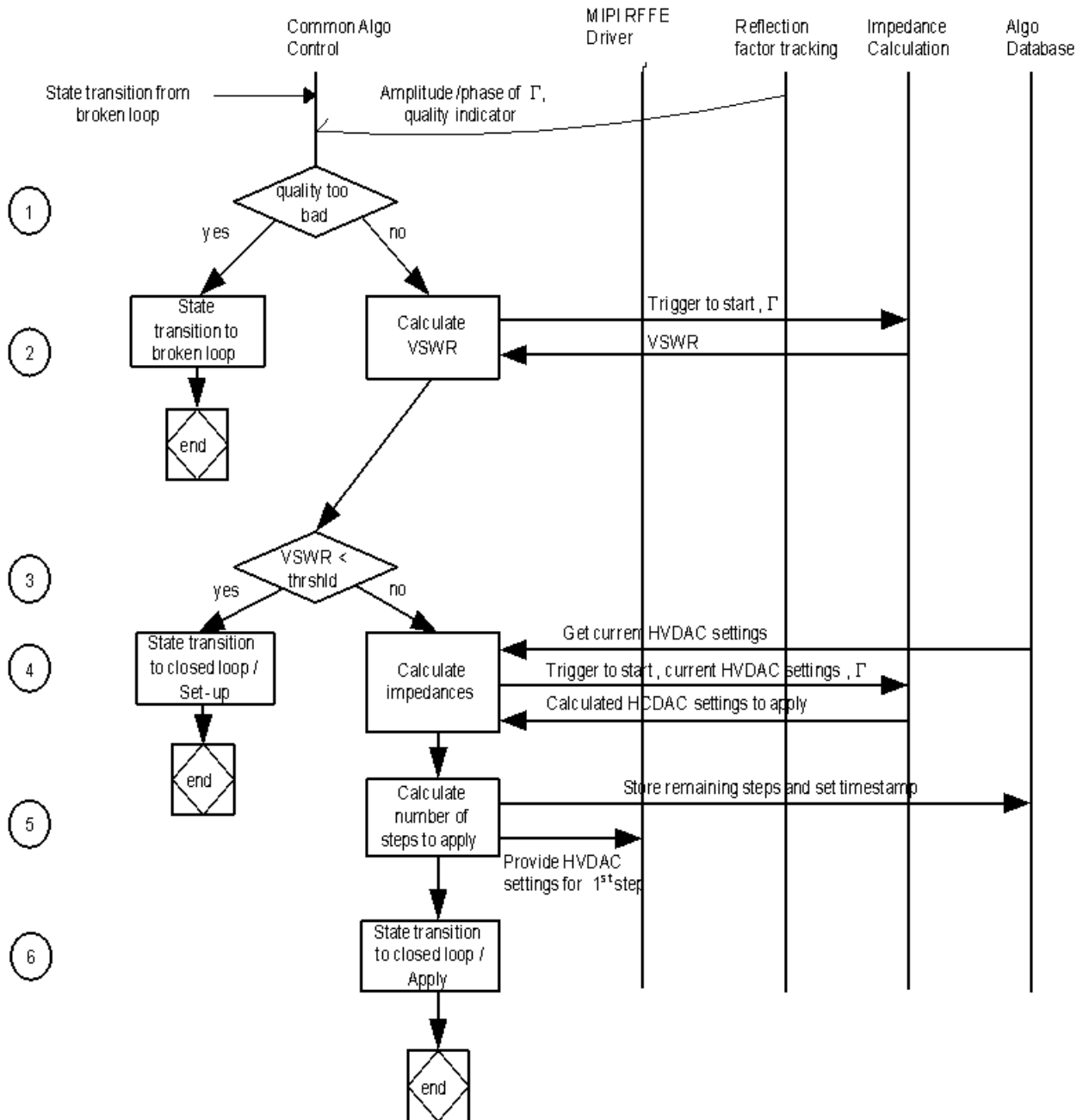

Figure 28: Closed Loop, Calculate state

in the Broken Loop state, the antenna tuner algorithm performs the following tasks (Figure 30):

1. It checks if the time elapsed since the beginning of this state has exceeded the defined limit. If yes, it means that the quality of measurement continues to be bad so the algorithm switches to Open Loop.
2. It checks if the transmit power level is above the predefined threshold set

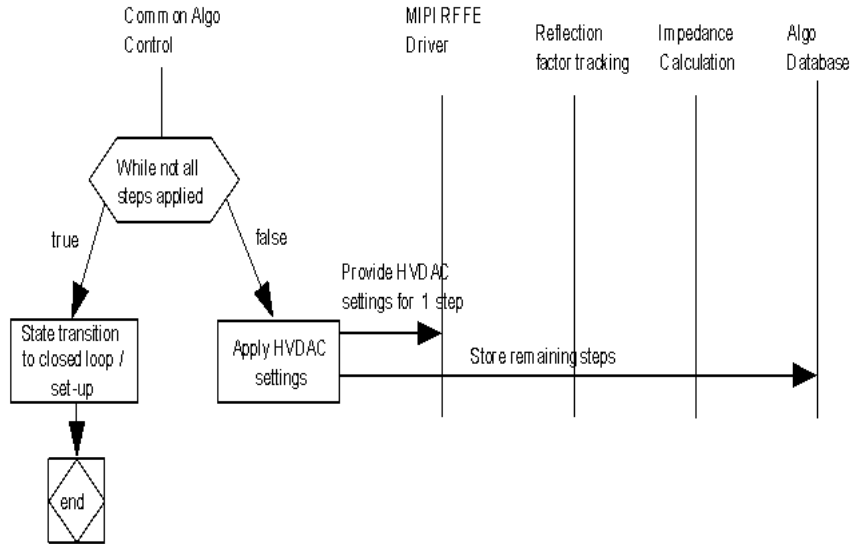

Figure 29: Closed Loop, Apply state

for Closed Loop operation. If not, it switches to Open Loop.

3. It triggers the measurement of forward and reflected powers from the measurement receiver through the power control module. Since the measurement request scheduling depends on the power control module, the antenna tuner algorithm waits for the result.
4. Once the measurement results are available, it checks the validity of the measured reflection coefficient. If the quality is bad, it stays in Broken Loop mode i.e. it makes no change to the last applied HVDAC settings to the antenna tuner.
5. If accurate measurement results are obtained from the measurement receiver, it switches to Closed Loop mode.

### 3.4 Timing considerations

The RF transceiver is totally controlled by the baseband through a set of control commands and response messages. These commands configure the transceiver and trigger the transition between its different states. The transceiver is not aware of the high level communication flow with the base station. It knows about its own state and configuration but not when a transition will occur. Hence it is extremely critical for all the sub-modules included in or interacting with the radio module to be aware of the timing constraint imposed by the transceiver states so that the transceiver is not in a busy or invalid state when a trigger arrives from the baseband to switch to another state. This applies to antenna tuner module as well. It is assumed though that no drastic change happens in the antenna condition and hence in antenna impedance within a time period of 0.5 seconds. This chapter describes the timing

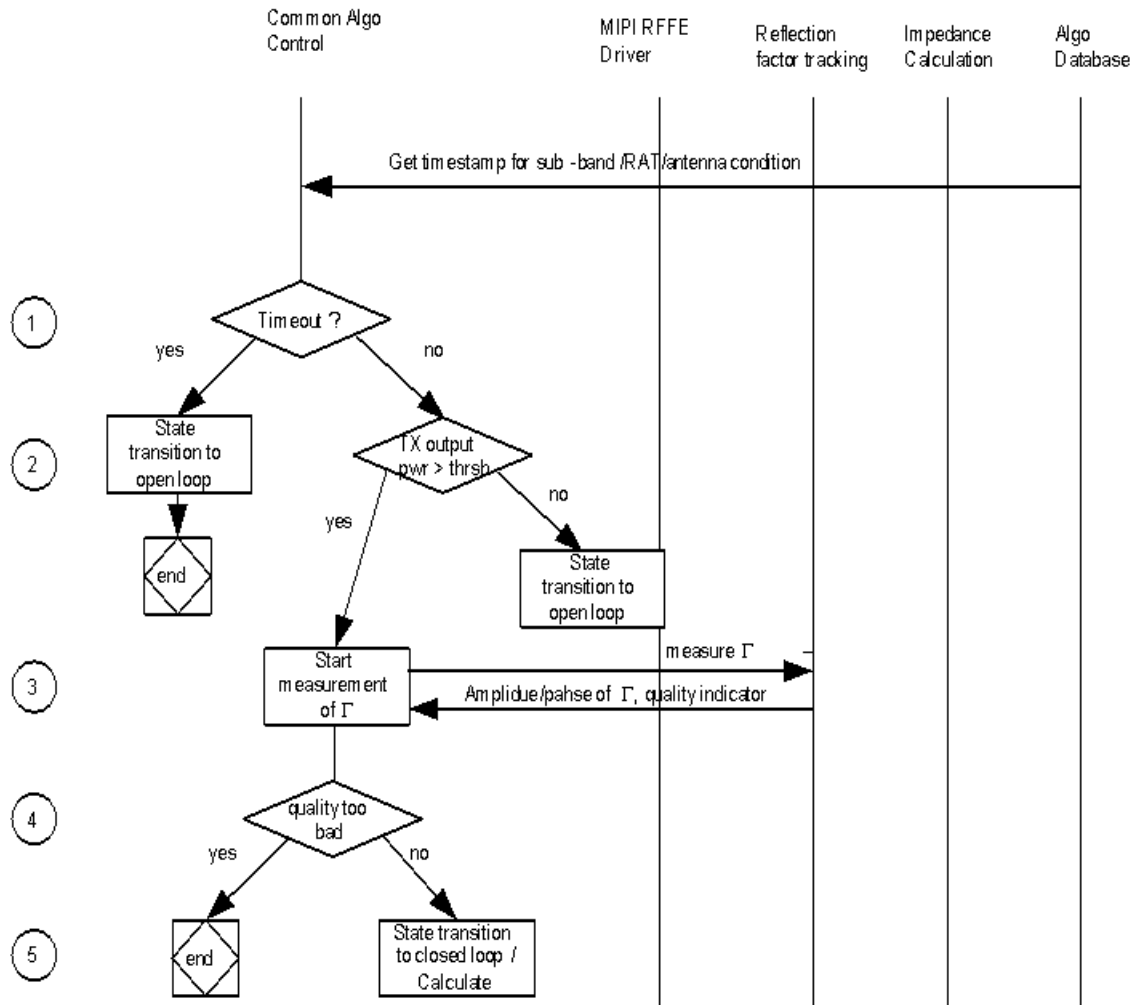

Figure 30: Broken Loop mode

constraints of different radio access technologies (RAT) that have an important effect on the antenna tuning algorithm. The timing requirements of antenna tuner hardware are also presented.

### 3.4.1 RAT specific timings

The baseband control interface of the radio module used in this project consists of control commands and Time Accurate Strokes (TAS) [30]. The control commands contain all information necessary to configure the RF subsystem and the TAS messages enable precise timing. The execution of the command starts when the corresponding TAS arrives. The minimum time between the TAS and the start of reception or transmission is determined by the  $150 \mu s$  synthesizer settling time. Within this period the tuner software has to find the appropriate tuner setting and the tuner must be in steady state. RAT specific aspects of this timing constraint

are described below.

**GSM:** GSM is a half duplex FDD (Frequency Division Duplex) system where transmitter and receiver are never turned on at the same time. The basic unit of transmission is called a burst that lasts for 0.577 ms. Eight such bursts form one TDMA frame with a length of 4.615 ms. Within this time the antenna impedance does not change significantly and there is no need to update the tuner settings during the burst. The approach is to configure the impedance tuner before the burst together with the other front end components.

The optimum tuner settings for best impedance match and minimum reflected power, change with frequency. Since the transmitter and receiver are operating at different frequencies, it is necessary to have separate open loop impedance tuner settings for the transmitter and the receiver. However, it will be an overkill in terms of memory to have one setting for each ARFCN (Absolute Radio-Frequency Channel Number). On the other hand, accuracy will be compromised if only one setting is stored per band. The middle path solution chosen in this project is to split each band into three sub-bands and to store one setting for each sub-band.

**WCDMA:** WCDMA is a full duplex communication technology with simultaneous transmission and reception. With the exception of the DTX/DRX (discontinuous transmission/reception) [31] and the compressed mode gaps, the receiver and transmitter are continuously enabled. Each radio frame is 10 ms long and consists of 5 sub-frames. Each sub-frame has 3 slots and the duration of each slot is approximately  $667 \mu s$ . Since the antenna condition and hence its impedance can change significantly within 0.5s, it is not efficient to wait for a gap in the transmission. So the antenna tuner setting has to be updated while the transmission and reception is ongoing. This update of the tunable capacitance values can cause fluctuations of power amplitude and phase disturbing the channel estimator and other blocks in the receiver baseband chain. Such an impact can be mitigated if care is taken that the tuner settings are changed in small steps. For example, if only a single DAC is changed by one LSB per slot, the fluctuation can be kept minimal. In order to make a full sweep on all the three capacitors each controlled by an 8 bit DAC, this would take  $3 * 256 * 667 \mu s = 512 ms$ . Hence, even in the worst case scenario where the antenna tuner settings are completely wrong, the small step is sufficient to change the impedance in a non time critical way. The small steps also ensure that the change in impedance tuner setting has a minimum impact on the existing transmitter power control algorithm. As a result the setting can be changed anytime in the TX and RX slot.

Another aspect of implementing antenna tuning in a WCDMA system is the difference in optimum tuner settings for transmission and reception. Since transmitter and receiver are operating on different frequencies, it is obvious that they will have different tuned settings but due to the fact that both are active at the same time, a compromise has to be made between the best settings for transmission and for reception. Hence a common target tuner setting is chosen for Tx and Rx for each sub-band.

**LTE FDD:** LTE FDD is also a full duplex system like WCDMA, with transmission and reception happening at the same time at different frequencies. The radio

frame duration is 10ms and consists of 20 slots with a slot duration of 0.5ms. Two adjacent slots form one sub-frame of length 1ms. The same concepts of doing tuner setting updates in small steps and finding a compromise between optimum settings for transmission and reception, apply here as well.

**LTE TDD:** LTE TDD is based on time division duplexing where transmitter and receiver operate on the same frequency but at different times. So Tx and Rx is never operational at the same time. The frame and sub-frame structure of LTE TDD is not too different from LTE FDD except for certain special sub-frames like DwPTS (Downlink Pilot Time Slot), GP (Guard Period) and UpPTS (Uplink Pilot Time Slot) that are meant for supporting the switching between transmission and reception and for carrying synchronization and control information. The switching between transmission and reception is defined by the Guard Period and can take approximately 20  $\mu$ s to 700  $\mu$ s depending on the configuration and timing advance. It is best to apply the tuner settings in this time frame since both transmitter and receiver are inactive and multiple small steps are necessary.

Since the transmitter and receiver are operating at the same frequency, the obvious approach is to use the same impedance tuner settings in open loop mode for transmission and reception. But the tuner settings that are optimum for Tx are not necessarily the best for Rx. So an approach similar to GSM is used for storing the open loop and closed loop target settings.

### 3.4.2 MIPI RFFE timings

The MIPI RF front end interface works with a nominal clock speed of 26MHz. A normal register write consists of 25 Bits and takes 0.96 $\mu$ s. A normal register read consists of 26 Bits and takes 1 $\mu$ s. As mentioned before, the antenna tuner consists of three tunable capacitors where each capacitor has a separate bias voltage controlled by HVDACs. The bias voltage level is controlled by an 8-bit DAC. By using trigger mode the values stored in all the three DACs can be activated at once. One tuning step is composed of three register writes for voltage programming and one register write for the trigger event. The total programming time is  $4 * 0.96\mu\text{s} = 3.84\mu\text{s}$ . In addition the STM Paratek tuner has a settling time of 300  $\mu$ s when switched on for the first time and 50  $\mu$ s for each HVDAC setting. The HVDAC settling time is quite short compared to other timings in RF transceiver for eg. Synthesizer settling time and hence will have a negligible effect on the RAT timings. However it is necessary to use the Trigger mode described before so that all the voltage settings are applied all at once thus minimizing the settling time. The initial settling time when the tuner is switched on for the first time is rather long and therefore we decided to switch on the tuner at the time of RF transceiver initialization and then to keep it powered on all the time. The current consumption of the tuner is very little so it is not a problem to keep it powered on.

### 3.5 Performance degradation considerations

Using an antenna tuner in the transceiver path reduces mismatch which improves the TRP in the context of transmission and TIS for reception. Reducing the mismatch loss also improves the current consumption as the power amplifier's output power is reduced. However, the antenna tuner also introduces some insertion loss. In addition, the control updates during closed loop control introduce dynamic performance limitations due to changing transfer function of the antenna impedance tuner. How much the performance is degraded depends on the magnitude and phase response change of the transfer function vs. time. Depending on the RAT and whether the transmitter or receiver is considered, this response has different impact on the system performance. This section focuses on this performance degradation and introduces parameters that should be measured in the course of developing the antenna tuning system in order to ensure system performance.

#### 3.5.1 Error Vector Magnitude

Error Vector Magnitude (EVM) is a measure of the distance between received symbols and the ideal symbols in the I-Q plane. It is used extensively to quantify the performance of a digital radio system since the deviation of the constellation points from their correct locations is caused by the imperfections in the implementation. A large value of EVM leads to poor detection accuracy which can be regarded as degraded transceiver performance. Mathematically it is defined as the ratio of the power of the error vector to the average power of the reference constellation. It is mostly expressed in percentage as follows:

$$\text{EVM}(\%) = \sqrt{\frac{P_{\text{error}}}{P_{\text{reference}}}} * 100\% \quad (28)$$

When the capacitor values are modified in the course of the closed loop tuning process, it also changes the transfer function of the impedance tuner. Hence a signal passing through the tuner undergoes a shift of phase and amplitude which has a direct impact on its EVM. Hence EVM can be used as a reference when analyzing the impact of changing the antenna impedance tuner settings. Exceeding the target EVM values cause an unacceptable degradation in BER (Bit Error Rate) and throughput. 3GPP specifications have laid down strict requirements on the amount of EVM that can be tolerated in the transmitter and in the receiver for different RATs. The amount varies between 4% (for WCDMA) and 12.5% (for LTE).

#### 3.5.2 Linearity

Non-linear behavior of a radio system generates intermodulation products that in turn lead to out-of-band emissions or spectral re-growth resulting in increased transmission bandwidth and interference in adjacent channels. As for any other RF device, linearity for impedance tuner can be quantified in terms of ACLR (Adjacent

Channel Leakage Ratio). ACLR is defined as the ratio of the transmitted power to the power measured after a receiver filter in the adjacent RF channel. The ACLR limits imposed by 3GPP specifications are 33 dBc for an adjacent channel frequency of  $\pm 5$  MHz and 43 dBc for  $\pm 10$  MHz. All the front end components like the power amplifier, the main Front End Module (FEM), switches etc., exhibit non-linear behavior to a certain extent [32]. Hence most of the linearity budget available in a radio system is used up by them. That is why it is extremely important that the linearity of impedance tuner should not significantly worsen platform performance and therefore must be equal or greater than linearity of main FEM switch.

### 3.5.3 Insertion loss

Insertion loss for an antenna impedance tuner can be defined as the loss in the output power when the tuner is inserted between the RF module and the antenna in ideal conditions i.e. a 50 ohm load. Hence the insertion loss can be quantified in terms of output power. Since the ideal 50 ohm load condition rarely exists, the improvement in mismatch loss provided by the antenna tuner mostly offsets the insertion loss. For example, a VSWR of 7:1 for an antenna means a mismatch loss of 3.6dB. If the impedance tuner has an insertion loss of 2dB but is able to match the antenna impedance to that of the transceiver such that the VSWR is 2:1, then there is still a substantial benefit. Insertion loss depends totally on the tuner topology. The STM Paratek tuner used in this project has an insertion loss of approximately 0.5 dB in high band and 1 dB in low band.

### 3.5.4 Reflection coefficient accuracy

The success of closed loop tuning depends to a large extent on the accuracy of measured values of transmitted and reflected power by the measurement receiver. The operational power range of closed loop antenna tuning depends on the sensitivity of measurement receiver which in turn depends on its noise figure and used bandwidth. For accurate measurement of power and phase, the measurement receiver needs a minimum signal to noise ratio of 20dB. In addition to the thermal noise, the performance of the measurement receiver is limited by the transmitted signal direct leaking to its input pin. The leaking signal is coherent to the measured signal and depending on the relative phase angle, it either increases or decreases the measured signal amplitude. This sets high isolation requirements from the antenna, the power amplifier output and the modulator output to the inputs of the measurement receiver. Therefore the overall measurement accuracy of the reflection coefficient is dependent on the following factors:

- Bi-directional coupler directivity (power level difference between the coupled and isolated ports) and coupling difference (power lost to the coupled and isolated ports) between forward and reflected signal ports
- Gain imbalance between forward and reflected power inputs of the measurement receiver

- Isolation (power level difference) between the forward and reflected power pins of the measurement receiver (minimum value 30 dB)
- Isolation between transceiver output and measurement receiver inputs (minimum value 50 dB)
- Isolation from antenna to the input pins of measurement receiver (minimum value 80 dB)
- Interfering signals from WLAN - Third harmonic from WLAN signal can sometimes be down-converted by the local oscillator of measurement receiver to baseband on top of measured transmitted signal in the MRx mixer.

The above error sources have a worse effect on the reflected power measurements since power level is generally lower there. That is why it is important to calibrate the measurement receiver and to determine its dynamic range before starting the antenna tuning activity.

## 4 Performance and measurements

Since the objective of this thesis work is to develop an antenna tuning system that can be included in a commercial mobile platform, the method chosen to determine the performance of such a system, is based on actual measurement rather than on simulation [33]. This section describes the antenna tuning system that was actually implemented in the lab using the hardware components and measuring instruments provided by ST-Ericsson. The test set-up is also explained in detail. Finally the measurement results of this exercise are presented and a discussion on the results follows.

### 4.1 Implementation and measurement set-up

Several limitations came up during the course of implementation of the antenna tuning system. This sub-section describes the choices made in the implementation and measurement set-up in the wake of these limitations and in order to prevent the volume of measurements from becoming too huge to be feasibly carried out in the given time frame.

#### 4.1.1 Chosen control algorithm

In the course of implementing the reflection coefficient calculation block, it was realized that the accuracy of phase measurements for the transmitted and reflected signal done by measurement receiver used in the project, is not good enough. A lot of variation was observed in the phase readings between two consecutive measurements when all other factors were constant. In the beginning the hardware designers of the measurement receiver attributed this behavior to the lack of proper time alignment between the transmitted/reflected signal and the reference signal but a sweep done on the possible time alignment values did not show any improvement in the oscillating phase values. Investigation on this behavior continues but for the purpose of this thesis work, it was decided to abandon the use of phase in impedance calculation and to formulate a tuning algorithm with the knowledge of the amplitude of transmitted and reflected signals. With this limitation it was not possible to use the Equation Based or the Gradient Control algorithms. Most of the previous research done on this subject [34] [35], showed that it is possible to have good performance from an antenna tuning system with the approach used in the Hill Climbing algorithm. Hence this algorithm was the default choice.

The possible configurations of the three capacitances or the HVDAC voltages of the STM Paratek antenna tuner can be visualized as a three dimensional coordinate space. The tuning algorithm implemented for this thesis work, starts from the center of this space and explores the behavior of six nearest neighbors. The magnitude of reflection coefficient is compared for all these locations with reference to the current one and slopes are computed. The reference point then moves to the location with maximum slope. This search continues in a sequential manner with the reference point moving along the direction exhibiting best reduction in reflection coefficient

magnitude until the reference point does not change any more. There is a high probability that this point would be a local minima but in the absence of information about the phase of the transmitted and the reflected signal, this approach yields relatively the best possible results.

#### 4.1.2 Chosen antenna parameters

Antenna parameters (impedance, VSWR, return loss etc.) depend on the antenna condition and the frequency of usage. The different types of scenarios that would determine the antenna condition are as follows:

- Free space: Mostly applicable for hands-free mode
- Head and hand: The phone is held against the head with a hand
- Finger: The phone is held against the head with a hand and with a finger covering part of the antenna
- Only head: The phone is held against the head without a hand but with an elastic band or tape

Each of the above scenarios can produce different antenna impedance depending on its design and frequency of usage. Since the intention of this thesis work is to develop and test an antenna tuning system that is as flexible as possible, we decided to refrain from measuring the effectiveness of tuning for a specific antenna. Instead, looking the broad range of data available from different antenna designs, it was clear that the VSWR of an average antenna varies between 1:2 to 1:7 for different conditions. Hence it was decided to carry out the measurements for several mismatch values along this range of VSWR. Also it is important to take the phase shift into account since it is not necessary that the antenna tuner system is able to tune equally well on all the angles from 0 to 360 degrees. So we decided to measure on one central point for each of the four quadrants of Smith Chart.

#### 4.1.3 Chosen frequencies

Once the antenna tuning algorithm is implemented and the antenna parameters are chosen, it is time to choose the frequencies for which the impedance matching will be done with the antenna parameters given above. At the time of the execution of this thesis work there are no automated measurement tools available in ST Ericsson for the antenna tuning set-up. So each measurement has to be done manually and is quite time consuming. So in order to keep the time schedule of this project, it was decided to implement and test antenna tuning for WCDMA only. The radio module used in our set-up supports five bands out of which three are in high frequency range and the other two have low frequency. For carrying out the measurements, band 1, Tx channel 9750 in the high band range and band 8, Tx channel 2788 in the low band range were selected. In spite of the limited set of measurements, the chosen bands and channels are such that it is possible to get a fair idea about the behavior of antenna tuning over a range of frequencies.

## 4.2 Lab set-up

The lab setup used for carrying out the measurements with the antenna tuning system is shown in Figure 31. The cables and transmission lines in between the different units of this setup introduce a phase shift which changes the impedance in an arbitrary way. This is undesired since the key requirement behind antenna tuning is the reproducibility of its results. Hence care is taken that the same set of cables are used in the setup from beginning to end and that these cables are also included while calibrating the measuring devices. A short description of each of the elements used in the setup is given below.

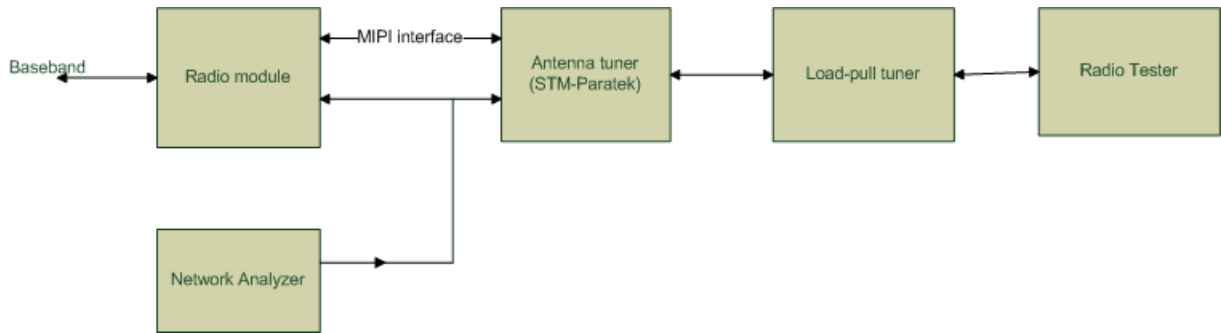

Figure 31: Lab set-up

### 4.2.1 Radio module and antenna tuner

The radio transceiver used in this thesis work consists of two processors, a CPU called STxP70 executing at a frequency clock of 208 MHz and a simple Sequencer executing at 52 MHz. It has a Digital Front End block that interfaces with the baseband and an Analog Front End block that up-converts the signal to RF frequency for uplink and down-converts to baseband frequency for downlink. Both blocks are separated by a Digital to Analog converter. The radio module is mounted on a cradle that also consists of a MIPI connector on which the Antenna tuner provided by STM-Paratek, is plugged. The tuner module is provided with two SMA (coaxial RF) connectors for Main and Diversity antenna. The transceiver is calibrated without the antenna tuner so that the insertion loss introduced by the tuner is visible in the form of reduced output power in case of a perfect match.

### 4.2.2 Load-pull tuner

A load-pull tuner is a sliding mechanical installation actuated by stepper motors to realize variable load or source impedances to any circuit. In our antenna impedance tuning setup, the load-pull tuner is used to simulate the antenna impedance. This instrument and its tuning is controlled by the software that takes the effective impedance point on a smith chart as input and tunes the mechanical components of the load pull tuner to provide the required magnitude and phase shift in the

impedance. Hence the variability in the antenna impedance can be effectively simulated by tuning the load pull tuner to different impedance points on all the four quadrants of the smith chart. Before starting the usage, the instrument along with the cables needs to be carefully calibrated with network analyzer for the required range of frequencies.

### 4.2.3 Network Analyzer

Network Analyzer is an instrument that is used to measure network parameters of an electronic circuit. This device is able to separate forward wave and reflected wave from an antenna. Thereafter it measures the magnitude and phase of transmitted and reflected signals and hence calculates S-parameters at any frequency range. Before starting any measurement with the network analyzer it is necessary to calibrate it using the standard open, short and matching loads. In our setup the network analyzer is initially used to calibrate the load-pull tuner and then to measure the S11 and the return loss after the tuner finds the best possible match to compensate an impedance mismatch. The Smith Chart plotted by the device for the impedance mismatch before and after tuning, is also very useful in providing a graphical view of the tuner behavior.

### 4.2.4 Radio Tester

The Radio Tester acts as base station for the radio module of the cellular terminal. It enables the measurement of output power, EVM and ACLR at the antenna interface of the radio module.

## 4.3 Measurement results

### 4.3.1 VSWR and S11

S11 parameter represents the amount of reflected power from the antenna and hence is a measure of the quality of impedance match between the antenna and the radio module that the antenna tuner has been able to achieve. In our setup we measure the magnitude of S11, also known as Return Loss, in dB, after the adaptive antenna tuning process, for a range of load impedances. A Return Loss value of less than -10 dB is considered as acceptable performance for a radio module since this indicates a sufficiently low reflected power. S11 can be measured with Network Analyzer at the output of radio module. Measuring the transmitted and reflected powers from the measurement receiver (using the firmware inside the radio module) and then subtracting the two, also yields the S11 or Return Loss. Ideally the two values should be the same but this is rarely the case due to imperfections in the front end module design and also due the limited dynamic range of measurement receiver. Nevertheless it is useful to carry out the measurement in both ways. The measurement results are given in Table 2 and 3 for 1950 MHz and in Table 4 and 5 for 897.6 MHz.

Table 2: S11 measured with Network Analyzer before and after tuning for 1950 MHz

VSWR	Return Loss before tuning(dB)	Return Loss after tuning(dB)	VSWR after tuning
1:2	-9.2	-9.8	1:1.95
1:3	-5.9	-8.74	1:2.1
1:4	-4.4	-8.1	1:2.2
1:5	-3.6	-6.5	1:2.7
1:6	-2.8	-7.3	1:2.5
1:7	-2.9	-7.11	1:2.5

Table 3: S11 measured from Measurement Receiver before and after tuning for 1950 MHz

VSWR	Return Loss before tuning(dB)	Return Loss after tuning(dB)
1:2	-5	-22.5
1:3	-1	-21.56
1:4	0	-24.38
1:5	0	-22.75
1:6	0	-20.45
1:7	0	-19.69

### 4.3.2 Output power

The output power from the radio module is measured for different antenna impedances (simulated with different VSWR values on the load-pull tuner) before and after the adaptive antenna tuning. The measurement of output power before tuning is done without the antenna tuner so that the insertion loss of the antenna tuner is not included. This is done to give an accurate picture of the deterioration of output power with increasing VSWR of the antenna and the exact improvement when adaptive tuning is used. Maximum output power is requested by the radio tester but due to cable losses, the maximum output power measured, without the antenna tuner and with an antenna impedance of 50 ohms, is around 22 dBm. The observations for 1950 MHz and 897.6 MHz are given in the Tables 6 and 7 respectively.

In the above cases, the magnitude of load impedance was varied but the phase was constant so that the impedance of the antenna was always in the same quadrant of Smith chart. Next, the measurement of output power on 1950 MHz was done for different phase values of the load impedances while keeping the magnitude of load impedance fixed to a VSWR of 1:7. The observations recorded are plotted in the Figure 32.

### 4.3.3 EVM and ACLR

EVM and ACLR measurements provide important information on the linearity of power amplifier and front end modules. Measurement of these parameters before and after antenna tuning was done as part of this thesis work. Minor change of  $\pm 0.5\%$  was observed in the EVM values and there was always a good margin to the

Table 4: S11 measured with Network Analyzer before and after tuning for 897.6 MHz

VSWR	Return Loss before tuning(dB)	Return Loss after tuning(dB)	VSWR after tuning
1:2	-9.2	-10.8	1:1.8
1:3	-5.9	-12.48	1:1.6
1:4	-4.5	-10.86	1:1.8
1:5	-3.5	-21.1	1:1.2
1:6	-2.9	-16.0	1:1.37
1:7	-2.5	-13.4	1:1.5

Table 5: S11 measured from Measurement Receiver before and after tuning for 897.6 MHz

VSWR	Return Loss before tuning(dB)	Return Loss after tuning(dB)
1:2	-5	-10.8
1:3	-3	-10.0
1:4	-1	-10.86
1:5	0	-12.25
1:6	0	-12.20
1:7	0	-8.725

3GPP requirements. For ACLR, the observations for 1950 MHz are shown in the Figure 33. It is clear from the plot that there is no major change in the ACLR values both for  $\pm 5$  MHz and  $\pm 10$  MHz and the values are well under the limit specified by 3GPP.

#### 4.4 Analysis

Looking at the measurement data given above, it is obvious that antenna tuning brings about improvement in the radiated power and return loss in impedance mis-

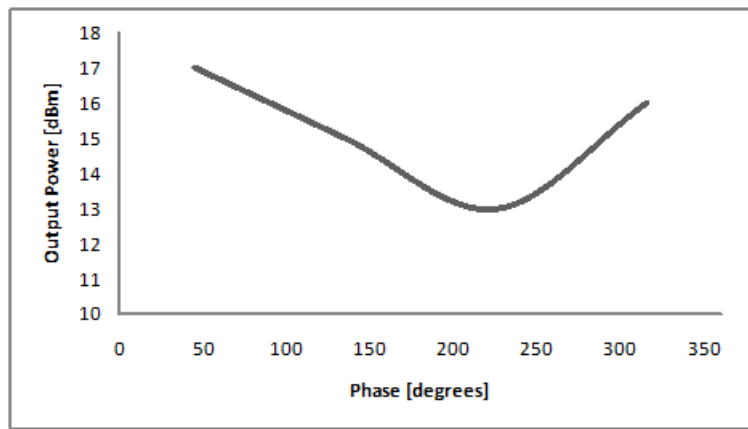

Figure 32: Output power vs phase of load impedance

Table 6: Output power before and after tuning for 1950 MHz

VSWR	Output power before tuning(dBm)	Output power after tuning(dBm)
1:1	21.6	20.7
1:2	20.1	20.0
1:3	18.6	19.5
1:4	17.4	19.0
1:5	16.3	18.3
1:6	16.3	17.3
1:7	13.1	17.6

Table 7: Output power before and after tuning for 897.6 MHz

VSWR	Output power before tuning(dBm)	Output power after tuning(dBm)
1:1	22.1	20.8
1:2	20.4	19.5
1:3	19.1	19.4
1:4	18.6	19.0
1:5	17.9	19.2
1:6	17.1	18.9
1:7	16.7	19.4

match conditions. However there are some peculiarities in this behavior that are analyzed here.

One strange observation is that in high band measurements there is a large difference in the Return Loss that is measured from the network analyzer and the one returned from the measurement receiver after tuning. Ideally these values should

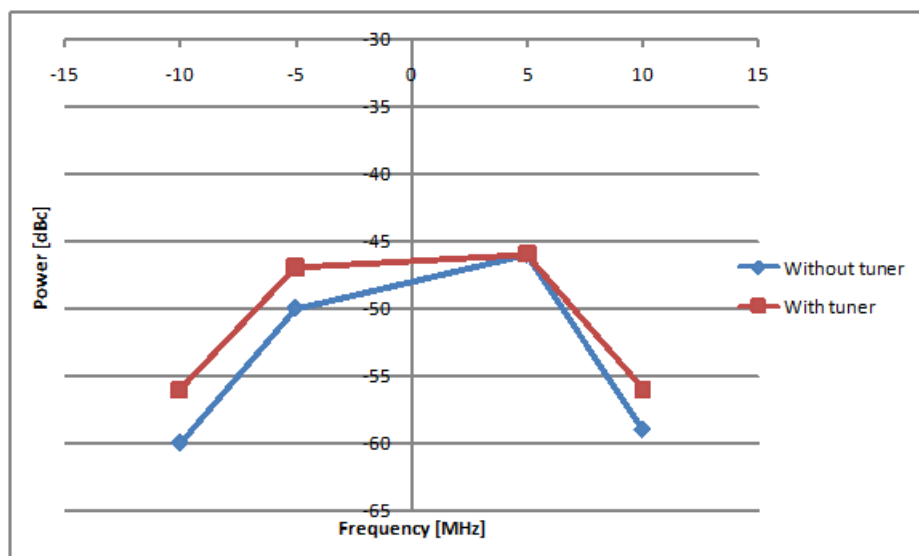

Figure 33: ACLR for 1950 MHz

be almost the same as is the case in low band measurements. Also the VSWR value measured after tuning, with network analyzer, is not all that good. A possible explanation for this behavior is that the network analyzer measures the quality of impedance match with respect to 50 ohm impedance. On the other hand, the front end design of the radio module consists of several switches, filters, resistors etc. Great effort is made to ensure that the front end is well matched to the ideal antenna impedance of 50 ohm but at times the layout design introduces errors and the radio module is terminated at an erroneous reactance instead of the ideal 50 ohm load. This leads to a condition where antenna tuner system is able to match the non ideally terminated radio platform to the previously mismatched antenna which reflects in the improvement of output power level and in the return loss measured by the measurement receiver but the measurement done by network analyzer still shows a mismatch.

Analysis of measurement data highlights another important fact that the antenna tuner module introduces an insertion loss thus reducing the power at a perfect 50 ohm match. Though the documented value of this insertion loss as given by the manufacturer of the antenna tuner is between 0.5 and 1dB, the measurements done as part of this thesis work show that in WCDMA low band, the insertion loss can reach up to 2dB. So there is a definite deterioration in performance of radio module in perfect match conditions when using the antenna tuner. However, the perfect match condition rarely occurs not just because of the antenna usage but also because it is very difficult to design an antenna that would provide a 50 ohm termination across the wide range of frequencies that are commonly used in mobile handsets nowadays. The situation can be further improved if the open loop settings are chosen such that the antenna tuner introduces minimum insertion loss. Thereafter the closed loop can choose a configuration that minimizes the reflected power. In this way the Antenna tuning system will deteriorate the performance a little when the impedance match is almost good but as shown in the results above, it will improve the performance substantially as the matching condition worsens.

Another aspect that is visible in the above results is that the STM-Paratek antenna tuner does not tune equally well on all the four quadrants of Smith Chart. For example, in WCDMA high band, tuning is the best in first quadrant (centered around 45 degrees), acceptable in second and fourth quadrant and worst in the third quadrant. This behavior has been deliberately designed by the antenna tuner manufacturer since according to their research, the effective antenna impedance in common usage of a mobile device has a higher probability of falling in those quadrants of Smith chart where the performance of tuning is better than others.

For EVM and ACLR, there is no major change in the measured values before and after tuning in case of a mismatch. This was contrary to expectations but analysis shows that there is an explanation for this behavior. On one hand, the improvement in the antenna impedance match, because of tuning, should improve the linearity of the power amplifier which in turn should improve the EVM and the ACLR of the radio system but on the other hand, the antenna tuner itself is non-linear device. Hence the improvement in PA linearity is probably compensated by the deterioration in linearity due to the addition of antenna tuner hardware.

However, if a radio platform is designed from the beginning with an antenna tuner, then the bias settings of the power amplifier can be substantially reduced since it would then be unnecessary to have a large margin for the ACLR compared to the specifications. This would result in a radio platform that can perform equally well with a less linear power amplifier, thus saving the current consumption.

## 5 Conclusion

As the current trend of including more and more functionality in the mobile handsets continues to grow, the task to fit all the necessary peripheral devices along with the antennas of different wireless technologies in the least possible size, becomes extremely challenging. This results in a non-optimal design of the radio module and compromises in the position of the antenna. Also a single antenna is expected to cover a wide range of frequency bands. Naturally, these factors lead to a degradation in the performance of the antenna. On the other hand, the ever increasing demand for higher data rates, robust communication and minimal power consumption, does not leave any window for performance degradation.

The performance degradation is mainly caused by the impedance mismatch between the antenna and the radio module. Mismatch might occur due to the design, shape and position of the antenna but the main cause is the surroundings of the antenna and its usage. Antenna's contact with human body, i.e. when the mobile device is held between head and hand or when finger is moved around it, can change its impedance substantially. Also, the environmental factors, i.e whether the mobile device is held in free space or lying on a metallic surface, contribute to the change in antenna impedance. This impedance mismatch leads to power loss as part of the transmitted power is reflected back. Such mismatch losses are undesired as they shorten the talk time, degrade the receiver sensitivity and cause spurious emissions to adjacent channels.

This thesis work addresses the issue of impedance mismatch in radio sub-system and proposes a solution in the form of adaptive or closed loop antenna tuning. The concept of antenna tuning requires the insertion of a Pi or T shaped LC network with tunable reactance that can be changed based on the feedback about antenna impedance. Such an LC network with variable capacitances, based on BST technology, designed by STM-Paratek, is used in this project to develop the antenna tuning system.

### 5.1 Summary

After a brief introduction to the impedance mismatch phenomenon in modern wireless devices, its causes and adverse effects, this thesis starts off with a detailed theoretical background on the subject of impedance matching in electrical circuits. Some of the commonly used impedance matching circuits like T or Pi shaped LC networks, binary capacitance array network, are described with mathematical equations and figures. More details are given for the Pi-network that is used in the implementation of antenna tuning system later on. Measurement parameters that are used to quantify the quality of impedance match are also introduced here. Next, a very brief description about antenna fundamentals is included. The commonly used types of antennas in the wireless handsets nowadays, their design issues and performance parameters are presented. The thesis then moves on to describe the basic building blocks, both hardware and software that are used in developing an antenna tuning system. The hardware elements include bidirectional coupler and

measurement receiver to measure the transmitted and reflected power from the antenna, an antenna tuner with variable capacitors controlled by HVDACs, a processor or micro-controller to execute the tuning control algorithm and the MIPI RFFE interface between the processor and antenna tuner. Information given here is in the context of the system developed as part of this thesis work but it is in fact quite general and applicable to any radio module around which an antenna tuning system is designed.

The software elements consist of a reflection coefficient tracking module that is responsible for interfacing with the measurement receiver to measure and calculate the reflection coefficient, an impedance calculation module that decides the new configuration of the antenna tuner module after receiving the reflection coefficient update, a MIPI RFFE driver module that is in charge of the physical control of the antenna tuner module and a common control module that runs the state machine of the adaptive antenna tuner system. The design and implementation details of each of the above blocks are described later. The reflection coefficient tracking block negotiates the availability of measurement receiver with the internal power control algorithm that has a higher priority because of its timing accuracy requirement. Once available, the measurement receiver is instructed to measure the magnitude and phase of the transmitted and reflected power which is then used to calculate the reflection coefficient. This information is then passed to the impedance calculation module.

Since the algorithm that calculates the configuration of the antenna tuner for the best possible impedance match, is the key to the performance of the adaptive antenna tuning system, a few possibilities were studied and analyzed in this thesis. One such algorithm is based on the equations of a Pi-network with three variable capacitors. This approach is very efficient since it finds the new configuration of antenna tuner in only a few iterations but it demands highly accurate measurement of reflection coefficient and is not flexible with respect to the changing track lengths and PCB traces that are difficult to avoid in a real life hardware design. Another algorithm that was studied in this thesis is based on gradient control. There are two possible approaches that can be followed in this algorithm. One approach requires characterization of the behavior of the three tunable capacitors with respect to the impedance match, calculating the coefficients of their respective gradients and storing them in permanent memory. The other approach tries to avoid the extensive measurement session in the lab by calculating the gradient adaptively during the tuning process. Both approaches are quite flexible and are more and less guaranteed to converge to a good match but there is a risk of running into a local minima. The third algorithm studied in this thesis is a version of adaptive local search algorithm also known as Hill Climbing. The idea followed in this case is to take small steps in the three dimensional coordinate space and move to the point that gives the best results compared to the other options. The simplicity and flexibility offered by this approach is immense. It is also very accommodating for the inaccuracies of measurement system and faults in the radio module design. Downside is longer settling time and high probability of converging to a local minima.

The Common control block is responsible for deciding whether the antenna tun-

ing system works in Open loop, Closed loop or Broken loop mode and for controlling the transitions between these modes. The decision is based on the power level, the extent of impedance mismatch and the accuracy of measurement receiver results. At the starting point, the antenna tuner is always configured on the basis of Open Loop settings relevant for the operational frequency, retrieved from the permanent memory. If the power level is high enough and the impedance mismatch as determined from the reflection coefficient measurement, is worse than a benchmark, transition is made to Closed Loop i.e. the antenna tuner configuration is changed adaptively until a satisfactory impedance matching is obtained. Broken Loop mode comes into effect if the accuracy of measurement receiver results is unacceptable so that the antenna tuner configuration is not changed any more until the measurement results are reliable.

After describing the design of the software modules, the thesis then goes on to discuss the implementation intricacies of antenna tuner system in different RATs with respect to their timing constraints and impact on other blocks of the transceiver chain. The steps taken to mitigate the possible adverse effects of introducing antenna tuning on the functionality of RATs are also discussed. Also included here is a description of the performance degradation scenarios that are associated with the use of antenna tuner. Examples of such scenarios are loss in the output power in a perfect match due to the insertion loss introduced by the antenna tuner hardware, degradation in EVM and ACLR of the signal due to the non-linear effects of the capacitors in antenna tuner and the possibility of converging to an incorrect configuration due to inaccurate results from the measurement receiver. None of these effects can be completely avoided or compensated but an effort is made in this thesis work to measure these parameters carefully and take into account when analyzing the results.

During the actual implementation of the antenna tuner system, several limitations came up due to the performance of the radio module available at hand. It was realized during the characterization of measurement receiver, that the phase measurements were too noisy i.e. there was a lot of variation between two consecutive measurements of phase values of transmitted and reflected powers. This lack of reliability of phase measurements forced the development of the antenna tuner system based on just the magnitude of transmitted and reflected power. Hence Hill Climbing algorithm was chosen for this thesis work. In addition, a VSWR of 2 to 7 and WCDMA band 1 (mid-channel) and 8 (mid-channel) were chosen to carry out the measurements in order to complete the project in a realistic time-frame. Thereafter, the lab setup for carrying out the measurements is described. Load-pull tuner is used to simulate the antenna impedance and Network Analyzer is used to measure the S11 parameters after the antenna tuner has converged to a configuration that is optimum for the given mismatch while a Radio tester is used to measure the output signal for power, EVM and ACLR. The measurement results that presented in the thesis later show a clear improvement in output power and PA efficiency when adaptive antenna tuning is used. This improvement gets more and more substantial as the impedance match worsens. However, there was not much effect on the EVM and ACLR measured values with or without antenna tuning.

## 5.2 Discussion

The idea of adaptive antenna tuning is now gaining momentum with most mobile phone and chipset manufacturers. The availability of tunable reactive components that can be integrated in electronic circuits along with better accuracy in the measurements done by bidirectional couplers, have cleared the way for introducing this technology at commercial scale. As shown by the results of this thesis work, the antenna tuner does introduce an insertion loss so the performance deteriorates by a small measure in perfect match case but in most other cases when the antenna impedance varies and mismatch increases, the antenna tuner improves the performance more than it deteriorates. The most obvious improvement in performance is in the form of output or Total Radiated Power. The improvement in output power has a direct relationship with PA efficiency and is reflected in lower current consumption by the power amplifier which in turn results in longer talk time. Moreover, the remarkable reduction in amount of reflected power with antenna tuning, protects the front end components from being damaged thus removing the necessity of an isolator. The noise floor of the receiver also improves as standing wave magnitude gets reduced thus enhancing its Total Isotropic Sensitivity. In addition, the design of front end module including the antenna can be much more relaxed as the stringent requirements of preserving a reasonable impedance match over a large range of frequencies is no longer required.

## 5.3 Future Work

This thesis work provides a proof-of-concept of an adaptive antenna tuner system in a commercial product. It also provides the building blocks and a recommended architecture for such a system. However, there are still several things to be done before an adaptive antenna tuner, integrated inside a commercial mobile handset, becomes a reality. Some of the points that still remain unexplored are as follows:

- Reliable phase measurement: Once the measurement receiver is characterized and is able to deliver reliable phase measurement values for transmitted and reflected power, more complex tuning algorithms can be used. The algorithms described in section 3.2 are good candidates for this. It is very likely that the accuracy of impedance match would be much better when phase information is also taken into account. Hence better results can be expected from antenna tuning system than those presented in this thesis work.
- Automated system for determining open loop settings with minimum insertion loss: In order to ensure fast convergence of the antenna tuning algorithm in mismatch conditions and also to prevent large changes in power levels, it is important to start with optimum open loop settings for operational frequency. In addition, the open loop settings should ensure the minimum insertion loss for the antenna tuner. An automated tool that would conduct a global search of all the antenna tuner settings to determine the best possible configuration for the given frequency range, is required to meet the above targets.

- Compromise between Tx and Rx: This thesis work has concentrated on getting optimal adaptive antenna tuning performance for radio transmission. Hence the closed loop tuning algorithm works on transmitting frequency. But in WCDMA where transmission and reception are active at the same time on different frequencies, the antenna tuner configuration that is best for transmission might not be the best for reception especially in case of bands where the two frequencies are separated by a large gap (WCDMA band 4). This aspect should be tested and a compromise on antenna tuning configuration should be found if the reception performance is found unsatisfactory.
- MIMO and Carrier Aggregation: Multiple antenna techniques like MIMO (Multiple Input Multiple Output) and carrier aggregation are going to be a part of commercial handsets soon. Integrating antenna tuner with multiple antennas would be rather challenging as the system will become quite complex. It needs to be studied if it would be better to use separate antenna tuners for different antennas or to implement antenna tuner system for only the main antenna or to design the front end module in such a way that the antenna tuner can be dynamically switched between the antennas with the help of switches. Each of these options has its own advantages and disadvantages. So a systematic study is required to find a good solution.

## References

- [1] M. Feng, Shyh-Chiang Shen, D.C. Caruth and J.J. Huang, *Device Technologies for RF Front-End Circuits in Next-Generation Wireless Communications*, in Proc. IEEE, Vol. 92, No. 2, pp. 354-375, February 2004.
- [2] Andre van Bezooijen, Reza Mahmoudi and Arthur H. M. van Roermund, *Adaptive Methods to Preserve Power Amplifier Linearity Under Antenna Mismatch Conditions*, IEEE Transactions on Circuits and Systems, Vol. 52, No. 10, pp. 2101-2108, October 2005.
- [3] Qizheng Gu, *RF System Design of Transceivers for Wireless Communications*, Springer, New York, 2005.
- [4] Jesus de Mingo, Antonio Valdovinos and Alfredo Crespo, *Input Impedance Antenna Automatic Matching System*, in Proc. IEEE International Symposium Personal, Indoor and Mobile Radio Communications, pp. 1872-1876, September 2002.
- [5] Fanfan Meng, Andre van Bezooijen, and Reza Mahmoudi, *A Mismatch Detector for Adaptive Antenna Impedance Matching*, in Proc. European Microwave Conference, pp. 1457-1460, September 2006.
- [6] Papapolymerou. J., Lange. K., Goldsmith. C., Malczewski. A. and Kleber. J., *Reconfigurable double-stub tuners using MEMS switches for intelligent RF front ends*, IEEE transactions on Microwave Theory and Techniques, Vol. 51, No. 1, pp. 271-278, January 2003.
- [7] Amro M. Elshurafa and Ezz I. El-Masry, *Tunable Matching Networks for future MEMS based transceivers*, in Proc. International Symposium Circuits and Systems, Vol. 4, pp. 457-460, May 2004.
- [8] L.Y. Vicki Chen, Roger Forse, D. Chase, and Robert A. York, *Analog Tunable Matching Network Using Integrated Thin-Film BST Capacitors*, IEEE International Microwave Symposium Digest, Vol. 1, pp. 261-264, June 2004.
- [9] Peregrine Semiconductor, *DuNE Digitally Tunable Capacitors*, June 2012, available [http://www.psemi.com/pdf/sell\\_sheet-psg/73-0039.pdf](http://www.psemi.com/pdf/sell_sheet-psg/73-0039.pdf).
- [10] Luyi Liu and Richard Langley, *Electrically small antenna tuning techniques*, in Proc. Antennas and Propagation Conference, pp. 313-316, November 2009.
- [11] Andre van Bezooijen, Maurice A. de Jongh, Freek van Straten, Reza Mahmoudi and Arthur H. M. van Roermund, *Adaptive Impedance-Matching Techniques for Controlling L Networks*, IEEE Transactions on Circuits and Systems, Vol. 57, No. 2, pp. 495-505, February 2010.

- [12] Ronald Davidson, *Transfer Unit for Radio Frequency Signals and Method for Alternatively Using an Electrical Antenna or a Magnetic Antenna with a Classic Antenna Tuner*, United States Patent Application 20110273354, <http://www.freepatentsonline.com/y2011/0273354.html>.
- [13] Andre van Bezooijen, Maurice A. de Jongh, Christophe Chanlo, Lennart C. H. Ruijs, Freek van Straten, Reza Mahmoudi and Arthur H. M. van Roermund, *A GSM/EDGE/WCDMA Adaptive Series-LC Matching Network Using RF-MEMS Switches*, IEEE Journal of Solid-State Circuits, Vol. 43, No. 10, pp. 2259-2268, October 2008.
- [14] Constantine A. Balanis, *Antenna Theory: Analysis and Design*, 3rd edition, Wiley, 2005.
- [15] Ahmed A. Kishk, *Fundamentals of Antenna*, Mc Graw Hill, 2009.
- [16] Agilent Technologies, *Directional Coupler Overview*, [http://www.home.agilent.com/upload/cmc\\_upload/All/Direct\\_CouplerOverview.pdf](http://www.home.agilent.com/upload/cmc_upload/All/Direct_CouplerOverview.pdf).
- [17] MIPI Alliance, *MIPI RF Front end specifications*, <http://www.mipi.org/specifications/rf-front-end>.
- [18] Qizheng Gu, Javier R. De Luis, Arthur S. Morris and Jeff Hilbert, *An Analytical Algorithm for Pi-Network Impedance Tuners*, IEEE Transactions on Circuits and Systems I, Vol. 58, No. 12, pp. 2894-2905, December 2011.
- [19] Zeldia B. Zabinsky, *Random Search Algorithms*, in Wiley Encyclopedia of Operations Research and Management Science, John Wiley and Sons, 2011.
- [20] Koichi Ogawa, Tsukasa Takahashi, Yoshio Koyanagi and Koichi Ito, *Automatic Impedance Matching of an Active Helical Antenna Near a Human Operator*, in Proc. European Microwave Conference, Vol. 3, pp. 1271-1274, October 2003.
- [21] R. J. M. Vaessens, E. H. L. Aarts and J. K. Lenstra, *A local search template*, Computers and Operations Research, Vol. 25, No. 11, pp. 969-979, November 1998.
- [22] Sean Luke, *Essentials of Metaheuristics*, A Set of Undergraduate Lecture Notes, Department of Computer Science, George Mason University, February 2012.
- [23] Daigo Muramatsu, *Online Signature Verification Algorithm Using Hill-Climbing Method*, in Proc. IEEE International Conference on Embedded and Ubiquitous Computing, Vol. 2, pp. 133-138, December 2008.
- [24] Francisco Javier Ovalle Martínez, Julio Solano Gonzalez and Ivan Stojmenovic, *A parallel hill climbing algorithm for pushing dependent data in clients-providers-servers systems*, in Proc. International Symposium on Computers and Communications, pp. 611-616, November 2002.

- [25] Renjeng Su and Nouredine Kermiche, *A learning scheme for open-loop and closed-loop control*, in Proc. IEEE International Symposium on Intelligent Control, pp. 523-528, August 1988.
- [26] Shen Jianhe, Chen Shuhui and Cai Jianping, *An Open-plus-closed-loop Control for chaotic Mathieu-Duffing Oscillator*, in Proc. Chinese Control Conference, pp. 492-496, July 2007.
- [27] Robert Müllner, Carsten F. Ball, Kolio Ivanov, Johann Lienhart and Peter Hric, *Contrasting Open-Loop and Closed-Loop Power Control Performance in UTRAN LTE Uplink by UE Trace Analysis*, in Proc. IEEE International Conference on Communications, pp. 1-6, June 2009.
- [28] Jin Lu and Lyndon J. Brown, *A combination of open and closed-loop control for disturbance rejection*, in Proc. Canadian Conference on Electrical and Computer Engineering, pp. 563-568, May 2011.
- [29] Howard T. Russell, *A Loop-Breaking Method for the Analysis and Simulation of Feedback Amplifiers*, IEEE Transactions on Circuits and Systems I, Fundamental Theory and Applications, Vol.49, No. 8, pp. 1045-1061, August 2002.
- [30] Rob Kopmeiners, *Time Accurate Control of RF over a DIGRF Interface*, United States Patent Application 20100074311, <http://www.freepatentsonline.com/y2010/0074311.html>.
- [31] Johan Bergman, Mårten Ericson, Dirk Gerstenberger, Bo Göransson, Janne Peisa and Stefan Wager, *HSPA Evolution Boosting the performance of mobile broadband access*, Ericsson Review, No 1, 2008.
- [32] Ranjit Gharpurey, *Managing Linearity in Radio Front-Ends*, in Proc. IEEE Custom Integrated Circuits Conference, pp. 1-8, September 2011.
- [33] Ichirou Ida, Jun-ichi Takada, Takeshi Toda and Yasuyuki Oishi, *An Adaptive Impedance Matching System and its application to Mobile Antennas*, in Proc. IEEE Region 10 Conference (TENCON), Vol. 3, pp. 543-546, November 2004.
- [34] Jesus de Mingo, Antonio Valdovinos, Alfredo Crespo, Denis Navarro and Paloma Garcia, *An RF Electronically Controlled Impedance Tuning Network Design and Its Application to an Antenna Input Impedance Automatic Matching System*, IEEE Transactions on Microwave Theory and Techniques, Vol. 52, No. 2, pp. 489-497, February 2004.
- [35] Luke Sankey and Zoya Popovic, *Adaptive Tuning for Handheld Transmitters*, International Microwave Symposium Digest, pp. 225-228, June 2009.