This is an electronic reprint of the original article.
This reprint may differ from the original in pagination and typographic detail.

Author(s): Lamminmäki, Satu & Mandel, Anne & Parkkonen, Lauri & Hari, Riitta
Title: Binaural interaction and the octave illusion
Year: 2012
Version: Final published version

Please cite the original version:

Lamminmäki, Satu & Mandel, Anne & Parkkonen, Lauri & Hari, Riitta. 2012. Binaural interaction and the octave illusion. The Journal of the Acoustical Society of America. Volume 132, Issue 3. 1747-1753. ISSN 1520-8524 (electronic). DOI: 10.1121/1.4740474.

Rights: © 2012 Acoustical Society of America (ASA). This is the accepted version of the following article: Lamminmäki, Satu & Mandel, Anne & Parkkonen, Lauri & Hari, Riitta. 2012. Binaural interaction and the octave illusion. The Journal of the Acoustical Society of America. Volume 132, Issue 3. 1747-1753. ISSN 1520-8524 (electronic). DOI: 10.1121/1.4740474, which has been published in final form at <http://scitation.aip.org/content/asa/journal/jasa;jsessionid=8495apccp7p7.x-aip-live-06>.

All material supplied via Aaltodoc is protected by copyright and other intellectual property rights, and duplication or sale of all or part of any of the repository collections is not permitted, except that material may be duplicated by you for your research use or educational purposes in electronic or print form. You must obtain permission for any other use. Electronic or print copies may not be offered, whether for sale or otherwise to anyone who is not an authorised user.

Binaural interaction and the octave illusion

Satu Lamminmäki,^{a)} Anne Mandel, Lauri Parkkonen, and Riitta Hari^{b)}

Brain Research Unit, O.V. Lounasmaa Laboratory, School of Science, Aalto University,
P.O. Box 15100, FI-00076 AALTO, Espoo, Finland

(Received 30 March 2012; revised 26 June 2012; accepted 2 July 2012)

The auditory octave illusion arises when dichotically presented tones, one octave apart, alternate rapidly between the ears. Most subjects perceive an illusory sequence of monaural tones: A high tone in the right ear (RE) alternates with a low tone, incorrectly localized to the left ear (LE). Behavioral studies suggest that the perceived pitch follows the RE input, and the perceived location the higher-frequency sound. To explore the link between the perceived pitches and brain-level interactions of dichotic tones, magnetoencephalographic responses were recorded to 4 binaural combinations of 2-min long continuous 400- and 800-Hz tones and to 4 monaural tones. Responses to LE and RE inputs were distinguished by frequency-tagging the ear-specific stimuli at different modulation frequencies. During dichotic presentation, ipsilateral LE tones elicited weaker and ipsilateral RE tones stronger responses than when both ears received the same tone. During the most paradoxical stimulus—high tone to LE and low tone to RE perceived as a low tone in LE during the illusion—also the contralateral responses to LE tones were diminished. The results demonstrate modified binaural interaction of dichotic tones one octave apart, suggesting that this interaction contributes to pitch perception during the octave illusion.

© 2012 Acoustical Society of America. [http://dx.doi.org/10.1121/1.4740474]

PACS number(s): 43.75.Cd, 43.64.Qh, 43.66.Pn, 43.66.Rq [DD]

Pages: 1747–1753

I. INTRODUCTION

Although illusions may seem just faulty sensory percepts, they can inform about normal neurophysiology and its limits.

The auditory octave illusion, first described by Deutsch (1974), arises when subjects are presented with dichotic tone pairs separated by an octave (e.g., a 400-Hz tone to one ear and an 800-Hz tone simultaneously to the other ear), and the location of the tones reverses rapidly (e.g., after each 250 ms) between the two ears (Fig. 1, left). For right-handed subjects, the most common illusory percept is a single high tone in the right ear (RE), alternating with a single low tone in the left ear (LE) (Deutsch, 1974, 1983). Thus, both the *what* and *where* of the pitch perception are imperfect: Typically only one pitch is heard and the corresponding sound is localized for every second tone pair to the wrong side (*where* the sound is heard) (Deutsch, 1974; Deutsch and Roll, 1976; Deutsch, 2004).

The typical illusory percept is strongly associated with right-handedness, and many other percepts have been reported among left-handed subjects (Deutsch, 1974, 1983). According to Brancucci *et al.* (2009), the octave illusion can also be elicited by tones that differ almost but not exactly by an octave (major seventh, minor ninth, major ninth, and minor tenth); with small intervals (e.g., minor third), the illusory percepts are unlikely. The octave illusion has been elicited by tones lasting from 10 ms to 2 s (Zwicker, 1984), and it is perceived more often and more clearly with alternating 500-ms than 200-ms tones (Brancucci *et al.*, 2009). More-

over, it appears more consistently with sound sequences comprising 20 rather than 2 dichotic tone pairs (Deutsch, 1978). Brief gaps between the successive tones do not affect the illusory percept, but sound onset asynchrony of 3 s (either prolonged tones or gaps) significantly decreases the probability of the illusion (Deutsch, 1981). In addition to pure tones, the illusion can be elicited by complex sounds with a residue pitch of 400 and 800 Hz (McClurkin and Hall, 1981).

The behavioral results of the typical octave illusion have been explained by a two-channel model comprising separate “what” and “where” processing streams (Deutsch, 1975; Deutsch and Roll, 1976; Deutsch, 2004): The perceived pitch (*what*; Fig. 1, right) is determined by the dominant ear (generally RE for right-handed subjects) whereas the sound location (*where*; Fig. 1, right) follows the ear receiving the high tone. The model agrees with the established brain processing of different attributes of the auditory stimuli.

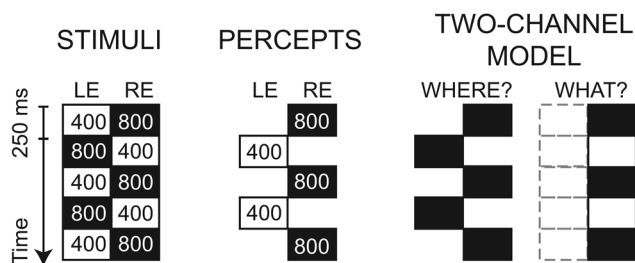

FIG. 1. Schematic presentation of the octave illusion. *Left panel*: Illusion-eliciting stimuli (used in behavioral screening). LE and RE refer to left-ear and right-ear inputs, respectively. Numbers 400 and 800 refer to tone frequency in Hz. *Middle panel*: Typical percepts of the stimuli. *Right panel*: Two-channel model according to Deutsch (2004): The perceived location (*where?*) follows the high tone (800 Hz) and the perceived pitch (*what?*) follows the RE input.

^{a)}Author to whom correspondence should be addressed. Electronic mail: satu.lamminmaki@aalto.fi

^{b)}Also at: Advanced Magnetic Imaging Centre, School of Science, Aalto University, P.O. Box 15100, FI-00076 AALTO, Espoo, Finland.

The *where* explanation is supported by the results of our previous magnetoencephalographic (MEG) study (Lamminmäki and Hari, 2000) where we recorded cortical onset responses to all four binaural pairs of 400- and 800-Hz tones, presented in isolation rather than in a continuous sequence. The auditory-cortex 100-ms response (N100m) was, in both hemispheres, stronger when the 800-Hz tone of the dichotic pair was presented to the contralateral rather than to the ipsilateral ear, thereby resembling responses to monaural stimuli (for a review, see Hari, 1990). The results therefore support the idea that the ear receiving the high (800-Hz) tone within the octave-illusion sound sequence determines the perceived location of the sound.

Here we studied more closely whether, and how, interaural interaction in the processing of a dichotic tone pair could contribute to the peculiar pitch perception during the octave illusion. Because a sound delivered to one ear reaches the auditory cortices of both hemispheres, the responses of auditory cortices are mixtures of responses to both ipsi- and contralateral sounds (usually with contralateral dominance). Although pitch processing during the illusion is assumed to rely differently on the LE and RE inputs (Deutsch and Roll, 1976; Deutsch, 1980), none of the previous octave-illusion studies has been able to separate brain signals according to the LE and RE inputs.

We have previously introduced a method to separate LE and RE inputs in cortical evoked responses. By “tagging” long continuous LE and RE sounds by amplitude modulation at different frequencies and then averaging the responses time-locked to the modulation signal, it is possible to selectively quantify the corresponding frequency-tagged steady-state fields (SSFs) to the input to each ear (Fujiki *et al.*, 2002; Kaneko *et al.*, 2003).

The auditory SSFs originate from the supratemporal auditory cortex (Mäkelä and Hari, 1987; Hari *et al.*, 1989; Gutschalk *et al.*, 1999). Typically, cortical SSFs to tones from one ear are weaker during binaural than monaural listening (Fujiki *et al.*, 2002; Kaneko *et al.*, 2003; Lamminmäki *et al.*, 2012). Until now, this binaural suppression (BS) has been studied only with same-pitch binaural tones. However, since the suppression reflects the interaction between the LE and RE inputs, it appears appropriate for studying interaural interaction during processing of dichotic tones as well.

Therefore, our aim was to investigate the role of binaural interaction in processing of tone frequencies that elicit the octave illusion.

II. METHODS

A. Subjects

From the 42 healthy adults who participated in psychoacoustic screening tests (see below), 19 subjects with the classical illusory percept (Deutsch, 1974) were selected for the MEG measurement (see Sec. III). None of the subjects had a history of hearing problems or neurological disorders. One subject was omitted from the analysis due to technical problems during MEG measurement and three subjects due to an insufficient signal-to-noise ratio of the SSFs for reliable source modeling (see Sec. II E). Thus, the analysis was based

on 15 subjects' data (9 females, 6 males; ages 19–47, mean 29.1 years; all right-handed with a mean score 94.6 and range 71–100 in the Edinburgh Handedness Inventory). We selected right-handers only because behavioral studies (Deutsch, 1974, 1983) have shown that most right-handers perceive the octave illusion in the “typical” way (a high tone in the RE alternating with a low tone in the LE) whereas the other percepts are more common among left-handers.

The study had a prior approval by the Ethics Committee of Helsinki Uusimaa Hospital District, and before participation all subjects signed a written consent form after a thorough explanation of the experiment.

B. Behavioral screening

The subjects' perceptions of the octave illusion were tested using tone sequences similar to those in Deutsch's (1974) original octave-illusion study (Fig. 1, left): a 400-Hz pure tone was presented to subject's one ear and an 800-Hz tone simultaneously to the other ear through earphones, and the locations of the tones were alternated once every 250 ms. The sounds followed each other without a gap, and the whole sequence lasted for 20 s. The subjects were presented with two sequences, one starting with the high tone in the RE and the other with the high tone in the LE. In addition, the corresponding two sequences with a 500-ms alternation rate were used, as the illusion is more likely with 500-ms than 200-ms tones (Brancucci *et al.*, 2009).

The subjects were asked to listen to the sound and to report afterwards verbally what they had heard. Subjects who found it difficult to describe their percept were asked to tell where and what kind of sound or sounds they had perceived.

C. Stimuli in MEG experiment

During the MEG experiment, we used 2-min continuous stimuli for assuring a sufficient signal-to-noise ratio for the SSFs—similarly as in the previous frequency-tagging studies (Fujiki *et al.*, 2002; Kaneko *et al.*, 2003; Lamminmäki *et al.*, 2012). All eight possible combinations of the 400-Hz and 800-Hz tones (illustrated in Fig. 2) were presented: (1) Four monaural stimuli, LE₄₀₀, RE₄₀₀, LE₈₀₀, and RE₈₀₀, where LE refers to left-ear input, RE to right-ear input, and the number to the tone frequency (either 400 or 800 Hz), (2) two binaural same-pitch stimuli, LE₄₀₀RE₄₀₀ and LE₈₀₀RE₈₀₀, where either the 400-Hz or the 800-Hz tone was presented to both ears, and (3) two dichotic stimuli, LE₄₀₀RE₈₀₀ and LE₈₀₀RE₄₀₀, which we call “octave-illusion stimuli.”

The parameters of the applied frequency tagging followed the previous studies (Kaneko *et al.*, 2003; Lamminmäki *et al.*, 2012) where the modulation frequencies were selected to produce minimum interference with the power-line frequency: The LE inputs were amplitude modulated at 41.1 Hz and the RE inputs at 39.1 Hz, all with 100% modulation depth (see the enlarged stimuli in Fig. 2). The modulation frequencies near 40 Hz maximize the SSFs (Galambos *et al.*, 1981; Stapells *et al.*, 1984; Hari *et al.*, 1989), and the selected modulation frequencies are close to each other but produce no overlapping harmonics. According to an earlier study (Fujiki

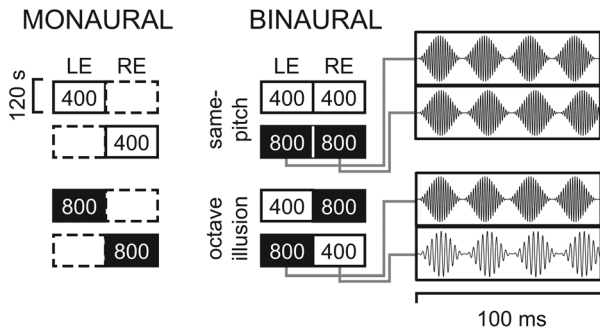

FIG. 2. Monaural (left), binaural same-pitch (middle top), and octave illusion stimuli (middle bottom) used in the MEG experiments and the two binaural stimuli enlarged (right). LE and RE refer to left-ear and right-ear inputs. LE tones were amplitude modulated at 41.1 Hz and RE tones at 39.1 Hz. The white boxes refer to 400-Hz tones, the black boxes to 800-Hz tones presented, and the boxes with dashed outlines to epochs of no stimulation.

et al., 2002), reversed modulation frequencies produce identical BSs.

The presentation order of the stimuli was randomized across the subjects, and for each subject the individual stimulus sequences were repeated once in a reverse order. The experiment lasted for about 45 min, out of which 32 min were used for presentation of the sounds and the rest for preparation and a pause between the two runs of the stimuli.

D. Experimental setup

During the MEG recording, the subject was sitting in a magnetically shielded room, with the head in the MEG helmet, and was instructed to pay no specific attention to the stimuli, keep the eyes open, and to avoid movements during the measurement.

The stimuli were presented through plastic tubes and earpieces. Since louder stimuli produce stronger SSFs (Ross *et al.*, 2000; Kaneko *et al.*, 2003; Picton *et al.*, 2003), and since sound loudness does not affect the magnitude of binaural interaction at 45–75 dB sensation level (Kaneko *et al.*, 2003), we set the sound intensity to the highest comfortable listening level (60–65 dB above the individual hearing threshold, for two subjects 55 dB), and balanced between the ears.

MEG signals were recorded with a whole-scalp 306-channel neuromagnetometer (Vectorview; Elekta Oy, Helsinki, Finland), which comprises 204 first-order planar gradiometers and 102 magnetometers arranged in a helmet-shaped array where each sensor unit houses two orthogonal gradiometers and one magnetometer. In the beginning and in the middle of the experiment, the position of the subject's head with respect to the MEG sensors was determined with the help of four head-position-indicator coils (attached to the forehead and both mastoids); the locations of the coils with respect to three anatomic landmarks (nasion and preauricular points) were determined using a three-dimensional digitizer.

The MEG signals were bandpass filtered to 0.03–200 Hz, sampled at 600 Hz, and averaged on-line time-locked to the modulation signal. The resulting steady-state responses were computed separately for the LE and RE inputs, yielding 12 averages (4 to monaural tones, 4 to binaural same-pitch tones, and 4 to binaural octave-illusion tones). The length of a single

analysis epoch (146 ms for LE inputs and 154 ms for RE inputs) corresponded to 6 cycles of the modulation frequency and the consecutive averaged time epochs overlapped by 4 cycles; thus 2000–2400 single epochs were averaged for each input (the difference resulting from the different modulation frequencies for LE and RE inputs) during the 120-s stimuli. Because filtering in a short window distorts the edges of the signal, only the two middle cycles of the epochs of six cycles were used for further analysis.

E. Data analysis

Averaged SSFs to the two presentations of each stimulus were first visually verified to be similar and then averaged (weighted by the number of the epochs in each run). In 2 subjects out of 15, SSFs to the 2 presentations of the same stimulus were analyzed separately. For one subject, only data from the first run were included because the signal-to-noise ratio was insufficient in the data from the second stimulation. SSFs were bandpass filtered to 32–48 Hz.

The magnetic field patterns elicited by the monaural stimuli were modeled with a well-established procedure (for a review, see Hämäläinen *et al.*, 1993) using two equivalent current dipoles (ECDs), one in each temporal lobe. Dipoles that explained over 85% of the signal variance in 28 planar gradiometers over each temporal lobe [black traces in Fig. 3(A)] were accepted for further analysis. For very weak and noisy responses, lower goodness-of-fit values were accepted if the dipoles (<3% of the all dipoles) were located in the brain just beneath the sensors with the strongest responses, and if the predicted and measured signals in those channels were similar on the basis of visual inspection. For five subjects, for whom the anatomical magnetic resonance images were available, the dipole locations were verified to agree with the location of the supratemporal auditory cortex.

The field patterns elicited by binaural stimuli (both same-pitch and octave-illusion sounds) were explained by the dipoles derived from the corresponding monaural conditions (e.g., dipoles fitted to LE₈₀₀ were also used to explain the field variance elicited by the LE input during LE₈₀₀RE₄₀₀, and dipoles fitted to RE₄₀₀ were used to explain the variance of the RE responses during LE₈₀₀RE₄₀₀). It is reasonable to suppose that the same input, presented to the same ear, activates about the same underlying neural population, at least at the accuracy of our measurements. Moreover, the usage of the same dipoles for same-pitch and octave illusion stimuli eliminated contamination from possible erroneous dipole fitting (especially depth). The procedure was verified in two subjects for whom dipoles were fitted separately to all stimuli, with results showing practically identical source locations and strengths.

We quantified BS separately for both hemispheres and both stimulus frequencies, e.g., for LE 400-Hz tone during the same-pitch stimuli according to the formula

$$\begin{aligned}
 &(\text{BS of LE input during LE}_{400}\text{RE}_{400}) \\
 &= (1 - Q[\text{LE}_{400} \text{ of LE}_{400}\text{RE}_{400}] / Q[\text{monaural LE}_{400}]) \\
 &\quad * 100\%,
 \end{aligned}$$

where Q refers to dipole moment in nAm. A positive (negative) BS value indicates that SSFs to the input of one ear, in the above example to the LE 400-Hz tone, are weaker (stronger) during binaural than monaural stimulation.

Our key question was whether the BS would differ between the same-pitch and octave-illusion stimuli. We therefore quantified the BS differences separately for both hemispheres as follows (here illustrated for LE input):

$$\begin{aligned} & (\text{BS of LE input during LE}_{400}\text{RE}_{800}) \\ & - (\text{BS of LE input during LE}_{400}\text{RE}_{400}), \end{aligned}$$

which equals to

$$\begin{aligned} & (Q[\text{LE}_{400} \text{ of LE}_{400}\text{RE}_{400}] \\ & - Q[\text{LE}_{400} \text{ of LE}_{400}\text{RE}_{800}]) / Q[\text{monaural LE}_{400}] * 100\%, \end{aligned}$$

where Q refers to the strength (dipole moment) of the equivalent dipole. BS differences were compared separately for LE and RE inputs, ipsi- and contralateral hemispheres, and 400-Hz and 800-Hz tones.

Statistically significant differences between stimulus conditions were assessed with two-tailed paired t -tests.

III. RESULTS

A. Behavioral study

With the alternating 500-ms tone pairs, all 15 subjects, selected on the basis of the behavioral pre-screening, had the

typical octave-illusion percept, that is a low tone in the LE alternating with a high tone in the RE (see Fig. 1, middle); the perceived locations remained the same also when the first tone-pair in the stimulus-sequence was reversed. Out of the 15 subjects, 13 had the same percept also with the 250-ms tones.

B. Steady-state responses

Figure 3(A) depicts the SSFs of one representative subject to monaural LE₈₀₀ tones, with the strongest responses in temporal-lobe areas of both hemispheres. The magnetic field patterns [Fig. 3(B)] were adequately explained by two current dipoles, located in the supratemporal auditory cortices of each hemisphere [Fig. 3(C)].

Figure 3(D) demonstrates the source strengths of SSFs evoked by the same left-ear 800-Hz tone, but during different conditions (i.e., the RE input was different). The dipoles were strongest to monaural LE₈₀₀ (solid lines) tones, and clearly suppressed during the binaural same-pitch stimuli LE₈₀₀RE₈₀₀ (dotted lines), and even more so during the octave-illusion stimuli LE₈₀₀RE₄₀₀ (dashed lines). In all these conditions, the sources to LE sounds were stronger in the right (contralateral) than the left (ipsilateral) hemisphere (RH, lower traces, vs LH, upper traces).

C. Source strengths

Figure 4 displays the mean \pm SEM (standard error of the mean) source strengths of SSFs in both ipsi- and contralateral hemispheres to the 400-Hz and 800-Hz tones during all applied stimuli.

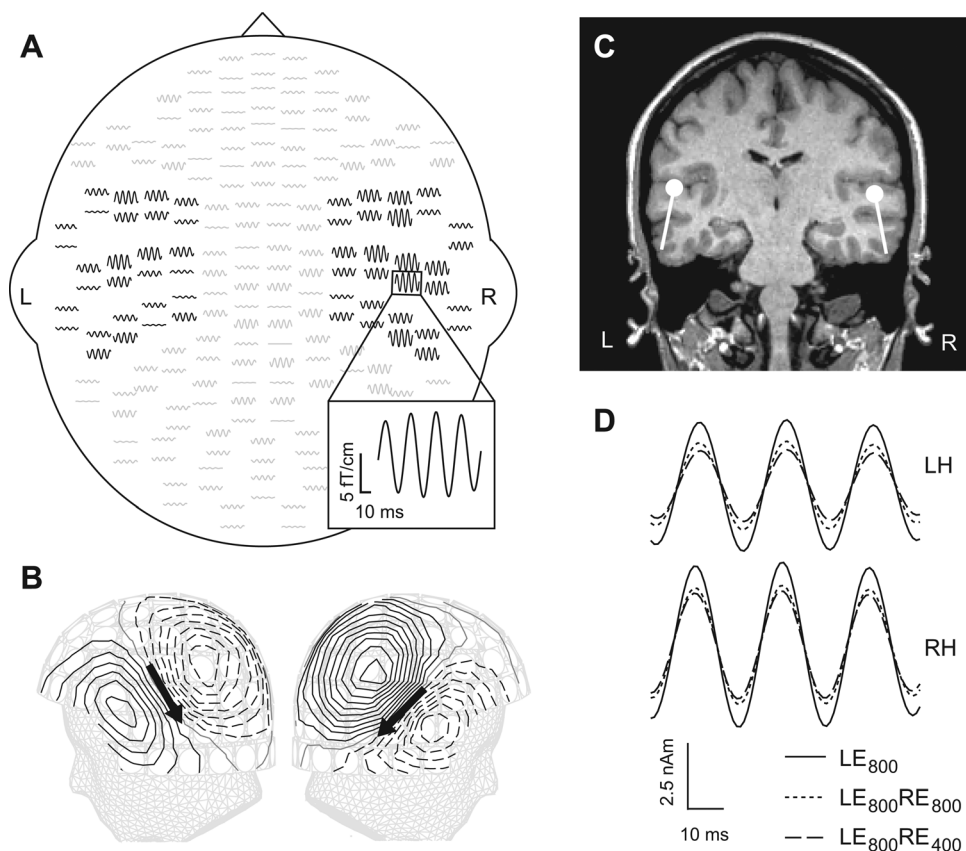

FIG. 3. Auditory SSFs in a representative subject. (A) Spatial distribution of SSFs to monaural left-ear 800-Hz tones (LE₈₀₀). Signals used for modeling the current-dipole sources in the temporal lobes are marked in black, and a single-channel response from the right hemisphere is enlarged. (B) Isocontour maps and the ECDs fitted separately to the left- and right-hemisphere responses to LE₈₀₀. The arrows show the directions and their midpoints the locations of the current dipoles. Isocontours (dashed lines indicate outward and the solid lines inward field) are separated by 2 fT. (C) Locations (spheres) and orientations (bars) of the dipoles on subject's own MRI image. (D) Source strengths (in nAm) to LE 800-Hz tones during LE₈₀₀ (solid line), LE₈₀₀RE₈₀₀ (dotted line), and LE₈₀₀RE₄₀₀ (dashed line) stimulation, both in the left and the right hemispheres (LH, RH).

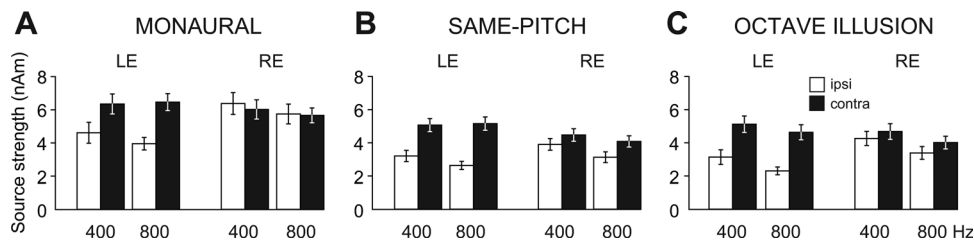

FIG. 4. Source strengths (mean \pm SEM in nAm) during monaural (A), same-pitch (B), and octave illusion stimuli (C), separately to the LE and RE inputs, 400-Hz and 800-Hz frequencies and ipsi/contralateral hemispheres (white and black bars, correspondingly).

During monaural stimulation [Fig. 4(A)], LE inputs elicited stronger contralateral than ipsilateral responses ($p < 0.008$ for both frequencies), whereas SSFs to the RE-stimuli showed no hemispheric differences. During binaural stimuli [same-pitch stimuli in Fig. 3(B) and octave-illusion stimuli in Fig. 3(C)], all inputs (LE and RE, 400 and 800 Hz) elicited stronger contralateral than ipsilateral responses ($p < 0.03$ for each comparison), in line with the results of Kaneko *et al.* (2003). During binaural stimuli, ipsilateral responses tended to be stronger to the 400-Hz than 800-Hz sounds (Table I) whereas the contralateral responses showed no significant differences.

D. Binaural suppression

Table II shows BSs for LE and RE inputs during binaural same-pitch stimuli. BS was statistically significant ($p < 0.002$) for both 400 and 800 Hz tones and in both hemispheres. BS was always stronger for ipsilateral than contralateral tones (ranges 24%–44% vs 17%–26%; $p < 0.03$ for each comparison).

Figure 5 illustrates the BS differences between the binaural same-pitch and octave illusion stimuli as ear dominance. For each ear, stronger BS means a weaker contribution to binaural responses. Therefore, a stronger BS for one ear results in a relatively stronger impact of the opposite ear's input. Figure 5 illustrates these ear dominances during octave illusion: Bars extending toward the right indicate a stronger right-ear dominance and bars extending toward the left indicate a stronger left-ear dominance compared with same-pitch stimuli.

The changes in ipsilateral suppressions (Fig. 5, top panels) indicated increased RE dominance both for 400-Hz ($p = 0.008$) and 800-Hz ($p = 0.004$) tones of the octave-illusion stimuli. In the contralateral suppressions (Fig. 5, bottom panels), the only statistically significant dominance change, compared with the same-pitch situation, was the increased RE dominance for the LE 800-Hz tones ($p < 0.02$).

TABLE I. Ipsilateral source strengths during binaural stimuli.

	(mean \pm SEM nAm)		<i>p</i> -value
	400 Hz	800 Hz	
LE			
same-pitch	3.2 \pm 0.3	2.6 \pm 0.2	0.04
octave-illusion	3.1 \pm 0.4	2.3 \pm 0.2	0.04
RE			
same-pitch	3.9 \pm 0.4	3.1 \pm 0.3	0.01
octave-illusion	4.2 \pm 0.4	3.4 \pm 0.4	0.07

IV. DISCUSSION

A. Binaural interaction of dichotic tones

By means of frequency-tagged steady-state MEG responses, we were able to demonstrate that the strengths of SSFs to tones presented to one ear vary depending on whether a similar tone or a tone separated by an octave is presented simultaneously to the other ear. We attribute this difference to modified binaural interaction.

During both dichotic stimuli, ipsilateral SSFs to the LE inputs were weaker, and to the RE inputs stronger than during same-pitch stimuli. Furthermore, only to the LE₈₀₀RE₄₀₀ stimulus—which during the octave illusion was perceived as a LE 400-Hz tone—also contralateral responses to the LE tone were weaker than during the same-pitch stimuli. All these differences indicate an increased RE dominance during the dichotic stimuli.

Our MEG results elucidate the vaguely known binaural interaction between dichotic tones and thereby illuminate the neuronal basis of the peculiar pitch percepts during the octave illusion. Specifically, the results support the behavioral two-channel model of the octave illusion (Deutsch, 1975; Deutsch and Roll, 1976; Deutsch, 2004), according to which (in right-handed subjects) the LE input remains unperceived whereas the RE input is perceived during the illusory percept. In addition, the observed RE dominance of the contralateral SSFs to the LE 800-Hz input may relate to the perception of the RE 400-Hz tone incorrectly in the LE. During the other octave-illusion stimulus, LE₄₀₀RE₈₀₀, no changes were observed in the ear dominance of the contralateral SSFs, and during the corresponding phase of the actual illusion sequence, the perceived location of the high tone corresponded to the physical stimulus. It is thus likely that the modified binaural interaction between dichotic tones contributes to the illusion.

B. Neurophysiological basis of the octave illusion

The experimental results of our current and previous MEG study form the basis for a tentative neurophysiological

TABLE II. BS during same-pitch stimuli.

	BS (mean \pm SEM %)	
	Ipsilateral	Contralateral
LE		
400 Hz	23.9 \pm 4.8	16.8 \pm 4.4
800 Hz	32.0 \pm 4.3	18.9 \pm 3.7
RE		
400 Hz	37.0 \pm 2.6	24.1 \pm 3.3
800 Hz	44.2 \pm 4.2	25.5 \pm 2.6

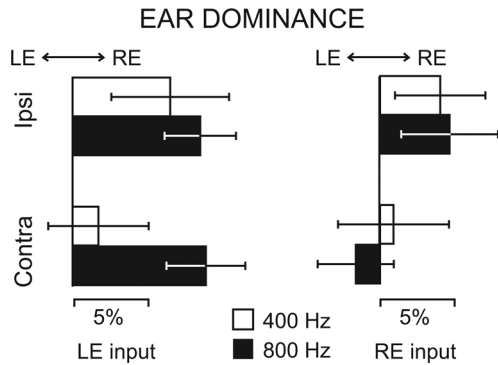

FIG. 5. Ear dominances, quantified as differences of BS between the same-pitch and octave-illusion conditions (mean \pm SEM %). Bar directions indicate the dominant ear. RE dominance means *stronger* suppression of LE inputs and *weaker* suppression of RE inputs during the octave-illusion than during the same-pitch stimuli.

counterpart for the behavioral two-channel model of the octave illusion (Deutsch, 1975; Deutsch and Roll, 1976; Deutsch, 2004). The two-channel model assumes that the perceived location of the sounds during the illusion (*where?*) follows the ear that is currently receiving the higher-frequency tone, and the perceived pitch sequence (*what?*) matches the RE input.

The *where*-part of our proposed neurophysiological model (Fig. 6, left) illustrates the neural mechanisms underlying the perceived sound location, as revealed by an earlier MEG study (Lamminmäki and Hari, 2000): In the auditory cortex of each hemisphere, the transient N100m response was stronger when the high-frequency (800 Hz) input was

NEUROPHYSIOLOGICAL TWO-CHANNEL MODEL

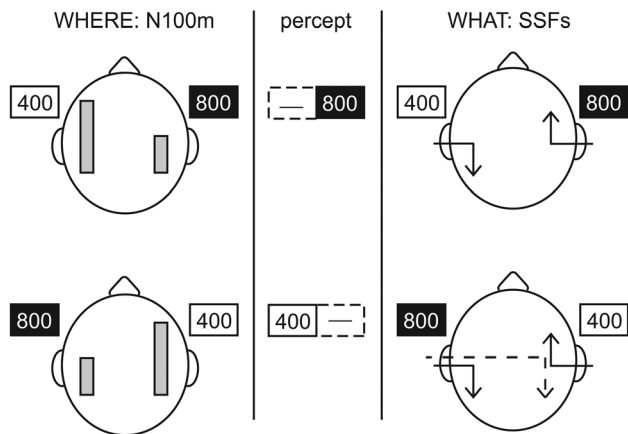

FIG. 6. Suggested neurophysiological two-channel model of the octave illusion. *Left panel*: *Where* processing, based on the results of our previous study (Lamminmäki and Hari, 2000). The vertical bars indicate the strengths of the N100m responses (stronger in the hemisphere contralateral to the 800-Hz tone). *Middle panel*: The perceived pitch and location (ear) of the monaural sound during the octave illusion. *Right panel*: *What* processing, based on the results of the present study. Solid arrows indicate differences in ipsilateral steady-state responses between the octave-illusion and the same-pitch stimuli, a dashed arrow depicts contralateral responses. During both octave-illusion stimuli, LE₄₀₀RE₈₀₀ (top) and LE₈₀₀RE₄₀₀ (bottom), ipsilateral responses to the LE inputs (unperceived during the illusion) were weaker, and to the RE inputs (perceived during the illusion) stronger than during the corresponding same-pitch stimuli. During LE₈₀₀RE₄₀₀ (bottom), contralateral responses to the LE input were weaker as well.

presented to the contralateral ear and the low-frequency (400 Hz) tone to the ipsilateral ear than vice versa. N100m is a response to sound changes (both onsets and offsets) and can be elicited by almost any type of abrupt sounds (for a review, see Hari, 1990). Typically, N100m responses show a clear contralateral dominance during monaural stimulation (Hari and Mäkelä, 1988; Mäkelä *et al.*, 1993). In addition, N100m is stronger to contralaterally- than ipsilaterally-leading binaural clicks in trains with interaural time differences serving as sound location cues (McEvoy *et al.*, 1994). Therefore, N100m likely carries information about sound location, being informative about the *where*-part of our neurophysiological model.

The current results contribute to the explanation of the *what*-part of the illusion (Fig. 6, right): During long dichotic tones of the same frequencies as in the octave-illusion sequence, a clear RE dominance was evident in all ipsilateral SSFs. For ipsilateral SSFs, the observed RE dominance implies relatively increased RH responses and/or relatively decreased LH responses. The dominant role of RH in pitch and melody processing is well established (for a review, see, e.g., Zatorre, 2001). For example, RH lesions impair pitch perception (for a review, see Stewart *et al.*, 2006), and the auditory cortex is sensitive to much smaller pitch differences in the right than the left hemisphere (Hyde *et al.*, 2008).

In addition, during the most paradoxical stimulus, LE₈₀₀RE₄₀₀, perceived incorrectly as monaural LE₄₀₀ during the octave illusion, even the contralateral SSFs to LE tones were diminished. We suggest that this additional RE-dominance during LE₈₀₀RE₄₀₀ supports the perception of the RE tone in the LE.

To conclude, our current and previous results provide together a neurophysiological explanation for the perceived pitches and locations in the octave illusion, in concordance with the behavioral two-channel model.

ACKNOWLEDGMENTS

This study was supported financially by the Academy of Finland (National Centres of Excellence Programme 2006–2011, Grant Nos. 129678, 218072, and 131483), ERC Advanced Grant No. 232946, the Sigrid Jusélius Foundation, and the Signe and Ane Gyllenberg Foundation, and the aivoAALTO research project of the Aalto University. We thank Mia Illman for help in MEG measurements.

Brancucci, A., Padulo, C., and Tommasi, L. (2009). "Octave illusion or Deutsch's illusion?," *Psychol. Res.* **73**, 303–307.
 Deutsch, D. (1974). "An auditory illusion," *Nature*. **251**, 307–309.
 Deutsch, D. (1975). "Musical illusions," *Sci. Am.* **233**, 92–98, 103–104.
 Deutsch, D. (1978). "Lateralization by frequency for repeating sequences of dichotic 400- and 800-Hz tones," *J. Acoust. Soc. Am.* **63**, 184–186.
 Deutsch, D. (1980). "Ear dominance and sequential interactions," *J. Acoust. Soc. Am.* **67**, 220–228.
 Deutsch, D. (1981) "The octave illusion and auditory perceptual integration," in *Hearing Research and Theory*, edited by J. V. Tobias and E. D. Schubert (Academic Press, New York), pp. 99–142.
 Deutsch, D. (1983). "The octave illusion in relation to handedness and familial handedness background," *Neuropsychologia* **21**, 289–293.
 Deutsch, D. (2004). "The octave illusion revisited again," *J. Exp. Psychol. Hum. Percept. Perform.* **30**, 355–364.
 Deutsch, D., and Roll, P. L. (1976). "Separate 'what' and 'where' decision mechanisms in processing a dichotic tonal sequence," *J. Exp. Psychol. Hum. Percept. Perform.* **2**, 23–29.

- Fujiki, N., Jousmäki, V., and Hari, R. (2002). "Neuromagnetic responses to frequency-tagged sounds: A new method to follow inputs from each ear to the human auditory cortex during binaural hearing," *J. Neurosci.* **22**, RC205.
- Galambos, R., Makeig, S., and Talmachoff, P. J. (1981). "A 40-Hz auditory potential recorded from the human scalp," *Proc. Natl. Acad. Sci. U.S.A.* **78**, 2643–2647.
- Gutschalk, A., Mase, R., Roth, R., Ille, N., Rupp, A., Hahnel, S., Picton, T. W., and Scherg, M. (1999). "Deconvolution of 40 Hz steady-state fields reveals two overlapping source activities of the human auditory cortex," *Clin. Neurophysiol.* **110**, 856–868.
- Hämäläinen, M., Hari, R., Ilmoniemi, R. J., Knuutila, J., and Lounasmaa, O. V. (1993). "Magnetoencephalography—theory, instrumentation, and applications to noninvasive studies of the working human brain," *Rev. Mod. Phys.* **65**, 413–497.
- Hari, R. (1990). "The neuromagnetic method in the study of the human auditory cortex," in *Auditory Evoked Magnetic Fields and Electric Potentials. Advances in Audiology*, edited by F. Grandori, M. Hoke, and G. Romani (S. Karger, Basel), pp. 222–282.
- Hari, R., Hämäläinen, M., and Joutsiniemi, S. L. (1989). "Neuromagnetic steady-state responses to auditory stimuli," *J. Acoust. Soc. Am.* **86**, 1033–1039.
- Hari, R., and Mäkelä, J. P. (1988). "Modification of neuromagnetic responses of the human auditory cortex by masking sounds," *Exp. Brain Res.* **71**, 87–92.
- Hyde, K. L., Peretz, I., and Zatorre, R. J. (2008). "Evidence for the role of the right auditory cortex in fine pitch resolution," *Neuropsychologia* **46**, 632–639.
- Kaneko, K., Fujiki, N., and Hari, R. (2003). "Binaural interaction in the human auditory cortex revealed by neuromagnetic frequency tagging: no effect of stimulus intensity," *Hear Res.* **183**, 1–6.
- Lamminmäki, S., and Hari, R. (2000). "Auditory cortex activation associated with octave illusion," *NeuroReport* **11**, 1469–1472.
- Lamminmäki, S., Massinen, S., Nopola-Hemmi, J., Kere, J., and Hari, R. (2012). "Human *ROBO1* regulates interaural interaction in auditory pathways," *J. Neurosci.* **32**, 966–971.
- Mäkelä, J. P., Ahonen, A., Hämäläinen, M., Hari, R., Ilmoniemi, R. J., Kajola, M., Knuutila, J., Lounasmaa, O. V., McEvoy, L., Salmelin, R., Salonen, O., Sams, M., Simola, J., Tesche, C., and Vasama, J.-P. (1993). "Functional differences between auditory cortices of the two hemispheres revealed by whole-head neuromagnetic recordings," *Hum. Brain Mapp* **1**, 48–56.
- Mäkelä, J. P., and Hari, R. (1987). "Evidence for cortical origin of the 40 Hz auditory evoked response in man," *Electroencephalogr. Clin. Neurophysiol.* **66**, 539–546.
- McClurkin, R. H., and Hall, J. W., III (1981). "Pitch and timbre in a two-tone dichotic auditory illusion," *J. Acoust. Soc. Am.* **69**, 592–594.
- McEvoy, L., Mäkelä, J. P., Hämäläinen, M., and Hari, R. (1994). "Effect of interaural time differences on middle-latency and late auditory evoked magnetic fields," *Hear Res.* **78**, 249–257.
- Picton, T. W., John, M. S., Dimitrijevic, A., and Purcell, D. (2003). "Human auditory steady-state responses," *Int. J. Audiol.* **42**, 177–219.
- Ross, B., Borgmann, C., Draganova, R., Roberts, L. E., and Pantev, C. (2000). "A high-precision magnetoencephalographic study of human auditory steady-state responses to amplitude-modulated tones," *J. Acoust. Soc. Am.* **108**, 679–691.
- Stapells, D. R., Linden, D., Suffield, J. B., Hamel, G., and Picton, T. W. (1984). "Human auditory steady state potentials," *Ear Hear.* **5**, 105–113.
- Stewart, L., von Kriegstein, K., Warren, J. D., and Griffiths, T. D. (2006). "Music and the brain: Disorders of musical listening," *Brain* **129**, 2533–2553.
- Zatorre, R. J. (2001). "Neural specializations for tonal processing," *Ann. N.Y. Acad. Sci.* **930**, 193–210.
- Zwicker, T. (1984). "Experimente zur dichotischen Oktav-Tauschung (Experiments on dichotic octave illusion)," *Acustica* **55**, 128–136.