

Publication V

M. Ojanen, K. Anhalt, J. Hartmann, S. Schiller, T. Weckström, P. Kärhä, M. Heinonen, and E. Ikonen. 2010. Comparison of the radiation temperature scales between MIKES and PTB. *Measurement*, volume 43, number 2, pages 183-189.

© 2009 Elsevier Science

Reprinted with permission from Elsevier.



ELSEVIER

Contents lists available at ScienceDirect

Measurement

journal homepage: www.elsevier.com/locate/measurement

Comparison of the radiation temperature scales between MIKES and PTB

M. Ojanen^{a,*}, K. Anhalt^b, J. Hartmann^b, S. Schiller^b, T. Weckström^c, P. Kärhä^a,
M. Heinonen^c, E. Ikonen^{a,c}

^a Helsinki University of Technology (TKK), Metrology Research Institute, P.O.B. 3000, FI-02015 TKK, Finland

^b Physikalisch-Technische Bundesanstalt (PTB), Abbestr. 2-12, 10587 Berlin, Germany

^c Centre for Metrology and Accreditation (MIKES), P.O.B. 9, FI-02151 Espoo, Finland

ARTICLE INFO

Article history:

Received 9 February 2009

Received in revised form 14 July 2009

Accepted 19 September 2009

Available online 24 September 2009

Keywords:

Filter radiometer

Intercomparison

Linear radiation thermometer

Radiation temperature scale

ABSTRACT

The radiation temperature scales of PTB and MIKES were compared in the range of 1570–2770 K using four filter radiometers of MIKES, one filter radiometer of PTB, and linear radiation thermometers of both MIKES and PTB. The agreement was partial: two filter radiometers and the linear radiation thermometer of MIKES agreed well with the equipment of PTB, while two filter radiometers deviated from the other equipment. To get a deeper understanding of the reasons of the deviation, the results were studied in terms of both temperature and radiance. The deviation was found constant in terms of radiance. A correction factor was calculated for the radiance level with help of a temperature fixed-point calibration. The use of the correction factor improved the results.

© 2009 Elsevier Ltd. All rights reserved.

1. Introduction

Radiation thermometry is based on measurements of spectral radiance. Temperature measurements are thus strongly linked to precision spectroradiometry. The International Temperature Scale of 1990 (ITS-90) is based on the Planck's radiation law above the silver freezing point, 1234.93 K. According to ITS-90, the temperature is measured relative to a temperature fixed-point using a linear radiation thermometer [1]. The thermodynamic temperature of a blackbody can also be measured directly using absolutely (radiometrically) calibrated filter radiometers. Intercomparisons are commonly carried out to verify the accuracies of the temperature and the radiance scales of the national metrology institutes [2–5]. Filter radiometers and linear radiation thermometers described and used in this paper have previously been compared, e.g., in [6–9].

An intercomparison of the temperature scales between the Centre for Metrology and Accreditation (MIKES, Finland) and the Physikalisch-Technische Bundesanstalt

(PTB, Germany) was arranged in March 2007, and it was carried out as a part of an implementing the Metrology European Research Area (iMERA) project using the Primary Temperature Radiator (PriTeRa) special facility of PTB [10,11]. One of the project goals was to enhance the international collaboration in the field of metrology in Europe, and to open the national measurement and calibration facilities for the metrologists from other National Metrology Institutes. The measurements were carried out at the Berlin site of PTB. The measurement artifact was a high-temperature blackbody HTBB3200pg made of pyrolytic graphite rings [12]. Temperatures between 1570 K and 2770 K were measured. The measurement equipment consisted of four filter radiometers of MIKES with central wavelengths from 600 to 900 nm, one filter radiometer from PTB with central wavelength of 800 nm, and LP3 linear radiation thermometers from both PTB and MIKES. With help of this comparison, the temperature measurement equipment of MIKES was able to be tested at higher temperatures, as MIKES only has blackbody sources up to 1800 K.

In this paper, we first describe the measurement equipment, the setup and the measurement scheme. Then we

* Corresponding author. Tel.: +358 9 451 2336; fax: +358 9 451 2222.
E-mail address: maiya.ojanen@tkk.fi (M. Ojanen).

present the results of the comparison. Finally, the results are analyzed in terms of both temperature and spectral radiance.

2. Materials and methods

2.1. Measurement equipment

2.1.1. Filter radiometers

To determine the radiation temperature of a blackbody, one needs to measure its radiance. The radiance of a blackbody with a known radiating aperture can be measured with an absolutely calibrated irradiance mode filter radiometer equipped with a known limiting aperture set at a known distance from the blackbody [11]. In such a measurement, the photocurrent i of the filter radiometer depends on the temperature T as

$$i = \frac{A_{BB} \left(1 + \frac{r_{BB}^2 r_{FR}^2}{D^4}\right)}{D^2} \varepsilon \int S(\lambda) L(\lambda, T) d\lambda, \quad (1)$$

where λ is the wavelength and $S(\lambda)$ is the spectral irradiance responsivity of the filter radiometer defined by the filter transmittance, the detector responsivity and the aperture area. Function $L(\lambda, T)$ is the spectral radiance of the blackbody output given by the Planck's radiation law, A_{BB} is the aperture area of the blackbody, r_{BB} is the radius of the blackbody aperture, r_{FR} is the radius of the filter radiometer aperture, and ε is the emissivity of the blackbody. The geometric factor D is defined as $D^2 = d^2 + r_{BB}^2 + r_{FR}^2$, where d is the distance between the filter radiometer aperture and the blackbody aperture.

All of the MIKES filter radiometers consist of a trap detector made of three silicon photodiodes. The construction of the MIKES filter radiometers is described in [13]. The housing of filter radiometer FR1 has an interchangeable filter, and its components are characterized separately. The FR2-type housing is similar to FR1, except that the filter is permanently installed. The filters used in FR1 are narrow-band-pass interference filters at nominal center wavelengths of 800 and 900 nm, and a broad-band $V(\lambda)$ -filter. The FR2 has a narrow-band 800-nm interference filter installed. In both filter radiometer constructions, the interreflections between the trap detector and the filter are around 0.01–0.02%. The temperatures of the filter radiometers are electrically controlled.

The calibration procedure for the FR1 radiometers is described in [14] and for the FR2 in [15]. The FR1-type filter radiometers were characterized component by component. The responsivity and the reflectance of the trap detector were measured and modeled to cover the ultraviolet, the visible and the near infrared wavelength regions in autumn 2006. The transmittances of the filters of MIKES-FR1-600, MIKES-FR1-800 and MIKES-FR1-900 were measured before and after the intercomparison in spring 2007. The aperture area was measured in spring 2007. The spectral irradiance responsivity of FR2 was measured for the combination of the detector, the filter and the aperture, using a laser scanning method [15] in spring 2006.

The detailed uncertainty analysis for the MIKES filter radiometers is presented in [7]. The most dominant uncertainty components associated with the MIKES filter radiometers are the measurement wavelength, the transmittances of the filters and the responsivity model of the trap detectors. The combined expanded uncertainties associated with temperature measurements are presented in Table 1.

The filter radiometer of the PTB has a pass-band of 20 nm with central wavelength of 800 nm. The diameter of the precision aperture is 5 mm. The filter radiometer is water-cooled, which enables high stability. The calibration procedures and the uncertainty determination of this filter radiometer are described in [8,11,16] and its ultimate stability is demonstrated in [9]. The calibration is carried out using a spectral comparator facility. The stray light contribution is reduced by using a prism monochromator as pre-disperser for the grating monochromator. A Glan-Thompson polarization prism is inserted behind the grating monochromator to obtain the spectral responsivity for unpolarized light. The measurement results are corrected for diffraction effects [17].

2.1.2. Linear radiation thermometers

In this study, both PTB and MIKES used linear radiation thermometers of type LP3 from KE Technologie GmbH [18].

For the LP3-MIKES, the measured temperature is calculated from the measured photocurrent $I_{ph,\lambda}$ as

$$T = \left[\frac{1}{T_{cal}} - \frac{\lambda_{eff}}{c_2} \ln \frac{I_{ph,\lambda}}{\zeta \cdot I_{cal,\lambda}} \right]^{-1}, \quad (2)$$

where $c_2 = 1.4388 \times 10^{-2}$ Km is the second radiation constant defined by the Commission Internationale de l'Eclair-

Table 1

Expanded uncertainties ($k = 2$) in temperature of the participating instruments at different temperatures. Values are given in Kelvin.

T (K)	ITS-90 via C514	MIKES-FR1-600	MIKES-FR1-800	MIKES-FR1-900	MIKES-FR2-800	PTB-FR-800	PTB-LP3	MIKES-LP3
1570	0.3	0.5	0.5	0.5	0.3	0.2	0.8	0.8
1670	0.3	0.5	0.6	0.6	0.3	0.2	0.8	0.8
1770	0.3	0.6	0.6	0.7	0.4	0.2	0.8	0.9
1970	0.4	0.6	0.8	0.8	0.4	0.3	0.9	1.4
2170	0.5	0.7	0.9	1.0	0.5	0.3	1.1	2.0
2270	0.6	0.8	1.0	1.1	0.6	0.3	1.1	2.4
2370	0.6	0.8	1.1	1.2	0.6	0.4	1.2	2.7
2570	0.7	0.9	1.2	1.4	0.8	0.4	1.3	3.5
2770	0.8	1.1	1.4	1.7	0.9	0.5	1.5	4.4

rage (CIE), λ_{eff} is the effective wavelength defined by the filter, the detector and the fore optics, T_{cal} is the reference temperature of the fixed-point cell calibration, $I_{\text{cal},\lambda}$ is the reference current and $\zeta = \kappa\epsilon\tau\rho$ combines the attenuation factor κ of the filter, the emissivity ϵ of the target, the transmittance of the filter τ , and the reflectance of the optical components ρ .

The values T_{cal} , $I_{\text{cal},\lambda}$ and κ are determined by calibration. The effective wavelength λ_{eff} is defined by measuring the silver and the copper fixed-point temperatures, T_1 and T_2 , and recording the corresponding radiation thermometer signals $S(T_1)$ and $S(T_2)$. Applying Wien's approximation gives the effective wavelength as

$$\lambda_{\text{eff}} = \frac{c_2 \left(\frac{1}{T_1} - \frac{1}{T_2} \right)}{\ln \left(\frac{S(T_2)}{S(T_1)} \right)}. \quad (3)$$

The resulting effective wavelength is 652.73 nm.

The characterization of the LP3-PTB is made by determining the linear relationship between the output signal and the spectral radiance of the measurement source at the range of 1200–3000 K in temperature steps of 200 K. The resulting photocurrent I_{ph} is fitted to the Sakuma–Hattori equation [19], and the temperature calculation is carried out as

$$T_R = -\frac{c_2}{a \ln(I_{\text{ph},\lambda}/c)} - \frac{b}{a}, \quad (4)$$

where T_R is the radiation temperature, and a , b and c are constants defined by the calibration. The calibration is performed against a high-temperature blackbody BB3200pg, which is traceable to gold fixed-point [5].

The expanded uncertainties associated with the linear radiation thermometers are presented in Table 1. The uncertainty associated with linear radiation thermometer measurements arises from the uncertainty of the reference temperatures, repeatability of the measurement signal and the non-linearity of the radiation thermometer.

2.1.3. High-temperature blackbody

The thermal radiation source used is a well-characterized high-temperature blackbody (HTBB) of type BB3200pg. The cavity is formed by pyrolytic graphite rings. The housing of the HTBB is water-cooled. The temperature of the HTBB is continuously monitored with a radiation thermometer from the back side. The length of the cavity is approximately 250 mm and the diameter is 37 mm. The emissivity is 0.999 ± 0.0005 . The construction and the operation of the BB3200pg are described in more detail in [11,20]. A water-cooled precision aperture is mounted in front of the blackbody. This allows the radiance of the cavity to be measured with irradiance mode filter radiometers. The diameter of the aperture is (20.012 ± 0.001) mm. The uncertainty associated with the HTBB consists of the stability of the temperature, the size-of-source effect and the uncertainty of the emissivity. The expanded uncertainty associated with the reference temperature is presented in Table 1.

2.2. Measurement setup and procedure

The setup used in the measurements is presented in Fig. 1. The measurement devices were installed on a translation stage to allow fast interchange of the equipment. The devices were aligned using a laser beam and a mirror. The distance between the blackbody and the detector was set to about 1 m for the filter radiometers, and it was measured with a calibrated rod. The distance between the blackbody and the front plates of the linear radiation thermometers was 700 mm. The distance was measured to a plate which was 15.2 mm in front of the defining aperture of the blackbody. The measured photocurrents were converted into voltage signals using a current-to-voltage converter and read with a calibrated high-accuracy digital multimeter.

One measurement round consisted of 10 signal and 10 dark current measurements using all filter radiometers and the linear radiation thermometers. A tungsten strip lamp C514 was used to measure the HTBB temperature according to the ITS-90. The measurement round was repeated five times for each filter radiometer at each temperature. Two to four temperatures were measured per day at 200 K steps.

3. Results

The radiation temperature measurement results for the filter radiometers are shown in Fig. 2. In the early stage of the analysis it became apparent that some of the MIKES filter radiometers deviated from the others, and it was decided that the filter radiometers of MIKES are compared to the filter radiometer of PTB. This approach allowed direct comparison of the measured thermodynamic temperatures. The filter radiometers MIKES-FR1-600 and MIKES-FR2-800 show agreement with PTB-FR-800 over the whole temperature range. The results are also consistent with each other. The typical deviation from PTB for MIKES-FR1-600 and MIKES-FR2-800 is around 0.4 K for the lower temperatures and around 1.2 K for the higher temperatures. The deviations of MIKES-FR1-800 and MIKES-FR1-900 from the reference values are larger, higher than the expanded uncertainties. The typical deviation for MIKES-FR1-800 and MIKES-FR1-900 is around 1.0 K for the lower temperatures and around 3 K for the higher temperatures.

The results of the linear radiation thermometers are compared to PTB-FR-800 in Fig. 3. The results are in good agreement. The difference between the linear radiation thermometers and PTB-FR-800 is between 0.05 K and 1.0 K for MIKES-LP3, and between 0.08 K and 0.46 K for PTB-LP3, depending on the temperature. Using PTB-FR-800 as the reference allowed the comparison of direct thermodynamic temperature and ITS-90 based scale realization.

To get an understanding on the level of agreement in radiometric measurements, the results of the MIKES filter radiometers were also analyzed in terms of spectral radiance. The spectral radiance values of the HTBB at the effective wavelengths, calculated using Planck's radiation law, were used as the reference values with which the mea-

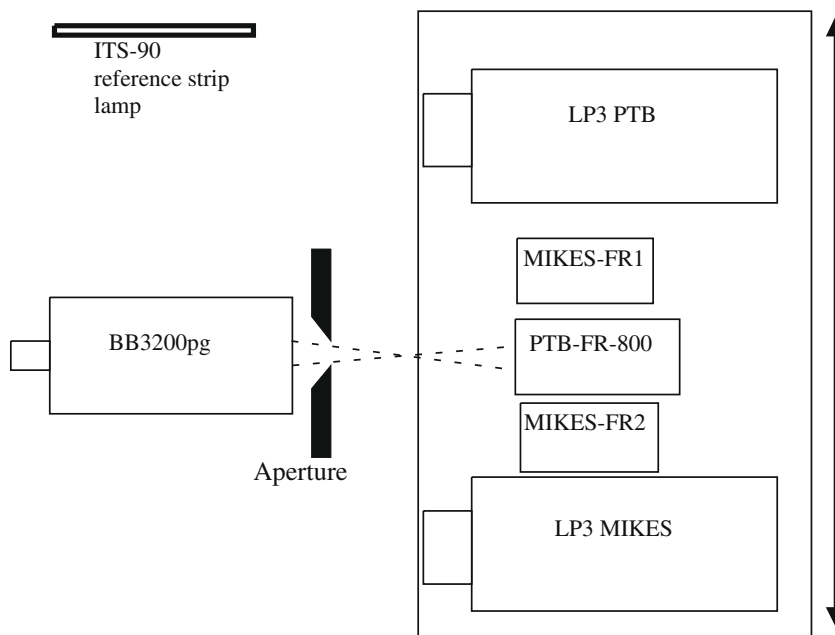

Fig. 1. Measurement setup. The filter radiometers and the linear radiation thermometers are installed on a translator stage. The defining aperture is placed in front of the HTBB (BB3200pg).

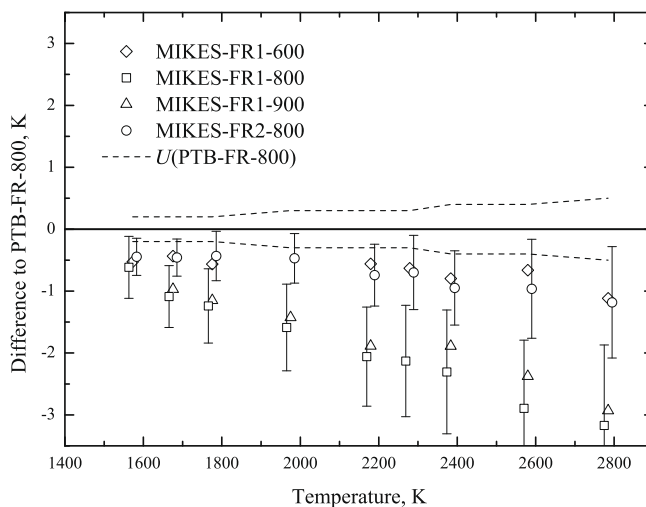

Fig. 2. Difference between the temperature measurement results of MIKES filter radiometers and PTB-FR-800. Typical expanded uncertainties are given for MIKES-FR1-800 and MIKES-FR2-800. The dashed lines represent the expanded uncertainty of PTB-FR-800.

sured spectral radiances were compared. The results are presented in Fig. 4. As the figure shows, the differences in radiance are quite constant. The relative average deviations in radiance are -0.23% , -0.66% , -0.51% and -0.19% for the filter radiometers MIKES-FR1-600, MIKES-FR1-800, MIKES-FR1-900 and MIKES-FR2-800 at their respective wavelengths.

A correction factor for the radiance level of the MIKES filter radiometers was calculated with help of an Ag fixed-point calibration carried out at MIKES. First, the expected radiance was calculated using the Planck's law at the silver freezing point temperature. The measured radiance in the Ag point calibration was calculated from the

photocurrent using Eq. (1). Then the measured and expected radiances, $L(\lambda, T_M)$ and $L(\lambda, T_{90})$, were compared to calculate the correction

$$C = \frac{L(\lambda, T_{90}) - L(\lambda, T_M)}{L(\lambda, T_M)}. \quad (5)$$

The differences of the measured and the radiance corrected temperatures to the PTB-FR-800 at each measurement point are presented in Fig. 5. The deviations from the PTB-FR-800 reduced for the filter radiometers MIKES-FR1-600, MIKES-FR1-900 and MIKES-FR2-800. The radiance correction did not improve the results of the MIKES-FR1-800, and it was thus left out from Fig. 5.

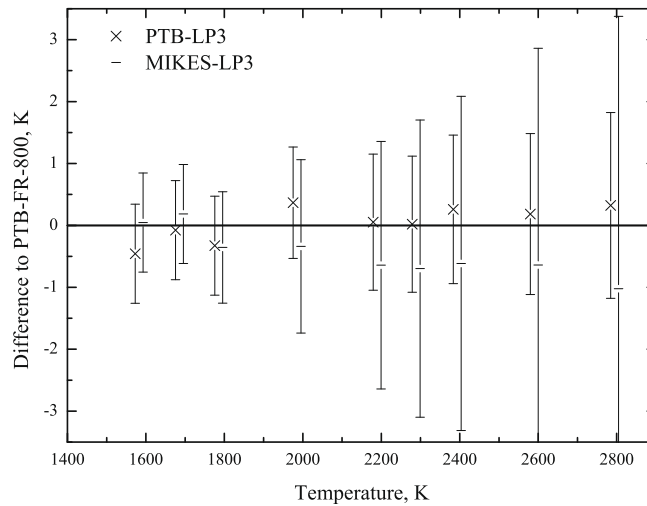

Fig. 3. Difference between the temperature measurement results of the linear radiation thermometers and PTB-FR-800.

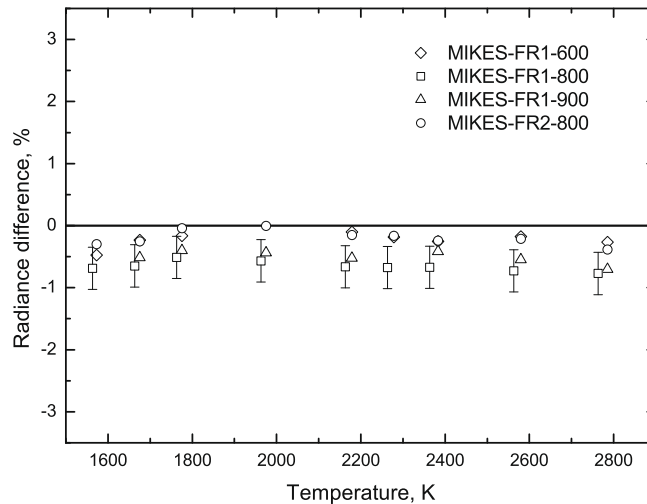

Fig. 4. The deviations of the MIKES filter radiometers analyzed in terms of radiance, given as deviations from the HTBB radiance. Typical expanded uncertainties ($k = 2$) are given for MIKES-FR1-800.

Possible causes for the deviations of MIKES-FR1-800 and MIKES-FR1-900 could be instability of the filter radiometers, differences in the measurement geometries for the filter transmittance and the radiation temperature measurement, spatial non-uniformities of the filters, and diffuse transmittance components in the filters. The stability of the filters was studied by measuring the filters before and after the comparison. The measurements showed no significant changes. The stability of the detector was also studied in autumn 2007, and it was found to be stable.

The measurements with the $V(\lambda)$ -filter and the FR2 type housing were successful, which indicates that the problems are related with the interchangeable interference filters. The f -number in the temperature measurements is 1/60. Two different setups have been used for transmittance measurements. The reference spectrometer

has an f -number close to infinity [21]. For the other commercial device, the f -number is 1/10. The results obtained with the two setups have been compared, and they agree within uncertainties. Another difference between the geometries is the distance between the filter and the detector. In the transmittance measurements with the commercial device, the filter is placed at a distance of 20–30 cm from the detector. When attached to the filter radiometer, the distance between the filter and the detector is approximately 5 cm. The shapes and sizes of the beams in the setups vary, which also might explain some of the deviations.

When the interference filters age, diffuse transmittance components may appear. The diffuse transmittance components may produce differences in the observed signal levels at different measurement distances.

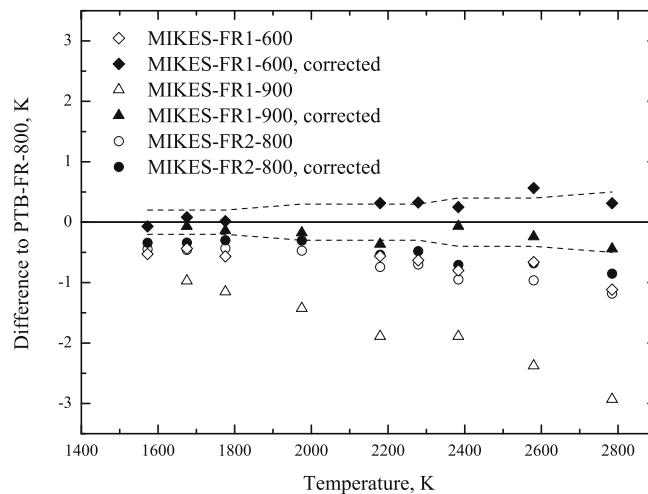

Fig. 5. Raw measurement results of the MIKES filter radiometers (open symbols) and the corresponding results corrected for radiance (closed symbols). The dashed lines represent the expanded uncertainty of PTB-FR-800.

4. Conclusions

The radiation temperature scales of PTB and MIKES were compared at the range of 1570–2770 K. The thermal radiation source used was a high-temperature blackbody of type BB3200pg formed by pyrolytic graphite rings. Four filter radiometers of MIKES, one filter radiometer of PTB and LP3 linear radiation thermometers of both PTB and MIKES were used. The filter radiometer of PTB was used as the temperature reference.

The agreement of the measured temperatures was within $k = 2$ uncertainty limits for the MIKES filter radiometers MIKES-FR1-600 and MIKES-FR2-800, and for the both LP3 radiation thermometers. The deviations of MIKES-FR1-800 and MIKES-FR1-900 from the reference values were larger, higher than the expanded uncertainties.

The results were also analyzed in terms of spectral radiance. The relative radiance deviation from the reference was found to be quite constant for each filter radiometer of MIKES. With the help of a calculated radiance correction, the agreement in temperature was significantly improved.

In the separate characterization of the interference filters and the detector, the geometries in the transmittance measurement setups should be carefully matched with the geometries used in the temperature measurements. The advantage of the FR2 type filter radiometer is that the filter and detector are characterized simultaneously in the same arrangement in which they are used in the temperature measurement.

References

- [1] H. Preston-Thomas, The ITS-90, *Metrologia* 27 (1990) 3–10.
- [2] F. Sakuma, L. Ma, J. Hartmann, Intercomparison of radiation temperature scales between PTB and NMIJ from 1100°C to 2500 °C, in: *Proc. SICE2002, 41th SICE Ann.Conf.*, Osaka, Japan, 2002, pp. 58–62.
- [3] N.J. Harrison, N.P. Fox, P. Sperfeld, J. Metzendorf, B.B. Khlevnoy, R.I. Stolyarevskaya, V.B. Khromchenko, S.N. Mekhontsev, V.I. Shapoval, M.F. Zelener, V.I. Sapritsky, International comparison of radiation-temperature measurements with filtered detectors over the temperature range 1380–3100 K, *Metrologia* 35 (1998) 283–288.
- [4] B.B. Khlevnoy, N.J. Harrison, L.J. Rogers, D.F. Pollard, N.P. Fox, P. Sperfeld, J. Fischer, R. Friedrich, J. Metzendorf, J. Seidel, M.L. Samoylov, R.I. Stolyarevskaya, V.B. Khromchenko, S.A. Ogarev, V.I. Sapritsky, Intercomparison of radiation temperature measurements over the temperature range from 1600 K to 3300 K, *Metrologia* 40 (2003) S39–S44.
- [5] K. Anhalt, J. Hartmann, J. Hollandt, G. Machin, D. Lowe, H. McEvoy, F. Sakuma, L. Ma, Comparison of high temperature scales of the NMIJ and the NPL with the scale of the PTB from 1300 K to 3200 K, in: D. Zvizdic, L.G. Bermanec, T. Veliki, T. Stašić (Ed.), *Proc. TEMPMEKO 2004, 9th Int. Symp. on Temperature and Thermal Measurements in Industry and Science*, FSB/LPM, Zagreb, Croatia, 2004, pp. 1063–1068.
- [6] M. Noorma, P. Kärhä, T. Jankowski, F. Manoocheri, T. Weckström, L. Uusipaikka, E. Ikonen, Absolute detector-based radiometric temperature scale, in: D. Zvizdic, L.G. Bermanec, T. Veliki, T. Stašić (Ed.), *Proc. TEMPMEKO 2004, 9th Int. Symp. on Temperature and Thermal Measurements in Industry and Science*, FSB/LPM, Zagreb, Croatia, 2004, pp. 101–106.
- [7] M. Ojanen, V. Ahtee, M. Noorma, T. Weckström, P. Kärhä, E. Ikonen, Filter radiometers as a tool for quality assurance of temperature measurements with linear pyrometers, *Int. J. Thermophys.* 29 (2008) 1084–1093.
- [8] D.R. Taubert, R. Friedrich, J. Hartmann, J. Hollandt, Improved calibration of the spectral responsivity of interference filter radiometers in the visible and near infrared spectral range at PTB, *Metrologia* 40 (2003) S35–S38.
- [9] D.R. Taubert, R. Friedrich, J. Hollandt, P. Sperfeld, J. Hartmann, Long-term stability of the spectral responsivity of filter radiometers at the PTB, in: D. Zvizdic, L.G. Bermanec, T. Veliki, T. Stašić (Ed.), *Proc. TEMPMEKO 2004, 9th Int. Symp. on Temperature and Thermal Measurements in Industry and Science*, FSB/LPM, Zagreb, Croatia, 2004, pp. 977–983.
- [10] J. Hartmann, K. Anhalt, B. Gutschwager, C. Monte, P. Sperfeld, D. Taubert, J. Hollandt, The PriTeRa facility of PTB for spectral radiance and irradiance calibrations and radiation thermometry in the range from -170 °C up to 3200 °C and from 200 nm up to 50 μ m, in: *Proc. NEWRAD 2008, Int. Conf. on New Developments and Applications in Optical Radiometry*, Daejeon, Korea, October 13–16, 2008, pp. 231–232.
- [11] J. Hartmann, High-temperature measurement techniques for the application in photometry radiometry and thermometry, *Phys. Rep.* 469 (2009) 205–269.
- [12] V.I. Sapritsky, B.C. Johnson, R.D. Saunders, L.V. Vlasov, K.A. Sudarev, B.B. Khlevnoy, V.I. Shapoval, I.A. Dmitriev, L.M. Buchnev, A.V. Prochorov, Precision high temperature blackbodies, in: R.E. Huffman (Ed.), *Proc. SPIE* 1764, 1992, p. 323–331.

- [13] P. Kärhä, A. Haapalinna, P. Toivanen, F. Manoochehri, E. Ikonen, Filter radiometry based on direct utilization of trap detectors, *Metrologia* 35 (1998) 255–259.
- [14] P. Kärhä, P. Toivanen, F. Manoocheri, E. Ikonen, Development of a detector-based absolute spectral irradiance scale in the 380–900 nm spectral range, *Appl. Opt.* 36 (1997) 8909–8918.
- [15] M. Noorma, P. Toivanen, F. Manoocheri, E. Ikonen, Characterization of filter radiometers with wavelength tunable laser source, *Metrologia* 40 (2003) 220–223.
- [16] R. Friedrich, J. Fischer, M. Stock, Accurate calibration of filter radiometers against a cryogenic radiometer using a trap detector, *Metrologia* 32 (1995/96) 509–513.
- [17] K. Anhalt, J. Hartmann, D. Lowe, G. Machin, M. Sadli, Y. Yamada, Thermodynamic temperature determinations of Co–C, Pd–C, Pt–C and Ru–C eutectic fixed-point cells, *Metrologia* 43 (2006) S78–S83.
- [18] J. Fischer, G. Neuer, E. Schreiber, R. Thomas, Metrological characterisation of a new transfer standard radiation thermometer. in: B. Fellmuth, J. Seidel, G. Scholz (Ed.), *Proc. TEMPMEKO2001, Int. Symp. on Temperature and Thermal Measurements in Industry and Science*, Berlin, Germany, 2001, pp. 801–806.
- [19] F. Sakuma, S. Hattori, Establishing a practical temperature standard by using a narrow-band radiation thermometer with a silicon detector, *Temp. Meas. Control Sci. Ind.* 5 (1982) 421–427.
- [20] P. Sperfeld, J. Metzendorf, N.J. Harrison, N.P. Fox, B.B. Khlevnoy, V.B. Khromchenko, S.N. Mekhontsev, V.I. Shapoval, M.F. Zelener, V.I. Sapritsky, Investigation of high-temperature black body BB3200, *Metrologia* 35 (1998) 419–422.
- [21] F. Manoochehri, E. Ikonen, High-accuracy spectrometer for measurement of regular spectral transmittance, *Appl. Opt.* 34 (1995) 3686–3692.