

A New Multistage Biofuel Drying System Integrated into an Industrial CHP-power Plant: Description of Process and Performance Calculations

Jukka-Pekka Spets, Helsinki University of Technology
Pekka Ahtila, Helsinki University of Technology

ABSTRACT

The drying of biofuels should be as effluent-free and energy-efficient as possible to ensure safe and economical operation. This paper presents a new multistage drying system (MSDS), that provides significant benefits when compared to conventional single dryer systems. Most promising, this new application is installed in integrated pulp and paper mills. The MSDS, simultaneously using secondary process energy, and back-pressure and extraction steams as the drying energy, enables a smaller volume flow of drying air than single dryer systems. Depending on the structure of the system, up to even 100 % of the drying air can be utilized as combustion air. The use of MSDS also enables an increase in power boiler capacity, which enhances the production of power and heat in combined heat and power (CHP) plants. For example, if the solid capacity increase of a biofuel boiler is 10 %, the plant would produce about 2.4 % more net heat and 16.4 % more net power at the generator's terminals, minus the power demand of the boiler - MSDS process. Additionally, the improvement in CHP can be attained with decreased emissions of unburned organic compounds and CO from combustion as a result of the improved quality of the biofuels. When compared to direct steam drying, the MSDS also better minimizes, or even eliminates, the formation of condensate from the drying operation. Equations in this article follow SI-units, unless separately mentioned.

Introduction

The multistage structure of wet biofuel drying systems was described earlier in an article "A new multistage drying system". The multistage drying system - steam boiler - integration is shown in figure 1.

In the secondary drying stage, the wet fuel is preheated and predried with warm air, which is heated up with secondary energy flows. The temperature of air in the direct contact drying stage is 70-80 °C, depending on the secondary energy resources of power plant or pulp mill. The outlet flow of wet drying air may be led into the atmosphere, because emissions from wood being dried in temperatures 100 °C have no practical meaning for the environment. The predried fuel is directed into the first hot drying stage, in which the temperature of atmospheric drying air is in region of 130 °C, the exact temperature depending on the back-pressure steam temperature of the power plant. From the first hot drying stage, the drying air is led through a gas warmer into the second hot drying stage. The biofuel from the first hot dryer is led into the second hot drying stage. The inlet temperature of the hot drying air during the second ... nth hot drying stages are 185 °C, depending on the temperature of steam extracted from the steam turbine. The hot drying stages are connected in series. The number of hot drying stages depends on the required moisture decrease of fuel before being led into the steam boiler furnace, and on the capacity of the secondary drying

stage to predry the wet fuel. The structure of the steam system with MSDS connected to a CHP-steam boiler is shown in Figure 2. The MSDS may have a cooling scrubber for decreasing the water content of drying air before leading this air staged into the steam boiler furnish, secondary and tertiary air registers. The rest of the combustion air, together with the drying air, is drawn from the atmosphere.

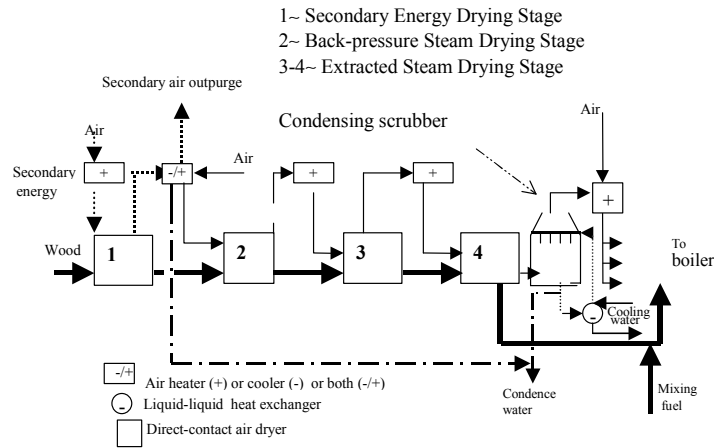

Figure 1. Principal scheme: the multistage drying system.

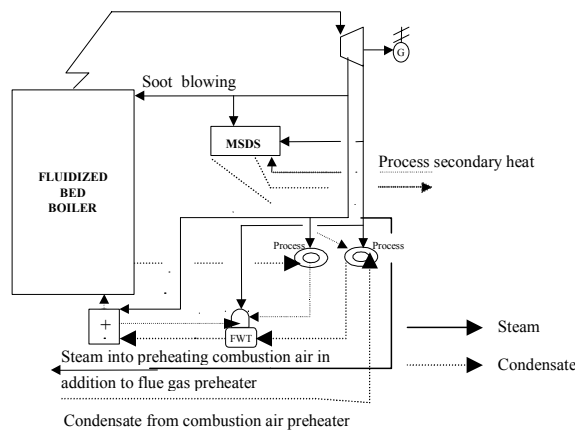

Figure 2. Multistage drying system (MSDS) connected to steam system in a CHP-plant.

The energy for drying is carried by the indirect heating of drying air. The dryers can be heated indirectly by steam to compensate for the energy lost by heating fuel into the adiabatic saturation temperature of incoming hot air and for heat losses into atmosphere. When drying stages and gas ducts are well insulated, heat losses into the atmosphere can be neglected in calculations. The specific energy consumption Φ_{SEC} of an adiabatic drying system (n pcs drying stages) is as follows:

$$\Phi_{SEC} = \sum_{i=1}^n (\Delta\Phi + \Phi_{Ex})_i / (\Delta\dot{m}'_{H_2O}) \quad , \quad (1)$$

where $\Delta\Phi$ is power for heating drying air before the drying stages, Φ_{Ex} is power for compensating heat losses to keep the drying action as adiabatic as possible in respect of drying air and $\Delta\dot{m}'_{H_2O}$ is the evaporated mass flow of moisture from fuel. The extra heating of drying stage Φ_{Ex} given as:

$$\Phi_{Ex} = \dot{m}'_{ds} * c_{p,ds} * (t_{s,i} - t_{i-1}) + \dot{m}'_{H_2O} * c_{p,H_2O} * (t_{s,i} - t_{i-1}) + \Phi_{im} \quad , \quad (2)$$

where \dot{m}' is the mass flow of solids or water of wet fuel in feed into the dryer, c_p is heat capacity of solids or water, t_s is the saturation temperature of hot drying air in dryer i , t_{i-1} is the outlet temperature of fuel from dryer $i-1$ or outdoors and Φ_{im} is the power needed for ice or snow warming and melting in winter in the secondary drying stage or in the first hot dryer.

The thermic efficiency η_{th} (%) of the drying stage is given as the relation of evaporation power of water to heat power consumption of the multistage drying system:

$$\eta_{th} = \sum_{i=1}^n (\Delta \dot{m}'_{H_2O} l(t_{s,i}))_i 100 / (\Phi_{Total}) \quad , \quad (3)$$

where $\Delta \dot{m}'_{H_2O}$ is the mass flow of evaporated water in dryer i , $l(t_{s,i})$ is the heat of evaporation of water in dryer i at saturation temperature $t_{s,i}$ and Φ_{Total} is the total energy consumption of MSDS¹.

Approximate description of drying kinetics of wood in multistage drying system

The multistage drying system can be connected to both single fuel and multifuel types of power boilers. The plans were to dry solid wood matter only before feeding it into the furnace of the power boiler. It is argued that to stop wood drying at fiber saturation point FSP, which is the moisture content of wood (w-%), under which all remaining water in wood is increasingly tightly bounded the lower moisture content the drying is reached (Stamm & Loughborough 1935). The fiber saturation point depends on the temperature of wood particles. It can be estimated by the well-known equation of Siau (1984). The rough estimation for the fiber saturation point of wood is 0.28 kg H₂O/ kg dry solid (0.22 kg H₂O/ kg wet wood). If the drying action is reached under the FST-point of wood, the drying starts to consume energy for loosing the binded water. That energy consumption may be taken from the increased mass flow of extracted steam from the steam turbine. The result is, that the internal power consumption of boiler-multistage drying system -integration increases and the output power of electricity decreases. The main intention of this article is to describe fully the process of the multistage drying system, while giving only a rough and simplified description of the drying kinetics. The drying phenomena of wood particles (regarded as a sphere) in a single drying stage of a continuous drying system is divided into two stages:

1. The initial heating of particles into the adiabatic saturation temperature (t_s) of incoming hot drying air. During that period no drying of particles occurs

¹ Note! S+ (n-1) H means MSDS with one secondary heat (S) and n-1 pxs steam heated drying stages (H). This notation has been used later in text.

2. After the initial heating of particles, the constant rate drying of particles starts at constant temperature t_s .

The drying phenomenon is calculated as a convective heat and mass transfer between a single wood particle and drying air. This is shown in equation (4):

$$\alpha_c (t_g - t_s)_{\ln} = \dot{m}''_{H_2O} l(t_s) \quad , \quad (4)$$

where α_c is a convective heat transfer coefficient through the outer area of particles, $(t_g - t_s)_{\ln}$ is the logarithmic mean value for temperature difference between drying air and the surface temperature of particles, \dot{m}''_{H_2O} is a mass flux of water vapor through the particle outer surface, and $l(t_s)$ is the heat of vaporization of water at temperature t_s .

The following validation exist for the initial heating of particles to the adiabatic saturation temperature t_s of incoming hot drying air:

$$\alpha_c (t_g - t_s) A_p \Delta\tau_{ih} = (\dot{m}_{p,s} c_{p,s} (t_s - t_{in}) + \dot{m}_{p,s} x c_{p,H_2O} (t_s - t_{in})) \quad , \quad (5)$$

where A_p is an outer surface area of a particle, $\Delta\tau_{ih}$ is a time period (s), $m_{p,s}$ is a solid mass of a single particle, x is the moisture content of particle / kg solid mass, c_p are the heat capacities for solid matter and water, and t_{in} is the temperature of a particle being fed into the drying stage.

During the initial heating ($\Delta\tau_{ih}$) of particles is when the initial cooling of the incoming hot drying air mass flow occurs, the logarithmic mean temperature is as follows:

$$(t_g - t_s)_{\ln,ih} = \frac{((t_{g,in} - t_s) - (t_{g,in} - \Delta t_{g,c} - t_s))}{\ln((t_{g,in} - t_s)/(t_{g,in} - \Delta t_{g,c} - t_s))} \quad , \quad (6)$$

where $t_{g,in}$ is the temperature of hot drying air entering to the drying stage, $\Delta t_{g,c}$ is the degrees hot air cools during the initial heating of a particle. Surface temperature t_s is kept constant as the adiabatic saturation temperature of hot air as long as the moisture content of a particle is minimum at fiber saturation point.

During constant rate drying, when the moisture content of a particle is at minimum at fiber saturation point, the logarithmic temperature can be explained as follows:

$$(t_g - t_s)_{\ln,D} = \frac{((t_{g,in} - \Delta t_{g,c} - t_s) - (t_{g,out} - t_s))}{\ln((t_{g,in} - \Delta t_{g,c} - t_s)/(t_{g,out} - t_s))} \quad , \quad (7)$$

where $t_{g,out}$ is the temperature of drying air from the dryer.

The particle is regarded as unshrunked during drying. For a drying time τ_D in one dryer, the following:

$$\Delta\tau_D = \frac{\dot{m}_{p,s} (x_0 - x_1)}{\dot{m}''_{H_2O} A_p} \quad , \quad (8)$$

where x_0 and x_1 are the inlet and outlet moisture contents of a particle / solid mass and $m_{p,s}$ is the mass of a dry solid particle.

The convective heat transfer coefficient α_c has the following equation:

$$\alpha_c = \frac{(Nu \lambda)}{d_p} \quad , \quad (9)$$

where Nu is a Nusselts number, λ is the heat conductivity of saturated air-water mixture at temperature t_s and d_p is an effective particle diameter.

For a sphere Nusselts number has a common correlation:

$$Nu = 2 + 0.6 Pr^{1/3} \sqrt{Re} \quad , \quad (10)$$

where Pr is a Prandlt's number and Re is a Reynolds number.

For a spheres, the Reynolds number has the following correlation:

$$Re = \frac{u_s d_p}{\nu} \quad , \quad (11)$$

where u_s is a slip velocity, which is a velocity difference between air and particle. For a big wood sphere ($d_p \geq 5$ mm) $u_s = u$, where u is a drying air velocity through the dryers cross-section, ν is a kinematic viscosity of saturated air-water -mixture.

The total drying time for a particle in MSDS with a certain change of moisture content is:

$$\tau_{Tot} = \sum_{i=1}^n (\Delta \tau_{ih} + \Delta \tau_D)_i \quad , \quad (12)$$

The adiabatic saturation temperature is a function of humidity and temperature of hot air stream. The corresponding partial pressure of water vapor in that saturated state can be calculated with Clausius-Clapeyron' equation. The integration gives:

$$\frac{p_{sat}}{p_{ref}} = \exp \left[\int_{T_{ref}}^{T_{sat}} \frac{M l dT}{R_g T^2} \right] \quad , \quad (13)$$

where M is molal mass of water, l is heat of evaporation of water at reference temperature and R_g is a gas constant.

The principle of the particle drying is summarized in Figure 3. The left side of Figure 3 shows, that the particle is surrounded by a thin film, which causes resistance to mass and heat transfer in drying action. The thin film is a saturated air-water vapor mixture. The temperature of the particle and thin film is t_s , which is the adiabatic saturation temperature of hot air flow, as long as the moisture content of the particle at least corresponds to the fiber saturation point FSP.

Heat lossess into atmosphere

The MSDS is regarded as adiabatic - heating of biomass in the dryer's space is compensated by extra heating of drying air. In reality, heat losses occur through the dryers' shells and duct walls into atmosphere. Both forms of heat transfer, convection and conduction, are included in the calculation of total heat loss through the (insulated) wall of the process equipment to atmosphere. The total heat penetration number k can be calculated as:

$$k = \frac{1}{\frac{1}{\alpha_s} + \frac{s_1}{\lambda_1} + \frac{s_2}{\lambda_2} + \frac{1}{\alpha_u}} \quad , \quad (14)$$

where α_s is the heat transfer coefficient from drying air into the inside surface of the wall of the process equipment, s_1/λ_1 is thickness of wall / heat conductivity, s_2/λ_2 is thickness of insulation layer / heat conductivity and α_u is coefficient of heat transfer from surface

insulation into the surrounding atmosphere. In recovery boiler plants the value of α_u is detected at about $12 \text{ W/m}^2 \text{ }^\circ\text{C}$. For compounded steel λ_1 is $43 \text{ W/m}\cdot\text{K}$ and for insulation material λ_2 is $0.038 \text{ W/m}\cdot\text{K}$. The wall thickness s_1 for air ducts and dryers can be set in calculation at about 3 mm and for insulation thickness s_2 , at $100\text{-}200 \text{ mm}$. α_s can be calculated according to Incropera and Dewitt (1996). The heat power through a wall with surface area A , the inner temperature of drying air t , and the open-door temperature t_{out} can be calculated as:

$$Q = k A (t - t_{\text{out}}) + \Phi_r \quad (15)$$

where Φ_r is the radiative heat power from surface s into the atmosphere. Φ_r can be calculated:

$$\Phi_r = \varepsilon \sigma (T_s^4 - T_{\text{out}}^4) \approx 4 \varepsilon \sigma \bar{T}_{s,\text{out}}^3 \quad (16)$$

where ε is an emissivity factor ($\varepsilon \approx 0.09$ for steel plate), σ is Boltzmann's constant and $\bar{T}_{s,\text{out}}$ is the average value of temperature limits (K).

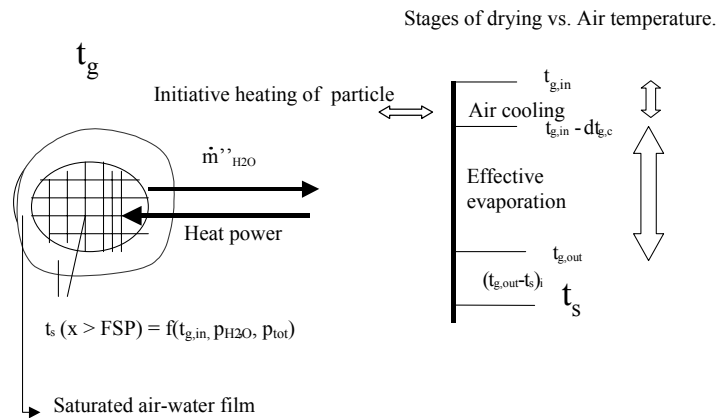

Figure 3. Particle drying.

Heat losses according to Eq. (15) depends on process values and equipment dimensions. For MSDS (S+2H) the highest heat losses into atmosphere are (outdoor temp. $10 \text{ }^\circ\text{C}$, 100 mm insulation) about 0.6 kW/m (insulated length, $v_{\text{air}} = 15 \text{ m/s}$) for air ducts and 40 W/m^2 (area of dryer's mantel, at average temperature). The heat losses from air ducts decreases about 48% , when insulation thickness is increased from 100 mm to 200 mm . The MSDS increases the boiler efficiency η_{Boil} (% (steam effect / fuel effect)) in one specified process calculation from 92.6% to 94.9% .

CALCULATION

Process values for boiler, steam circulation and MSDS are shown in Tables 1 and 2.

Table 1. Process values for fluidized bed boiler (FBB) and steam system.

Steam process:		
The efficiency of high and low pressure parts of steam turbine:	88	%
The efficiency of generator:	98.5	%
Fluidized bed boiler:		
Flue gas temperature from cooled furnace:	827	°C
Excess air coefficient in combustion:	1.2	
Radiation losses into environment (assumed):	1.5	% (of fuel effect)
Preheated combustion air (CA) temperature before combustion:	136	°C
Outdoor air relatively humidity at different temperatures:	60	%
Drying air humidity after scrubber:	7.3	vol-%, wet air
Drying air temperature before preheating:	40	($t_{g,out}$) _n °C
(Note: Temperature with aftercondensation (Without aftercondensation from the last drying stage number n)		
Feed water (FW) and back-pressure (B-P) steam pressures:	3.4	bar(A)
Flue gas temperature from boiler unit:	181	°C
Condensate temperature / pressure from processes:	80.2	°C / 1 bar(A)
Feed water temperature into boiler:	178	°C
Flue gas temperature after CA-preheater:	120	°C
Live steam / extraction steam pressures from turbine:	90 bar(A) / 9.5 bar(A)	
Live steam temperature:	525	°C
Fuels: Wood:	$\dot{m}'_o = 13$ kg/s (tot)	Moisture: (Initial 57.5 w-% _{H2O, tot})
Peat:	$\dot{m}'_o = 9.5$ kg/s (tot)	(48 w-% _{H2O, tot} into furnace)
Heat capacity of dry peat solids:	1.6	kJ/kgK (Constant)

Table 2. Initial data for multistage drying system (MSDS).

Outdoor air relatively humidity (RH):	60 % (at outdoor temperature)
Dry air composition:	
N ₂ * (Raw nitrogen: N ₂ *= N ₂ +CO ₂ +Ar)	79.05 vol-%
O ₂	20.95 vol-% ; $\sum = 100$ vol-%
Reference temperature for enthalpy balance:	0.01 °C
Heat capacity of dry wood solids:	(x+0.324)*4.184/(1+x) kJ/kg°C
Slip velocity in every dryers:	2 m/s
Drying air temperature into secondary stage S:	70 °C
Drying air temperature into 1 st / 2 nd -n th stages (H) :	130 °C (1H) / 185 °C (2H-nH)
Drying sequence for wood is indicated as	
xx-yy ... zz :	xx ~ moisture in MSDS yy ~ moisture out sec. energy stage zz ~ moisture out MSDS

INTERNAL POWER CONSUMPTION OF MAIN PROCESS EQUIPMENT IN FBB-MSDS -INTEGRATE

Fluidized bed boiler (FBB) combusts wood and peat. Wood is dried and peat is fed into the furnace at 48 w-% moisture content. In one process case the internal power consumption (IPC) value for the total integration is 21.9 kW_e / MW steam effect of FBB, of which FBB's value is 18.5 kW_e / MW steam effect of FBB and MSDS's (S+2H) value is 3.4 kW_e / MW steam effect of FBB, when wood is dried from 57.5 w-%_{H2Otot} to 22 w-%_{H2Otot}. The corresponding percentage distribution of IPC for the main process equipment in total integration is: All air fans (49.6%), all water pumps (42.5%), fuel feeding equipment (0.5%) and electrostatic precipitator (7.4%). For calculating fuel transport and feeding equipment: FBB has two separate main belt conveyors for wood and peat. MSDS has beltconveyors before and between dryers, and a screw feeder / dryer and belt conveyor from the last dryer to the main belt conveyor of wood into FBB.

CALCULATED RESULTS ²

Net power and net heat productions of FBB-MSDS –integration as function of end moisture of wood with initial wood moisture content 57.5 w-%_{H2O,tot} are shown in Figure 4. Compared to reference state (a power plant without wet wood drying system), the wet wood drying increases net power production and decreases net heat for mill. The net heat decrease is because of consumption of back-pressure and extracted steams from steam steam turbine for drying operation.

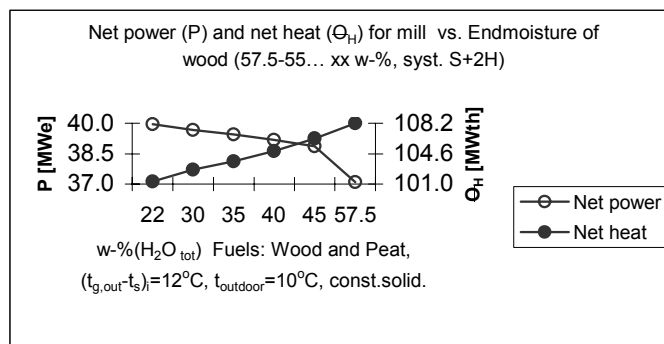

Figure 4. CHP-production values vs. end moisture of wood from MSDS. Combustion with initial solid amount as in boiler without MSDS)

The solid increase in combustion required to maintain the net heat Φ_H for mill equal than earlier without MSDS, if the secondary energy heated drying stage efficiency is not high enough, is shown in Figure 5.

² Note! Heat losses into atmosphere are not taken in account in all results calculated in Figures 5 ... 10.

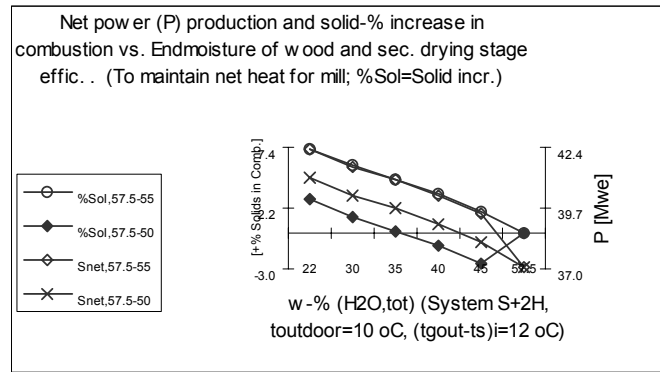

Figure 5. Solid increase (%) in combustion to maintain initial net heat for mill.

The specific energy consumption Φ_{SEC} values for MSDS vs. the outdoor temperature and the number of hot dryers are shown in Figure 6. With temperatures 0 °C, Φ_{SEC} includes the heat of ice melting, when, it is assumed, that all moisture in wet fuel is frozen. Φ_{SEC} of S+3H is smaller than Φ_{SEC} of S+ 2H. The corresponding thermic efficiencies η_{th} vs. number of drying stages and outdoor temperature with sec. energy. dryer's efficiency 57.5-55 w-%H₂Otot are: $\eta_{th}(S+2H, 10^{\circ}C) = 64.1\%$, $\eta_{th}(S+2H, -15^{\circ}C) = 50.7\%$ and $\eta_{th}(S+3H, 10^{\circ}C) = 65.8\%$.

Two different values for specific energy consumptions Φ_{SEC} and Φ_{SECRed} are shown in Figure 7. Φ_{SECRed} contains only the energy consumptions of hot dryers, when the value of secondary energy is set as 0.

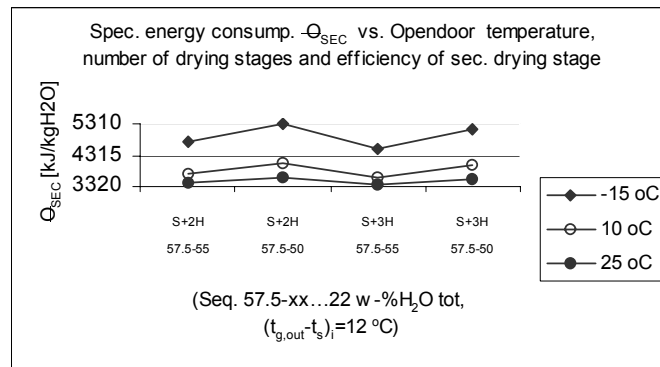

Figure 6. Specific energy consumption Φ_{SEC} of MSDS vs. Outdoor temperature and Number of Steam Heated Drying Stages (S)

It can be seen from the Figure 7, that the more the water is evaporated, the smaller the specific energy consumption Φ_{SEC} of drying is. With effective moisture reduction of wet fuel in secondary energy heated at stage S, the reduced specific energy consumption Φ_{SECRed} of drying decreases more than the heat of evaporation of water under normal state conditions (2500 kJ/kgH₂O, 1.013 bar and 0 °C).

The mass flows of condensate (water) from MSDS (S+2H, (t_{g,out}-t_s)=12 °C) vs. outdoor temperature is quite stable (about 2.7 kg/s), when the outdoor temperature varies between -15 and 15 °C and wood drying sequence is 57.5-55...22 w-%H₂O,tot. The temperature of condensate flow varies at the same time between 43 and 49 °C. These

condensates are from the preheater of first hot drying stage's drying air with secondary dryer's exit drying air, and from aftercondensing scrubber ($t_{g,AFTC} = 40\text{ }^{\circ}\text{C}$). It's possible to operate MSDS totally as a closed system: MSDS contains only hot air drying stages and has no condensing scrubbers. CHP-production has no significant differences between drying air feed temperatures of $130\text{ }^{\circ}\text{C}$ and $185\text{ }^{\circ}\text{C}$ in the second hot drying stage in preceding MSDS. But there is one difference: the mass flow of drying air. The decrease of drying airflow over 25 % in higher inlet temperature system causes savings in investment costs, because of the smaller size of process equipment.

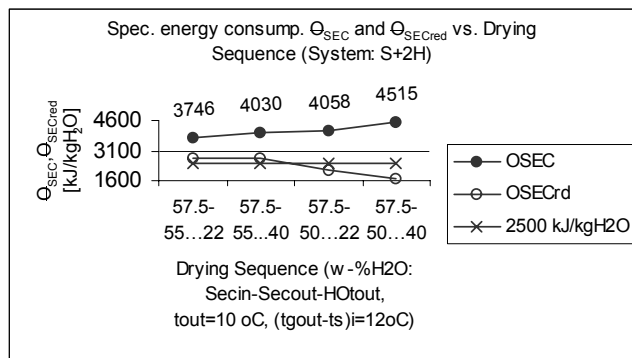

Figure 7. Specific (Φ_{SEC}) and reduced (Φ_{SECred}) specific energy consumptions of MSDS vs. Drying sequence in MSDS (S+2H)

The evaporation fluxes of water from wood spheres in different drying stages in drying sequence 57.5-55...30 w-%H₂O_{tot} vs. diameter of wood sphere, are shown in Figure 8.

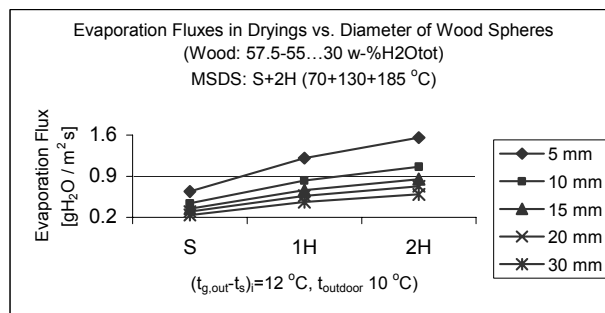

Figure 8. Evaporation fluxes of water vs. Wood sphere diameter

The calculated mass fluxes of evaporated water in Figure 8 are of same order of magnitude than earlier as that reported earlier by VTT Energy in Finland (1996, thermal gauge) and Laytner F. et al. at University of British Columbia (1992, laboratory scales test with wood wafer in a single dryer). Total drying times vary as a function of sphere diameter, moisture reduction and the number of hot dryers. With drying sequence 57.5-55...22 w-%H₂O_{tot} and MSDS (S+2H, ($t_{g,out}-t_s$)_i=12 °C, t_{out} =10 °C), the corresponding calculated total drying times of spheres are 6 min (\varnothing 5 mm), 29 min (\varnothing 15 mm) and 85 min (\varnothing 30 mm), respectively.

Discussion

The energy balances are calculated for adiabatic drying system. When the different heat losses are taken account, the calculation is complicated, because the surface temperature of wood particles is then changed the dryer's inside space. The calculations use the assumptions that the moisture content of particles is uniform and that the surface temperature t_s is constant during drying action above the fiber saturation point of wood particles. The third simplification is that heat conductivity λ (W/mK) of wet wood is ∞ . Because Excel-calculation has it's capacity limits, the adiabatic saturation temperatures of hot drying air have been calculated with Clausius-Clapeyron - calculation file as process variables operating as functions of variable $(t_{g,out}-t_s)_i$ and outdoor temperature. To simplify the calculations, it was deemed wise to set temperature differences $(t_{g,out}-t_s)_i$ the same in all drying stages in MSDS.

Conclusion

The multistage drying system (MSDS) gives good chances of drying large portions of wet fuel before combustion and of feeding the humid drying air flow along a staged combustion air flow into the combustion unit. The multistage drying system also gives an excellent chance to utilize secondary energy flows in drying. To keep convective, conductive and radiative heat losses into the atmosphere low, the process equipment has to have a high level of insulation. MSDS installation in the example power plant could enable an increase of incomes from power production 7.8 % (constant solids in combustion) and 16.4 % (10% increase in solids in combustion). Corresponding increases in monetary bruttovalues per year (8000 h) are about USD 0.7 million (constant solids) and USD 1.5 millions (+10% increase in solids), when the power price is USD 30 / MWh electricity. Peat can be compensated with predried wood residues as fuel in the example power plant. If peat fed in combustion decreases from 9.5 kg/s to 6.5 kg/s, then the costs of peat decreases according to a rough estimate, by about USD100.000 / month in wintertime, when the peat cost is USD 5.1 / MWh peat (corresponding < 100 km transport distance). The benefits can be reach 100 %, when MSDS is installed in a new power plant. The power boiler design criteria can be modified to correspond to smaller flue gas mass flows, when wet wood fuel is predried outside the power boiler furnace. Power boiler dimension reductions cause greater savings in investment costs, when compared to power boilers without wet wood predrying systems before combustion.

References

Ahtila, P. 1997. *Optimization of Recovery Boiler Plant Air Systems by New Design Method and Process Integration*. Helsinki University of Technology, Mechanical Engineering Series No. 127, Academic Dissertation. Espoo.

Emission measurement in Existing Power Plant. Kullaa. Finland. January 2000. (Not published).

Energy Review. 1/2000. Ministry of Trade and Industry. Oy Edita Ab. Helsinki. (In Finnish).

- Ganter, P. & Kötting, J. 1999. "Planung und Wirtschaftlichkeit einer Holzfeuerungsanlage". *BWK* 51(1-2): 51-54.
- Haaga, K. 1982. *Tuning of Peat Firing Power Plant*. Tech. University of Tampere, Master thesis. (In Finnish).
- Impola, R., Saastamoinen, J., Fagernäs, L. 1996. *Characterization of Drying Parameters for Solid Fuels*. TEKES/Bioenergy Research Program. Final Report. Jyväskylä, Finland. (In Finnish).
- Incropera, F. P. & DeWitt, D. P. 1996. *Fundamentals of Heat and Mass Transfer*. 4th edition. John Wiley & Sons. USA.
- Lampinen, M. 1996. Lecture: Mass Transfer. 94 HUT, Department of Energy Engineering. Lab. of Applied Thermodynamics. Otaniemi, Espoo. (In Finnish).
- Lampinen, M. 1998. *582 Principles of Thermodynamics*. Otatiето Oy. Tammer-Paino Oy. Tampere, Finland. (In Finnish).
- Laytner, F. et al. 1992. "Kinetics of wood wafer drying." In *Drying '92*. Edited by A.S. Mujumdar. Department of Chemical Engineering. University of British Columbia. Vancouver, Canada. Elsevier Science Publishers.
- Nokian Ilmastointi. 198x. *Air Technology, Air Resistance of Ducts*. S011.05. (In Finnish).
- Nyman, J. 1973. *Design of Conveyers - Numerical Data*. Duplicate 1-73. Dept. of Mechanical Process Technology. University of Oulu, Finland. ISBN 951-42-0128-0. (In Finnish).
- Reyes, V. 1997. "Electrical Operation of Precipitation." In Parker ed. *Applied Electrostatic Precipitation*. 1st Edition. Blackie Academic & Professional. London.
- Stamm, A. J. & Loughborough, W. K. 1935. "Thermodynamics of the Swelling of Wood". *The Journal of Physical Chem.* 39(1): 121-132.
- Siau, J. F. 1971. *Flow in Wood*. Suracuse University Press. New York.
- Siau J. F. 1984. *Transport Processes in Wood*. Springer Verlag. Berlin.
- Spets, J.-P. 2001. *A New Multistage Drying System*. In 1st Nordic Drying Conference in Trondheim, 27th-29th June. Norway.
- WBPI. 1992. *Wood Dryer Emissions*. July: 37-39.