

Publication II

R. C. D. Paiva and H. Penttinen. Cable matters: Instrument cables affect the frequency response of electric guitars. In *Proc. 131st Audio Engineering Society Conv.*, New York, USA, paper number 8466, Oct. 2011.

© 2011 Copyright Holder.

Reprinted with permission.



Audio Engineering Society Convention Paper 8466

Presented at the 131st Convention
2011 October 20–23 New York, USA

This paper was peer-reviewed as a complete manuscript for presentation at this Convention. Additional papers may be obtained by sending request and remittance to Audio Engineering Society, 60 East 42nd Street, New York, New York 10165-2520, USA; also see www.aes.org. All rights reserved. Reproduction of this paper, or any portion thereof, is not permitted without direct permission from the Journal of the Audio Engineering Society.

Cable matters: instrument cables affect the frequency response of electric guitars

Rafael Cauduro Dias de Paiva^{1,2} and Henri Penttinen¹

¹Aalto University School of Electrical Engineering, Department of Signal Processing and Acoustics, Espoo, Finland

²Nokia Technology Institute INdT, Brasilia, Brazil

Correspondence should be addressed to Rafael Cauduro Dias de Paiva (rafael.dias.de.paiva@aalto.fi)

ABSTRACT

This paper presents analysis results of the effects an instrument cable has on the timbre of an electric guitar. In typical, well-designed audio equipment with proper impedance buffers, the effect of the cable can be considered insignificant at audio frequencies. In contrast, magnetic pickups used in electric guitars, act as resonating low-pass filters. The cable is attached to a resonating electrical circuit and hence its impedance characteristics can influence the system. The simulation and measurement results show that the capacitance of an instrument cable affects the frequency response of the system, whereas the effects of the inductance and series or parallel resistance are negligible. The largest shift in the resonant frequency for the measured cables was 1.4 kHz.

1. INTRODUCTION

In typical audio equipment the effect of a cable is minimized with proper impedance matching. Most modern audio equipment has a low output impedance ($< 150\Omega$), therefore connections with low output impedance and high input impedance are often used. This way the influence of the connection and cable is minimal on the distortion and high-frequency content. However, in the case of high impedance microphones or electric guitars the output impedance is high and hence creates a system where the cable interacts more easily with the output and input connections. Especially for long connections, sys-

tems with high output impedances are more susceptible to attenuation of high-frequencies and signal level than low output impedance systems. In the case of the electric guitar the instrument cable connecting the guitar to the effect unit or amplifier is typically 3 m to 9 m long. Often low impedance cables are used when the connection exceeds 15 m. One of the goals of the paper is to find out if the instrument cables typically used with electric guitars affect the timbre of the electric guitar.

Previous studies on the effects of cables concentrate on high fidelity audio systems [1, 2]. In this case the cable impedance interacts with the loudspeaker impedance and

low inductance cables are often used [1]. Additionally, the amplitude of the current in this type of cable may affect their phase response [2, 3].

Ideally, the guitar's magnetic pickups capture just the vibration of the strings. However, the pickups also affect the timbre of the guitar via the following physical phenomena. The first is similar to the effect of the plucking position, in which the position of the pickup creates a comb-like filter [4, 5, 6]. Additionally, the pickup has nonlinear properties that enhance the harmonics of the vibrating string [7, 8]. Most importantly, magnetic pickups have an equivalent circuit that is sensitive to the impedances that are connected to it [9, 10]. The equivalent circuit of magnetic pickups comprise of a series resistor and an inductor, as well as a parallel resistor and a capacitor. This equivalent circuit is responsible for the frequency response of each pickup, and by connecting an instrument cable to it, this frequency response is modified. Models for this behaviour are important for synthesis of musical sounds [11, 12, 13].

The objective of this work is to investigate the effect of instrument cables on the timbre of electric guitars. For that purpose 10 cables of different lengths and produced by different manufacturers were measured. The measurements were conducted both for determining the parameters for the equivalent circuit for the cables as well as for determining the effect of the instrument cable when connected to a guitar pickup.

This paper is organized as follows. Sec. 2 presents an analysis of the equivalent circuit of a coaxial cable. This analysis starts with the assumption of distributed symmetrical capacitance and simplifies the model using circuit analysis tools. Sec. 3 presents the measurement setup used for conducting the experiment. The measurement results are presented in Sec. 4, where the analysis of the most important parameters in guitar cables are presented based on changes in the pickup frequency response. Sec. 5 concludes the paper.

2. EQUIVALENT CIRCUIT ANALYSIS

Coaxial cables are the most commonly used cable type in electric guitars. Fig. 1 shows the typical parts of a coaxial cable. They are built with two conductors. The first one is placed at the center of the cable, and is referred here as the centre core. The second one is the metallic shield, which is separated from the first one by a dielectric insulator, surrounding both the centre core and the dielectric insulator. The cable has an additional

plastic or fabric jacket for electrical insulation from the external environment, and for mechanical protection of the cable parts. In typical connections, the centre core is responsible for transporting the audio signal, and the metallic shield is connected to the ground of the electrical circuits.

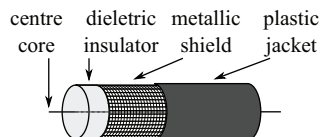

Figure 1: Parts of a coaxial cable (adapted from [14]).

2.1. Distributed cable impedance

Interestingly, since two conductors separated by a dielectric insulator form a capacitance, the configuration of a coaxial cable also creates a capacitance between the shield and the centre core. Additionally, as any electrical conductor, a coaxial cable would have a series resistance, representing ohmic losses, and a series inductance. Finally, real dielectric materials are not perfect insulators, hence a large resistance may be observed between the centre core and the metallic shield [15].

The model in Fig. 2 presents an equivalent circuit representing the above mentioned cable setup. This model is adapted from [15] to be symmetric. In this model, a distributed capacitance is applied, so that the cable impedance is separated in N different sections. The reason for the distributed capacitance is that for each infinitesimal section of a coaxial cable, there would be a series resistance and inductance, as the current is allowed to flow over any point of the distributed capacitance. A capacitor and a resistor are added at the input of the distributed impedance model to make the model symmetric, as in a real cable.

The distributed capacitance representation in Fig. 2 is supported by its physical explanation. However, a complete circuit analysis of this model would be highly complex and the optimization of the model parameters to fit a specific cable would be difficult. In order to avoid that kind of complexity, it is desirable to obtain a simpler equivalent circuit with fewer elements. A simplification can be obtained using a Δ -Y transform [16]. As the circuit in Fig. 2 can be decomposed into the Δ or Y sections in Fig. 3, it is convenient to derive the relationship between them. The Δ section in Fig. 3 (a) has impedances

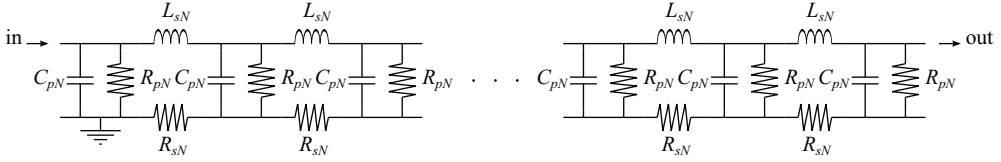

Figure 2: Cable model with distributed capacitance divided in N stages.

$Z_{s\Delta}$ and $Z_{p\Delta}$ as the series and parallel impedances, while the Y section in Fig. 3 (b) has Z_{sY} and Z_{pY} as the series and parallel impedances. The $Z_{s/pY/\Delta}$ impedances are given by

$$Z_{sY} = \frac{Z_{s\Delta}Z_{p\Delta}}{Z_{p\Delta} + Z_{p\Delta} + Z_{s\Delta}}, \quad (1)$$

$$Z_{pY} = \frac{Z_{p\Delta}Z_{p\Delta}}{Z_{p\Delta} + Z_{p\Delta} + Z_{s\Delta}}. \quad (2)$$

The Δ circuit components are given by

$$Z_{s\Delta} = j\omega L_{s\Delta} + R_{s\Delta}, \quad (3)$$

$$Z_{p\Delta} = \frac{R_{p\Delta}}{j\omega C_{p\Delta} R_{p\Delta} + 1}, \quad (4)$$

where ω is the angular frequency in rad/s, $j = \sqrt{-1}$ is the imaginary unity, $L_{s\Delta}$, $R_{s\Delta}$, $C_{p\Delta}$ and $R_{p\Delta}$ are the series inductance, series resistance, parallel capacitance and parallel resistance for the Δ connection in Fig. 3 (a), respectively. The Y circuit components are given by

$$Z_{sY} = j\omega L_{sY} + R_{sY}, \quad (5)$$

$$Z_{pY} = \frac{R_{pY}}{j\omega C_{pY} R_{pY} + 1}, \quad (6)$$

where L_{sY} , R_{sY} , C_{pY} and R_{pY} are the series inductance, series resistance, parallel capacitance and parallel resistance for the Y connection in Fig. 3 (b). As the parallel impedance is for the studied cases much larger than the series impedance $Z_{p\Delta} \gg Z_{s\Delta}$, Eq. 1 and Eq. 2 can be simplified as

$$Z_{sY} = \frac{Z_{s\Delta}}{2}, \quad (7)$$

$$Z_{pY} = \frac{Z_{p\Delta}}{2}. \quad (8)$$

This implies that the elements in the Y connection can be written as a function of the elements in the Δ connection,

as

$$R_{sY} = \frac{R_{s\Delta}}{2}, \quad (9)$$

$$L_{sY} = \frac{L_{s\Delta}}{2}, \quad (10)$$

$$R_{pY} = \frac{R_{p\Delta}}{2}, \quad (11)$$

$$C_{pY} = 2C_{p\Delta}. \quad (12)$$

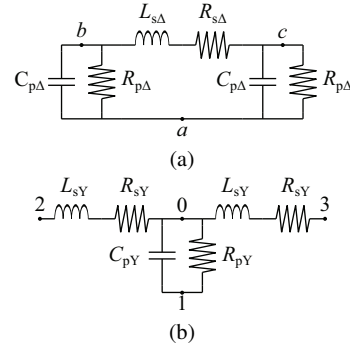

Figure 3: Delta star transformation used for simplifying the distributed capacitance cable model.

By using the results of Eq. 7 and Eq. 8, the circuit in Fig. 2 can be simplified as shown in Fig. 4. The components of this circuit are assumed to have equal value through all stages. This assumption is made considering a cable that is produced with the same type of material along its length. In Fig. 4, the equivalent circuit with N stages is separated into $N/2$ stages having a Y connection (highlighted in the figure with the dotted lines). Once the Δ equivalent for each of these stages has been calculated, the parallel impedance elements are connected in parallel to other parallel elements, and can thus be simplified.

The same procedure is repeated again, until a simplified circuit containing only three elements is obtained. Finally, the series impedance of the simplified circuit is N times larger than the one with N stages, while the parallel impedance is $2/(N + 1)$ times smaller.

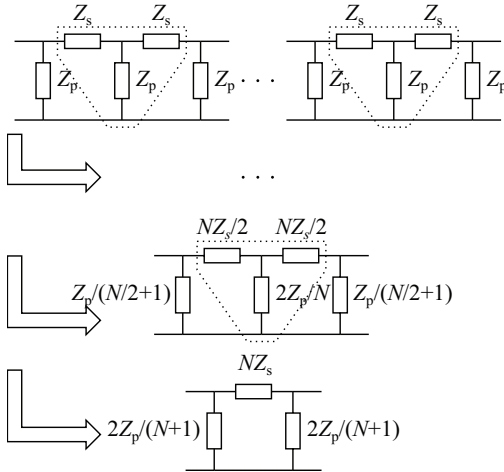

Figure 4: Cable equivalent circuit simplification using the Δ -Y transform.

The circuit analysis shown in Fig. 4, Eq. 3, and Eq. 4 indicates that any cable model with N stages can be simplified as an equivalent circuit model shown in Fig. 5. In this case the components of a N stage circuit model would be related to the simplified circuit model as

$$R_{sN} = R_s/N, \tag{13}$$

$$L_{sN} = L_s/N, \tag{14}$$

$$R_{pN} = R_p \frac{N+1}{2}, \tag{15}$$

$$C_{pN} = C_p \frac{2}{N+1}. \tag{16}$$

2.2. Open/short circuit impedance

The values of the cable parameters for the equivalent circuit can be obtained through two simple measurement setups. In the first one no load is connected to the cable, while in the second the output of the cable is short circuited.

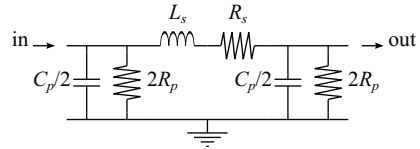

Figure 5: Simplified symmetric cable model.

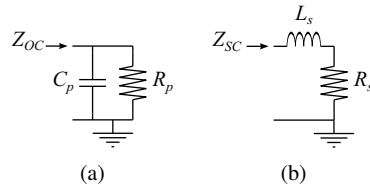

Figure 6: Equivalent circuit when measuring the impedance in (a) open circuit and (b) short circuit conditions.

The open circuit impedance can be determined by analyzing the cable circuit model in Fig. 5 with no load connected to the output. In this case the cable impedance is composed of two parallel sections. The first one is the parallel input impedance, formed by $2R_p$ and $C_p/2$. The second one is the parallel output impedance, again with $2R_p$ and $C_p/2$ in series with R_s and L_s . As the impedance of the series components is negligible when compared to the parallel elements $|Z_p| \gg |Z_s|$, they can be ignored in the open circuit analysis. Thus, Fig. 6 (a) presents the equivalent circuit for the open circuit measurement setup.

For the short circuit case, the same type of analysis was used as for the open circuit setup. When the output of the cable is short-circuited, the output parallel impedance may be ignored, and the equivalent circuit model will be composed by two parallel sections, one composed of the elements $2R_p$ and $C_p/2$, and the other with R_s and L_s in series. As the impedance of the elements R_s and L_s is much lower than the ones of $2R_p$ and $C_p/2$, $|Z_p| \gg |Z_s|$, the parallel resistance and capacitance can be neglected. Therefore, Fig. 6 (b) shows the resulting equivalent circuit.

3. EXPERIMENTAL MEASUREMENT SETUP

Cable measurements were performed in order to determine each parameter of the model in Fig. 5 C_p , R_p , R_s ,

and L_s , in a simplified manner. The first one is the open circuit condition, where the output of the cable is not connected, while the impedance is measured at the input, as shown in Fig. 7 (a). This setup is used to measure C_p and R_p as in Fig. 6 (a). The second one is the short circuit condition, where the output of the cable is short-circuited, while the impedance is measured at the input, as shown in Fig. 7 (b). This setup is used to measure L_s and R_s as in Fig. 6 (b).

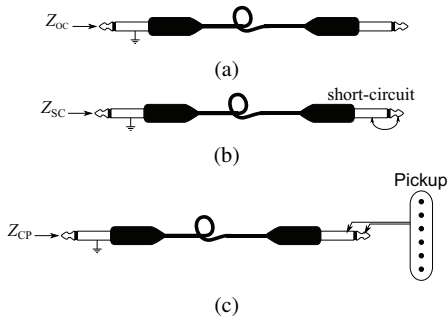

Figure 7: Measurement setup for (a) open circuit, (b) short circuit, and (c) cable with pickup conditions.

The effect of the cable on the pickup frequency response is evaluated using the measurement setup shown in Fig. 7 (c). In this measurement setup the combined impedance of a pickup connected to the cable is measured, which indicates how the resonance of a pickup is changed.

In all the measurement setups, the measurements were performed using either the LCR-meter Escort ELC 2260, or the Limp software produced by Arta Software [17] with an external Motu Ultra Lite audio interface. The LCR-meter is used for measuring the cable parameters in the open/short circuit conditions. With the LCR-meter, the measurements are performed with a single frequency, which can be either 120 Hz or 1000 Hz, considering a combination of resistance, inductance, and capacitance connected in series or in parallel.

The Limp software was used to measure the impedance of a Fender MP112 pickup when connected to an instrument cable. This software was used with an external Motu Ultra Lite audio interface, which fed a signal into the system under measurement Z , which consisted of the measurement setup presented in Fig. 7 (c). In this

measurement setup, a series resistance R_M is included as shown in Fig. 8 and two signals are measured at the input of the external audio interface. With the information of the voltages $V_0(f)$ and $V_1(f)$ obtained from the audio interface as in Fig. 8, the complex impedance Z can be measured for each frequency point f as

$$Z(f) = \frac{V_1(f)}{V_0(f) - V_1(f)} R_M. \quad (17)$$

As V_1 and $V_0 - V_1$ need to be measured, it is convenient to choose R_M with the same order of magnitude as Z , so that the magnitude of the voltages is similar, and the measurement signal-to-noise ratio is as high as possible.

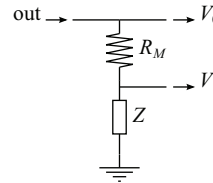

Figure 8: Measurement setup using Limp software.

4. MEASUREMENT RESULTS

This section presents the measured results for 10 different instrument cables. Table 1 presents a list of the cables with the lengths l and the label used for describing them in this section. Cables of different manufacturers were chosen, and the list includes a coiled cable (C9).

Table 1: List of cables that were used in the experiment.

Label	Manufacturer/model	length l (m)
C0	Reference cable	0.3
C1	No name	2.5
C2	Cordial CIK 122	3
C3	Proline BC328	3
C4	Elixir Cables	6
C5	Cordial CGK 122N	6
C6	Fender	6
C7	Planet Wave	6
C8	Proline BC313	6
C9	Vox Coil Cord VCC-90BK	9

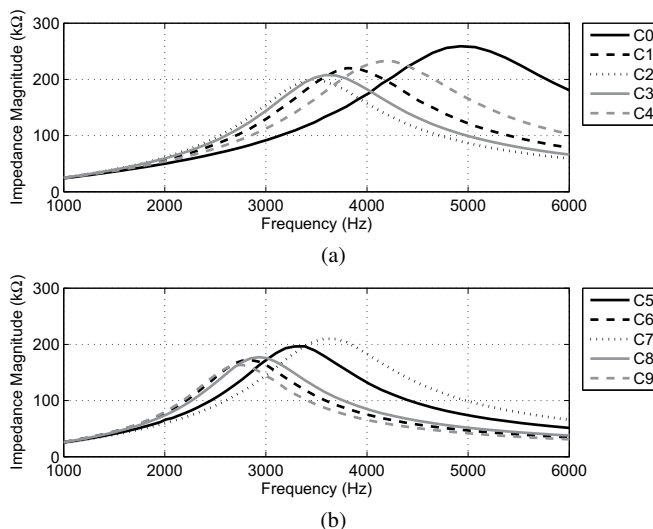

Figure 9: Impedance magnitude measurements of 10 different cables connected to a Fender pickup.

Table 2 shows the complete set of results containing measured parallel capacitance C_p , parallel resistance R_p , series inductance L_s , and series resistance R_s . The results were obtained with the Escort LCR-meter, so that R_s was obtained at 120.0 Hz, whereas C_p and L_s were obtained at 1000.0 Hz. The measurement frequency was chosen in order to obtain the most consistent results. The resistance of R_p was not obtained due to limitation in the range of the measurement instrument, but it can be neglected, firstly because the guitar pickup parallel resistance is usually lower than 3 MΩ [10] and usual effects/preamp circuits have an input resistance of 0.5 to 1 MΩ [18, 19], which makes the effect of R_p negligible at audio frequencies.

In Table 2 it is possible to observe that as a general trend the components are proportional to the cable length. For example, the longest cable C9 has the largest capacitance C_p , while the shortest cable C0 has the smallest C_p , L_s and R_s . However, there are large variations between manufacturers, indicating that other factors such as different choices of material and diameter of the cables affect their behavior.

The results of measuring the pickup impedance when connected to different cables are shown in Fig. 9. In Fig. 9 the impedances magnitude as a function of fre-

Table 2: Measured component values for each cable.

Cable	C_p pF	L_s μH	R_s Ω	C_p/l pF/m	L_s/l μH/m	R_s/l Ω/m
C0	85.9	4.1	0.12	286	13.67	0.41
C1	306	6.7	0.63	122	2.68	0.25
C2	423	5.7	0.66	141	1.90	0.22
C3	304	1.9	0.6	101	0.63	0.20
C4	225	13.5	1.97	38	2.25	0.33
C5	491	6.9	0.65	82	1.15	0.11
C6	747	3.4	0.74	125	0.57	0.12
C7	374	3.9	0.68	62	0.65	0.11
C8	599	3.4	0.76	100	0.57	0.13
C9	843	5.1	1.36	94	0.57	0.15

quency is shown for each cable measurement, where we can observe that the pickup resonance is affected by the cable. Table 3 further summarizes the results in Fig. 9 of the effect in the pickup resonance when a cable is connected to it, with the peak frequency and bandwidth in Fig. 9, for all the tested cables. From Table 3 it is possible to observe that when connected to the shortest cable C0, the pickup resonance is located at 4.93 kHz, whereas

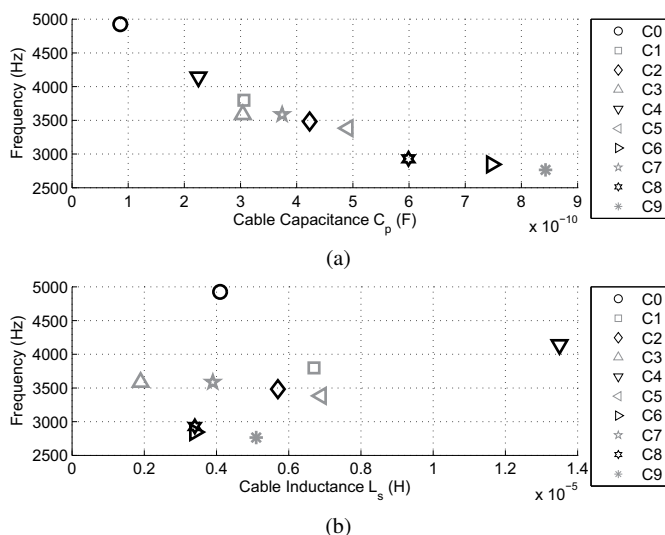

Figure 10: Resonance peak frequency for all cables as a function of (a) the parallel capacitance C_p and (b) the series inductance L_s .

when it is connected to the cable with largest capacitance C9 moves this resonance to 2.75 kHz (see Fig. 9 (a) and (b), respectively). Also, when comparing C9 with C4, which is the cable with largest resonant frequency that has a typical length for the first guitar cable, the change in the resonance frequency is of 1.4 kHz. Additionally, Table 3 shows how the Q value stays nearly constant.

In order to evaluate the effect of model component in Fig. 5 on the frequency of the pickup resonance, Fig. 10 shows plots of the measured components values of the cables as a function of the peak resonant frequency. In Fig. 10 (a) a clear trend on the pickup resonance frequency position can be observed when the cable capacitance is varied. In this case, the larger the cable capacitance is, the lower the frequency of the resonance peak will be. This means that the value of the cable capacitance is a good parameter to explain the variation in the pickup frequency response caused by the cable. In Fig. 10 (b) almost no correlation between the series inductance L_s can be noticed, where the same was observed for R_s . This indicates further that the cable capacitance is the most important parameter influencing the pickup frequency response.

Further evaluation of the effect of each cable element in

Table 3: Measured resonance frequency, bandwidth and quality factor of the cables connected to the pickup.

Cable	Resonant frequency	Bandwidth	Q
	Hz	Hz	
C0	4930	1830	2.7
C1	3800	1320	2.9
C2	3480	1300	2.7
C3	3590	1250	2.9
C4	4140	1540	2.7
C5	3380	1150	3
C6	2850	960	3
C7	3590	1250	2.9
C8	2930	990	3
C9	2760	940	3

the model is evaluated in Fig. 12. In this LTSpice [20] simulation a theoretical pickup model with inductance of 2 H, capacitance of 50 pF, series resistance of 10 k Ω , and parallel resistance of 1000 k Ω is used. The parameters of the pickup were chosen based on average values observed in measurements [10]. For comparison, the fre-

frequency response of the pickup without a cable attached is also presented in Fig. 12 with a solid black line. In the simulations a cable with $C_p = 400$ pF, $R_p = 900$ M Ω , $R_s = 0.8$ Ω , and $L_s = 2$ μ H is considered, which represents a typical cable based on the average measurement results of Table 2, and the individual elements C_p and L_s are varied individually.

From Fig. 12 (a) it is possible to notice that the cable capacitance is related to the frequency peak of the pickup resonance, which can be understood by the interaction of the output capacitance of the pickup, which is of the same order of magnitude as the capacitance of the cable. By observing Fig. 12 (b), it can be noticed that L_s has no impact on the frequency response of the pickup when the variation on these components are within the range observed in the measurements of Table 2. Also, simulations when varying R_s and R_p concluded in the same result. This further implies that when the effect of the cable on the guitar timbre is concerned, the cable can be represented as a simple capacitor connected in parallel to the guitar pickup as in Fig. 11.

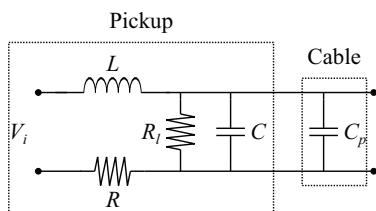

Figure 11: Equivalent circuit of a magnetic pickup when connected to a cable.

Additional measurements were made for approximating the frequency response of the cable itself. These measurements have shown a magnitude response gain within ± 0.001 dB. The results are however not very reliable since they are close to the noise floor of the measurement setup. Hence, the frequency response of these cables is relatively flat in the audio frequency range. This result indicates that, when considered alone, the linear filtering effect caused by these cables is negligible in the audio range.

Additionally, the effect of instrument cables can be considered in the chain from the electric guitar to the amplifier via several effect boxes. In that case, when noise

shielding is not considered, only the cable directly connected to the pickup changes significantly the guitar timbre. The cables connected between different effect boxes and the guitar amplifiers will have negligible effect if we consider that these boxes and amplifiers have proper buffering circuits, i.e. that they have high impedance input buffering stages that decouple the effect of subsequent circuits connected to them.

On the other hand, a different situation will occur when effect boxes are off and have bypass. In the case of ideal bypass, often called true bypass, the input jack of the effect box is directly connected to the output. Thus, when the effect box is in bypass mode, the input and output cables will be connected in series, resulting in a longer cable. By analyzing the equivalent circuit of the cable in Fig. 5, it is possible to notice that the capacitances will combine in parallel, resulting in a larger cable capacitance. Thus the resonant frequency of the pickup/cable system will be further decreased due to the capacitance of the cable connected to the output of the effect box. Additionally, if other types of bypass are used, which are not true bypass, the input impedance of the effect box is connected in parallel to the signal chain, resulting in additional modification of the signal.

5. CONCLUSIONS

This paper has presented the analysis of the effect of audio cables on the guitar timbre. The analysis has shown that these cables have a major effect on the frequency position of the pickup resonance, with variations as large as 1.4 kHz. It was shown that the variations on this resonance are caused by the cable capacitance. Additionally, the longest cable had the largest capacitance, which produced the lowest resonance frequency.

The analysis on the equivalent circuit used to model the cable has shown that many simplifications may be used. As a first step, the distributed impedance may be approximated by a single stage impedance without affecting the accuracy of the model. Additionally, the effect caused by cables may be approximated by a simple capacitance, since it is the only relevant parameter influencing the guitar timbre.

The results shown in this paper may be useful as guidelines for designing cables and should be considered when creating electric guitar synthesizers and physical models. As the tone control can only reduce the frequency band of the pickup output, the cable capacitance will

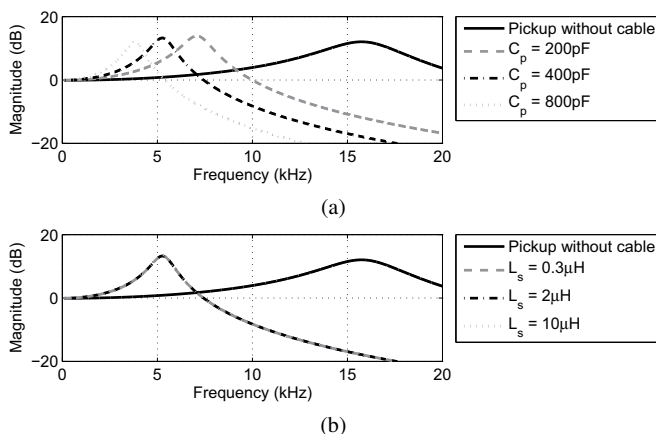

Figure 12: Simulation of the frequency response of a pickup without a cable (black solid lines) and connected with a cable when varying the cable parameters (a) C_p and (b) L_s . A theoretical pickup with average behaviour is considered in the simulation.

decrease the limit of the highest possible resonance frequency that can be achieved modifying the tone controls. Hence, when designing cables, a large capacitance cable will limit the control possibilities that the user will have with the guitar tone control. When realistic synthesis of electric guitar signals is considered, the models including magnetic pickups should consider that the pickup capacitance will be in reality larger than the one that is directly measured from the pickup, and the pickup resonance will occur at a lower frequency than the one expected with the pickup alone. In this case, a 200-400 pF capacitance connected to the output of the pickup can be assumed.

Finally, the effect of the cable on the pickup frequency response is not something that can easily be compensated with post-processing. This is due to the fact that, as the cable capacitance is included in the circuit, the cable interacts with the pickup circuit in a bidirectional manner, pushing the resonance to a lower frequency. Hence, proper compensation of that effect with an equalizer would only be possible when knowing the frequency response of the pickup with and without the cable. Furthermore, this type of solution would have an additional problem, due to the fact that this response is affected also by the tone control.

ACKNOWLEDGEMENTS

The authors are grateful to prof. Vesa Välimäki and Ju-

lian Parker for their comments on the manuscript and Dr. Miikka Tikander for his support and helpful comments. This work has been financed by the Academy of Finland (project no. 128689).

6. REFERENCES

- [1] F. E. Davis, “Effects of cable, loudspeaker, and amplifier interactions,” *Journal of Audio Engineering Society*, vol. 39, no. 6, pp. 461–468, June 1991.
- [2] R. Black, “Audio cable distortion is not a myth,” in *120th Audio Engineering Society Convention*, May 2006, preprint 6858. [Online]. Available: <http://www.aes.org/e-lib/browse.cfm?elib=13662>
- [3] J. C. G. Lesurf. (1999, September) Current dependent phase shifts in audio cables? (checked in May 20, 2011). [Online]. Available: http://www.st-andrews.ac.uk/~www_pa/Scots_Guide/audio/cables/shift/cp
- [4] C. Gough, “Electric guitar and violin,” in *The science of string instruments*, 1st ed., T. D. Rossing, Ed. Springer, 2010, ch. 22, pp. 393–415.
- [5] N. H. Fletcher and T. D. Rossing, *The Physics of Musical Instruments*. Springer-Verlag, 1998.

- [6] C. R. Sullivan, "Extending the Karplus-Strong algorithm to synthesize electric guitar timbres with distortion and feedback," *Computer Music Journal*, vol. 14, no. 3, pp. 26–37, 1990.
- [7] N. G. Horton and T. R. Moore, "Modeling the magnetic pickup of an electric guitar," *American Journal of Physics*, vol. 77, no. 2, pp. 144–150, February 2009.
- [8] G. Lemarquand and V. Lemarquand, "Calculation method of permanent-magnet pickups for electric guitars," *IEEE Transactions on Magnetics*, vol. 43, no. 9, pp. 3573–3578, September 2007.
- [9] M. Koch, *Building Electric Guitars*. Nürtingen, Germany: Koch Verlag, 2001.
- [10] T. Jungmann, "Theoretical and practical studies on the behavior of electric guitar pickups," Master's thesis, Department of Electrical Engineering, Acoustics Laboratory, Helsinki University of Technology, Espoo, Finland, 1994. [Online]. Available: http://www.acoustics.hut.fi/publications/files/theses/jungmann_mst.pdf
- [11] N. Lindroos, H. Penttinen, and V. Välimäki, "Parametric electric guitar synthesis," *Computer Music Journal*, 2011, (accepted for publication).
- [12] V. Välimäki, J. Pakarinen, C. Erkut, and M. Karjalainen, "Discrete-time modelling of musical instruments," *Reports on Progress in Physics*, vol. 69, no. 1, pp. 1–78, January 2006.
- [13] M. Karjalainen, T. Mäki-Patola, A. Kanerva, and A. Huovilainen, "Virtual air guitar," *Journal of Audio Engineering Society*, vol. 54, no. 10, pp. 964–980, October 2006.
- [14] F. T. Ulaby, *Electromagnetics for Engineers*. Upper Saddle River: Pearson Prentice Hall, 2005.
- [15] —, *Fundamentals of Applied Electromagnetics*, 5th ed. Upper Saddle River: Pearson Prentice Hall, 2007.
- [16] R. Boylestad, *Introductory Circuit Analysis*, 10th ed., 12th, Ed. Upper Saddle River, N.J.: Pearson - Prentice Hall, 2010.
- [17] Audio measurement and analysis software. (visited in May 25, 2011). [Online]. Available: <http://www.fesb.hr/~mateljan/arta/>
- [18] M. A. Schematics. (visited in May 11, 2011). [Online]. Available: <http://www.marshallschematics.com/>
- [19] R. Keen. (1998) The technology of the tube screamer. (visited in May 11, 2011). [Online]. Available: http://www.geofex.com/article_folders/tstech/tsxtech.htm
- [20] LTSpice IV. (visited in May 25, 2011). [Online]. Available: <http://www.linear.com/ltspace>